



Tallawarra Lands

# Tallawarra Lands Traffic Impact Assessment Addendum

Prepared by



February 2012

# Tallawarra Lands Traffic Impact Assessment Addendum



**GABITES PORTER**

*Traffic & Transportation  
Engineering & Planning*

---

Prepared by **David Hunter**  
Senior Transportation Engineer

Reviewed by

Approved by

Gabites Porter Consultants Ltd  
2 John Campbell Crescent  
P O BOX 42 047  
Christchurch  
New Zealand

Telephone: +64 3 366 9871

Date: 29<sup>th</sup> February 2012  
Reference: 4373  
Status: Final 1

# Tallawarra Lands Traffic Impact Assessment

## Addendum

### CONTENTS

<b>1. INTRODUCTION</b>	<b>1</b>
1.1 Background	1
1.2 Report Content	1
<b>2. ROADS AND MARITIME SERVICES COMMENTS</b>	<b>4</b>
2.1 Calderwood Development.	4
2.2 2036 Base Network Without the Tallawarra Development	4
2.3 Princes Hwy Lane Arrangement North of Tallawarra	5
2.4 Haywards Bay Link	5
2.5 Haywards Bay Interchange	6
2.6 F6 North Facing Ramps	7
<b>3. WOLLONGONG CITY COUNCIL COMMENTS</b>	<b>8</b>
3.1 Future Tallawarra Development Area	8
3.2 F6 North Facing Ramps	8
3.3 Closing Cormack Ave Access to Princes Hwy	8
<b>4. WIDER AREA ANALYSIS</b>	<b>9</b>
4.1 Land Use Activity Development Assumptions	9
4.2 Data Inputs – Warren Lee	9
4.3 Wider Network Testing	9
<b>5. MODEL RESULTS</b>	<b>11</b>
5.1 Test One – Base 2036	11
5.2 Test Two - The Warren Lee Master Plan	11
5.3 Test Three – Haywards Bay Link	13
5.4 Test Four – F6 Ramps at Tallawarra	14
5.5 Test Five – Three Laning of Princes at Tallawarra	14
5.6 Test Six – Haywards Bay Link via Macquarie PI	15
5.7 Test Seven – Yallah Rd Link	16
5.8 Test Eight – Haywards Bay Link and F6 Ramps at Tallawarra	16
5.9 SIDRA Intersection Analysis	17

### Appendix 1 – SIDRA Analyses for Critical Intersections

## LIST OF FIGURES

1.	Tallawarra Development Site Location	2
2.	Tallawarra Development Site Location	3
3.	2036 No Tallawarra Development Traffic Volume Plot AM Peak	18
4.	2036 No Tallawarra Development Traffic Volume Plot PM Peak	19
5.	2036 No Tallawarra Development Levels of Service Plot AM Peak	20
6.	2036 No Tallawarra Development Levels of Service Plot PM Peak	21
7.	2036 Base (No Hayward's Link) with 2 lane Princes Hwy Traffic Volume Plot AM Peak	22
8.	2036 Base 3 lane vs 2 lane Princes Hwy Change in Volume Plot AM Peak	23
9.	2036 Base (No Hayward's Link) with 2 lane Princes Hwy Traffic Volume Plot PM Peak	24
10.	2036 Base 3 lane vs 2 lane Princes Hwy Change in Volume Plot PM Peak	25
11.	2036 Base – 2 Lanes Princes Hwy Levels of Service Plot AM Peak	26
12.	2036 Base – 3 Lanes Princes Hwy Levels of Service Plot AM Peak	27
13.	2036 Base – 2 Lanes Princes Hwy Levels of Service Plot PM Peak	28
14.	2036 Base – 3 Lanes Princes Hwy Levels of Service Plot PM Peak	29
15.	2036 Without Hayward's Link Traffic Volume Plot AM Peak	30
16.	2036 With Hayward's Link Traffic Volume Plot AM Peak	31
17.	2036 Without Hayward's Link Traffic Volume Plot PM Peak	32
18.	2036 With Hayward's Link Traffic Volume Plot PM Peak	33
19.	2036 With Hayward's Link vs Without Hayward's Link Change in Volume Plot AM Peak	34
20.	2036 With Hayward's Link vs Without Hayward's Link Change in Volume Plot PM Peak	35
21.	2036 With Hayward's Link Levels of Service Plot AM Peak	36
22.	2036 With Hayward's Link Levels of Service Plot PM Peak	37
23.	2036 Select Link – Hayward's Off Ramp Traffic Volume Plot AM Peak	38
24.	2036 Select Link – Hayward's Off Ramp Traffic Volume Plot PM Peak	39
25.	F6 North Facing Ramps at Tallawarra	40
26.	2036 Base Without Hayward's Link Traffic Volume Plot AM Peak	41
27.	2036 Base Without Hayward's Link With Ramps Traffic Volume Plot AM Peak	42
28.	2036 Without Hayward's Link Traffic Volume Plot PM Peak	43
29.	2036 Base Without Hayward's Link With Ramps Traffic Volume Plot PM Peak	44
30.	2036 Base With vs Without Ramps Change in Volume Plot AM Peak	45
31.	2036 Base With vs Without Ramps Change in Volume Plot PM Peak	46
32.	Warren Lee Master Plan	47
33.	2036 With Tallawarra vs Without Tallawarra Change in Volume Plot AM Peak	48
34.	2036 With Tallawarra – No Hayward's Link Levels of Service Plot AM Peak	49
35.	2036 Internal Development – No Hayward's Link Traffic Volume Plot AM Peak	50
36.	2036 With Tallawarra vs Without Tallawarra Change in Volume Plot PM Peak	51
37.	2036 With Tallawarra – No Hayward's Link Levels of Service Plot PM Peak	52
38.	2036 Internal Development – No Hayward's Link Traffic Volume Plot PM Peak	53
39.	2036 Internal Development - With Hayward's Link Traffic Volume Plot AM Peak	54
40.	2036 Internal Development - With Hayward's Link Traffic Volume Plot PM Peak	55
41.	2036 With F6 Ramps - No Hayward's Link Levels of Service Plot AM Peak	56
42.	2036 With F6 Ramps - No Hayward's Link Levels of Service Plot PM Peak	57
43.	2036 Alternative Hayward's Bay Link Traffic Volume Plot AM Peak	58
44.	2036 Alternative Hayward's Bay Link Traffic Volume Plot PM Peak	59
45.	2036 Alternative Hayward's Bay Link Levels of Service Plot AM Peak	60
46.	2036 Alternative Hayward's Bay Link Levels of Service Plot PM Peak	61
47.	2036 Yallah Rd Link Traffic Volume Plot AM Peak	62
48.	2036 Yallah Rd Link Traffic Volume Plot PM Peak	63
49.	2036 Yallah Rd Link Levels of Service Plot AM Peak	64
50.	2036 Yallah Rd Link Levels of Service Plot PM Peak	65

51.	2036 No Cormack Ave Connection to Princes Highway	Traffic Volume Plot AM Peak	66
52.	2036 No Cormack Ave Connection to Princes Highway	Traffic Volume Plot PM Peak	67
53.	2036 No Cormack Ave Connection to Princes Highway	Levels of Service Plot AM Peak	68
54.	2036 No Cormack Ave Connection to Princes Highway	Levels of Service Plot PM Peak	69
55.	2036 F6 Ramps + Haywards Bay Link No Tallawarra	Traffic Volume Plot AM Peak	70
56.	2036 F6 Ramps + Haywards Bay Link With Tallawarra	Traffic Volume Plot AM Peak	71
57.	2036 F6 Ramps + Haywards Bay Link No Tallawarra	Traffic Volume Plot PM Peak	72
58.	2036 F6 Ramps + Haywards Bay Link With Tallawarra	Traffic Volume Plot PM Peak	73
59.	2036 F6 Ramps + Haywards Bay Link No Tallawarra	Levels of Service Plot AM Peak	74
60.	2036 F6 Ramps + Haywards Bay Link With Tallawarra	Levels of Service Plot AM Peak	75
61.	2036 F6 Ramps + Haywards Bay Link No Tallawarra	Levels of Service Plot PM Peak	76
62.	2036 F6 Ramps + Haywards Bay Link With Tallawarra	Levels of Service Plot PM Peak	77
63.	AM Peak – No F6 Ramps, No Hayward's Bay Link, without Tallawarra Development		78
64.	PM Peak – No F6 Ramps, No Hayward's Bay Link, without Tallawarra Development		79
65.	AM Peak – No F6 Ramps, No Hayward's Bay, with Tallawarra Development		80
66.	PM Peak – No F6 Ramps, No Hayward's Bay, with Tallawarra Development		81
67.	AM Peak – with F6 Ramps, with Hayward's Bay, without Tallawarra Development		82
68.	PM Peak – with F6 Ramps, with Hayward's Bay, without Tallawarra Development		83
69.	AM Peak – with F6 Ramps, with Hayward's Bay, with Tallawarra Development		84
70.	AM Peak – with F6 Ramps, with Hayward's Bay, with Tallawarra Development		85

# 1. INTRODUCTION

## 1.1 Background

The Tallawarra Lands development has been accepted by the Director General of Planning as a Major Project under Part 3A of the Environmental Planning and Assessment Act 1979. The Director General's Requirements (DGRs) for environmental assessment were issued on 28<sup>th</sup> September 2009.

Gabites Porter has been commissioned by TRUenergy to prepare the transportation and traffic components of the Environmental Assessment to meet the DGRs.

Part of those requirements involved the investigation of the effects of the development on the wider road network, with a second part investigating internal road and transport systems within Tallawarra.

The traffic and parking requirements of the DGRs (items 10 and 11) in summary are as follows

- Traffic Generation in accordance with the RTA's Guide to Traffic Generating Developments
- Road/intersection upgrades
- Access
- Loading dock(s)
- Car parking arrangements
- Impacts upon public transport (including school bus routes)
- Measures to promote public transport usage
- Measures to promote pedestrian and cycle linkages
- Staging and funding of road/intersection upgrades
- Adequacy of parking.

## 1.2 Report Content

The TruEnergy Tallawarra TIA report dated February 2011 looked at each of the above requirements in turn with a brief initial comment. It then proceeded to describe the technical analysis that had been carried out as part of the Tallawarra TIA.

This addendum report has been prepared as a result of additional comments provided by Roads and Maritime Services (RMS) and Wollongong City Council (WCC) regarding the contents of the original TIA. Each comment will be addressed individually.

The latest draft version of this report has been sent to Roads and Marine Services (RMS) for their consideration and response to changes that were made to the report as a result of discussions with them. At the time of finalising this report no official response from RMS has been received.

The location of the Tallawarra Development site is shown in **Figure 1**. The development plan used in this analysis is shown in **Figure 2**. As the design of the development is an on-going process, it is likely that small changes to the development plan as shown will occur. None of these changes are expected to be of major significance and are not expected to result in substantial changes to the trip rates and trip distribution used in this analysis.

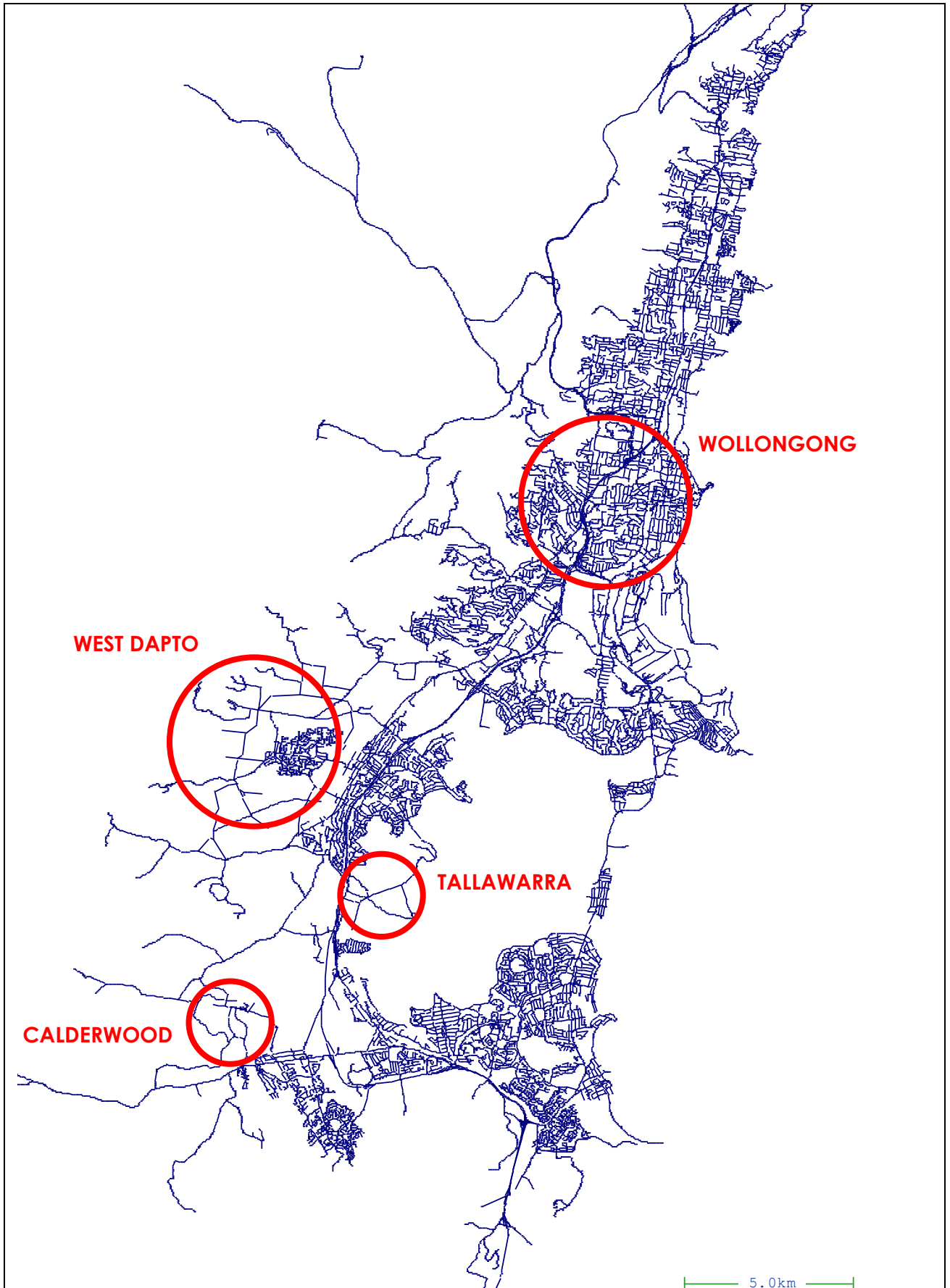

Tallawarra Transportation Model	<b>Tallawarra Development Site Location</b>	<b>Figure 1</b>
Gabites Porter Consultants		



Tallawarra Transportation Model  
 Gabites Porter Consultants

**Tallawarra Development Site Location**

**Figure 2**

## 2. ROADS AND MARITIME SERVICES COMMENTS

### 2.1 Calderwood Development

The original TIA analysis was undertaken using the then latest version of Wollongong and Shellharbour (WOLSH) model which did not include the proposed Calderwood development in its future land use scenarios. At that time, the Calderwood development was not considered an official part of the future development scenario as was therefore not included at the request of both the RMS and WCC.

The more recent Special Infrastructure Contributions (SIC) analysis had the Calderwood development included as an official element of the future land use. The TRACKS analysis undertaken for this addendum used, as its base, the SIC 2036 networks and associated agreed land use scenarios. 2036 was agreed by both RMS and WCC as the most suitable year to undertake this updated analysis. This allowed for all of Tallawarra to be developed, all of the likely SIC infrastructure to be included and allowed for large amounts of the West Dapto and Calderwood developments to be included.

The land use used in the 2036 Tallawarra modelling is summarised in **Table 1**.

Overall 2036 Land Use					Table 1
	Households	Retail	Community	Manufacturing	Total Jobs
West Dapto – Stage 1	3401	459	250	500	1424
West Dapto – Stage 2	2638	376	730	0	1245
West Dapto – Stage 3	2050	11	350	0	430
West Dapto – Stage 4	470	120	19	0	159
West Dapto – Stage 5	1200	124	68	163	502
Calderwood	4434	213	209	908	2454
Tallawarra	1210	113	181	2328**	3439**
Wollongong etc	118698	13327	28331	12344	108225
Total	134101	14743	30138	16243	117878

\*\*Note. These manufacturing employee figures have been increased so as to ensure that the trip rates from mixed industrial zones reflect a total trip rate of 14 trips/hr peak. This rate was calculated from a similar analysis produced by the Wingecarribee Shire Council for their proposed Enterprise Zone.

The list of future infrastructure included in the 2036 base model network is shown in Tables 1-5 of the Strategic Modelling Report for SIC, Executive Summary.

### 2.2 2036 Base Network Without the Tallawarra Development

In order to determine the impact of the Tallawarra development it was first necessary to model the agreed 2036 upgraded SIC model without the Tallawarra land use in place. This would show the traffic flows in the area as a result of general background growth in the Wollongong and Shellharbour areas and from the West Dapto and Calderwood developments.

**Figure 3** and **Figure 4** show the AM and Evening Peak flows in the Tallawarra area as a result of the above mentioned background and surrounding development growth. A more detailed set of modelled movement flows for the area without the Tallawarra Development in place are shown in **Figure 63** and **Figure 64**.

**Figure 5** and **Figure 6** show the Levels of Service (LOS) for both the road network and intersections in the area. The two areas of concern for the area are Princes Hwy from the F6 off ramp north to Huntley Rd in the Morning Peak and the Princes Hwy from the off ramp south to its merge with the F6 at the Yallah Interchange. These lengths of road are expected to operate at LOS E during these periods even without the Tallawarra development.

### **2.3 Princes Hwy Lane Arrangement North of Tallawarra**

The RMS have expressed concern that the SIC analysis for 2026-2036 included a section of the Princes Highway, from the F6 off-ramp to the Tallawarra main entrance, that had been upgraded to four lanes. This was an inadvertent coding error introduced as part of the coding for the Yallah Interchange infrastructure in the upgraded 2026 analysis.

The original Tallawarra TIA analysis did not include this four laning of the Princes Highway in this location. However, the RMS requested that this coding error was removed from all analysis undertaken for this addendum.

In order to show what impact the inclusion of these additional lanes may have on the Princes Hwy and whether that impact may result in the accelerated need for the north facing F6 ramps at Tallawarra, a series of models runs were undertaken with and without the additional Princes Hwy lanes. These runs were undertaken assuming the Tallawarra Development was in place. **Figure 7** to **Figure 10** show the base flow and the change in flows for the AM and Evening Peak as a result of the additional Princes Hwy capacity. Clearly, the overall impact on traffic flow of providing the additional lanes is minimal with less than 20 vph being affected. It is believed that the length of road affected by the additional lanes is not long enough to significantly affect trip distribution.

The additional lanes along this section of the Princes Hwy do provide additional local capacity and thereby reduce the Level of Service (LOS) in the immediate area. **Figure 11** to **Figure 14** show the LOS in the immediate area of the F6 off-ramp with and without the additional lane capacity. The existing 2 lane configuration is expected to operate at LOS F by 2036. However, the increase in capacity is expected to improve the LOS to C.

### **2.4 Haywards Bay Link**

As indicated in the RMS comments, a road linking the Tallawarra development and Haywards Bay was not included in the SIC analysis. An analysis of a Haywards Bay link, as part of the original TIA, showed that while the network has the capacity to absorb this volume of traffic, it may not be reasonable to place the expected amount of traffic on the Haywards residential area.

Further analysis was undertaken for this Addendum to assess the volumes using such a link and performance of the surrounding roads and intersections as a result of the link. **Figure 15** and **Figure 18** show details of the AM and Evening Peak flows in the

immediate Tallawarra area with and without the Haywards Bay link in operation. **Figure 19** and **Figure 20** show the change in local flow as a result of the link.

Clearly, the link allows for a convenient southern access point to and from the F6 and surrounding areas. It also allows the local southern residential areas to conveniently access the proposed Tallawarra retail areas. Without the link, F6 traffic from the south needs to proceed north past Tallawarra up to the Princes Hwy off-ramp and use the Princes Hwy southbound as primary access to Tallawarra. With the link in place, southern based traffic uses the Haywards Bay access directly. During the Morning and Evening Peaks, it is expected that some 800 and 650 vph respectively would want to use the Haywards Bay link. Whilst these levels of flow would not create congestion issues, they may well result in an unreasonable drop in amenity in the local Haywards Bay residential community.

**Figure 21** and **Figure 22** show the expected Morning and Evening Peak LOS conditions with the Haywards Bay link. The Morning peak is similar to the LOS position without the development. The Princes Hwy along the Tallawarra development maintains a LOS better than LOS D except for a short section north of the main entrance where it suffers LOS E. The expected flow at this point is 1370 vph which is only 35 vph into the LOS E category.

The Evening Peak LOS of the F6 and Princes Hwy is again generally expected to be similar to that calculated for the network without the Haywards Bay link. However, the reduced flow along the Princes Hwy is expected to improve the LOS in the southbound direction from LOS F without the link to LOS E with the link. The Princes Hwy merge delay at the Yallah Interchange is also expected to improve to better than LOS D with an average day of 24 seconds.

Due to the potential for a drop in local Haywards Bay residential amenity as a result of this link, two alternative southern connections to the Haywards Bay interchange were investigated. They were:

1. A two-way single carriageway road from the south of the Tallawarra development, over the railway line and onto Macquarie Pl.
2. A two-way single carriageway road from the south of the Tallawarra development, over the Princes Hwy and onto Yallah Rd south of the Yallah Rd bend.

These have been analysed using the full TRACKS model and are reported in more detail in **Section 5.6 and 5.7**.

## **2.5 Haywards Bay Interchange**

RMS detailed a concern that the lack of F6 north facing ramps at Tallawarra could contribute to a decrease in operational efficiency of the Haywards Bay Interchange as a result of vehicles using the interchange as a U Turn facility to access Tallawarra to and from the north. A select link analysis was undertaken using the Morning and Evening Peak base networks that did not include either the Haywards Bay link or the F6 north facing ramps.

**Figure 23** and **Figure 24** show the expected number of vehicles using the Haywards Bay Interchange southbound off ramp and their origins and destinations. This analysis

showed that there are expected to be no vehicles coming from the north on the F6 and using the Haywards Bay Interchange as a means to access Tallawarra. The analysis showed that the majority of the traffic using the Haywards Bay off ramp were accessing Haywards Bay and the Marshall Mount/Calderwood areas.

The analysis does show that some 55-65 vph could be expected to use the Haywards Bay Interchange from Tallawarra in the peak periods to get access to both Haywards Bay and the Marshall Mount/Calderwood areas. Should the Haywards Bay link be opened this flow would be expected to drop to zero.

## **2.6 F6 North Facing Ramps**

Both the RMS and WCC have expressed concern that the Tallawarra development proposal does not include the installation of north facing ramps on and off the F6 opposite the Tallawarra entrances. The previous TIA analysis showed that there was little demand for these ramps either with or without the Tallawarra development in place. As part of this updated analysis, the F6 north facing ramps, as shown in **Figure 25**, were modelled for the 2036 Morning and Evening Peaks with no Haywards Bay link in place.

**Figure 26** to **Figure 29** show the Morning and Evening Peak flows in the immediate area with and without the ramps. **Figure 30** and **Figure 31** detail the change in flow for each peak and therefore indicate flow increases or decreases can be expected to occur. As can be seen in these figures, the on and off ramps are only expected to be used by approximately 180 vph each during either of the peak periods. This does appear to result in a reduction in modelled flow along Cormack Ave during the peaks of approximately 100 vph in each direction.

## 3. WOLLONGONG CITY COUNCIL COMMENTS

### 3.1 Future Tallawarra Development Area

The original Tallawarra TIA did not include the potential trip generation as a result of a 40ha block of land between Duck Creek and the Power Station. As part of this addendum analysis the trips generated by this area of Mixed Industrial land was taken into account. To determine what level of generation would be expected from such a large-scale mixed use area, Gabites Porter used detailed generation calculations produced by the Wingecarribee Shire Council for their proposed large Enterprise Zone.

The Wingecarribee Shire calculations showed that during the peak period a total of 14 trips per occupied hectare could be expected. The calculations also assumed that such a mixed use development would have an expected site coverage ratio of 65%. Consequently, the 40ha of future Industrial land would be expected to generate and attract a total of 364 movements in the Evening Peak hour. To ensure that this occurred, the number of employees for the Industrial area was adjusted until the TRACKS model created the required 364 movements.

### 3.2 F6 North Facing Ramps

See **Section 2.6**. The analysis for the ramps showed that during the Morning Peak period less than 350 vph would be expected to use the F6 ramps from the Tallawarra area. The entire Tallawarra development generates 2428 trips during the Morning Peak which indicates less than 14.5% of the generated Tallawarra traffic has a use for the ramps.

### 3.3 Closing Cormack Ave Access to Princes Hwy

WCC have expressed concern regarding the impact on Cormack Ave residents that additional Tallawarra traffic may have when added to the existing through traffic. The Cormack Ave, Compton St and Emerson Rd route is apparently already known as a rat-run route and the possibility of that being exacerbated is a concern.

An investigation into closing the Cormack Ave connection with the Princes Hwy was undertaken. **Figure 51** and **Figure 52** show that during both the Morning and Evening peaks projected traffic along Cormack Ave would drop to levels below what would occur without the Tallawarra development. However, this closure of Cormack Ave would add approximately 100-130 vph to both the north and southbound flows along the Princes Hwy north of the F6 off ramp at Tallawarra.

It is clear from the **Figure 51** and **Figure 52** that a sizeable number of vehicles will use the internal Tallawarra roads as an alternative route to travel to the south from Cormack Ave. The model indicates that approximately 320 vph and 380 vph during the Morning and Evening peaks respectively will travel through Tallawarra to access the Princes Hwy. This is a significant drawback to this option.

**Figure 53** and **Figure 54** show the expected LOS for the Morning and Evening Peaks as a result of the Cormack Ave closure. During the Morning Peak, there is little difference compared to the base Morning Peak LOS as shown in **Figure 11**. The additional flow along the Princes Hwy, as a result of the closure, increases the length of road operating at LOS E. During the Evening Peak, the increased Princes Hwy flow increases the length of road operating at LOS E and F for the southbound direction.

## 4. WIDER AREA ANALYSIS

### 4.1 Land Use Activity Development Assumptions

The start point for the analysis was the Masterplan developed by Warren Lee. This plan, shown in **Figure 32**, comprises some 13 separate areas, including residential, office, retail, enterprise zone, and industrial land uses. In addition, there are areas separated out for environmental, or drainage reasons that will have little or no land use activity on them.

### 4.2 Data Inputs – Warren Lee

In total, this plan produced 1210 households, 10,200 m<sup>2</sup> of retail with 113 employees, 15,000 m<sup>2</sup> of business park with 300 employees, 11,100 m<sup>2</sup> of retirement living zone with 54 employees, 30,000 m<sup>2</sup> of enterprise zone with 600 employees, 216,000 m<sup>2</sup> of industrial with 2098 employees, primary school with 50 employees and 76,000 m<sup>2</sup> in the power station with 224 employees.

The expected trip rates for each of the land use types as well as their explanations are detailed in the original Tallawarra TIA Section 3.2. The rates adopted for the Tallawarra Development were as follows:

- Residential – 0.60 trips per HH based higher than average HH densities
- Retail – 4.6 trips per 100m<sup>2</sup> for mixture of retail uses and an average day
- Commercial – 1.5 trips per 100m<sup>2</sup> for reduced Tallawarra mode split
- Enterprise & Power Station – 1.0 trips per 100m<sup>2</sup>
- Industrial - RTA guide says that 68% of the employees are car drivers and that 55% of the commuter travel occurs in the peak hour. This formula has been used.

Applying the same assumptions as above, the expected Peak trip generation would be 2509 trips compared with 2477 trips generated by the model.

### 4.3 Wider Network Testing

The effects of the Tallawarra lands development was tested through the SIC model with the following assumptions.

The model was run using the 2036 land use as agreed by WCC and the RMS. This included growth in the various West Dapto Stages up to what was expected for 2036, but not the complete potential development. It included the level of Calderwood development expected by 2036 and all of the Tallawarra development.

The base network included those changes that have already been accepted by WCC and RMS as part of the SIC for what is expected to be necessary for 2036.

Eight separate test runs were undertaken for each of the Morning and Evening peak periods. The tests were:-

**Test One.** The 2036 base network and land use with no development in Tallawarra. This run determines the performance of the network and identifies deficiencies that will occur as a result of other developments.

**Test Two.** The land use activity and pattern under the Warren Lee Master Plan for Tallawarra is added with no Haywards Bay link. The comparison of this run against Test One shows the effects of the development.

**Test Three.** Test Two but with the road link to Hayward's Bay.

**Test Four.** Test Two but with the North Facing F6 Ramps at Tallawarra. This, when compared to test two, shows the changes in flows and network behaviour as a result of including the ramps.

**Test Five.** Test Two but with the Princes Hwy from the F6 off ramp to the Tallawarra main entrance three laned for with two lanes southbound.

**Test Six.** Test Two with an alternative road link to Hayward's Bay via Macquarie Pl.

**Test Seven.** Test Two with the road link to Yallah Rd.

**Test Eight.** The 2036 network with both the North Facing F6 Ramps and the Hayward's Bay Link.

The demands that the development will place on the road system was investigated at two levels. The first of these was the impact that the development would have on the wider Wollongong network, and in particular the Freeway, the Princes Highway and the nature of the principal access points servicing the development.

The second level deals with the roads within Tallawarra lands, and the need to develop an appropriate hierarchy of roads and intersections that would cater for the demands that will be placed on them. This second level required a model with considerably more detail in it than in the full model. Accordingly, a 'window' was cut from the full model in order to develop a 'sub-area' model for the site. The full model has 13 traffic zones for the Tallawarra while the sub-area model allowed for 80 zones – a level of detail not appropriate in the full model.

The full model enabled analysis of the wider area effects, and provided the traffic flows at the five access points to the development and origins and destinations at a broad level within the development.

Within the full model, a skeleton road network has been assumed for Tallawarra Lands. It includes the main spine road from the Princes Highway past the Power Station and up to Koonawarra, Single circulating lane roundabouts were initially assumed where the internal roads connect to the existing network in the west, but the testing showed that dual circulating roundabouts were required to connect with the Princes Highway.

The sub-area model then enabled a more detailed analysis of the internal roading and transport system to a more detailed level. Detailed SIDRA analysis of the major intersections in and around the Tallawarra development for with and without the Haywards Link was undertaken using flows taken from the detailed model. The results of the SIDRA analyses are shown in the Appendix. The internal roads have been assumed as two lane pending investigation of the detailed internal traffic flow. The proposed roundabouts along the Princes Hwy have been assumed to be dual circulating roundabouts in the SIDRA analyses.

## 5. MODEL RESULTS

### 5.1 Test One – Base 2036

**Figure 5** and **Figure 6** show the LOS which would exist in the Morning and Evening peak periods by 2036 without the Tallawarra development. Mid block LOS is represented by lines on the links, while the circles show LOS at intersections. The larger the circle, the higher the delay within a particular LOS band. A more detailed set of modelled movement flows for the area without the Tallawarra Development in place are shown in **Figure 63** and **Figure 64**.

As expected, the F6, north of Fowlers Road is overloaded in both the Morning and Evening peaks, even with an additional lane in each direction provided as part of the SIC. The intersection of Fowlers Road and the Princes Highway needs additional capacity.

Closer to the Tallawarra Lands site the Princes Highway southbound in the Evening peak are overloaded at some locations north of the intersection with the Tongarra Rd and along the Illawarra Hwy northbound in the Evening peak. There are a couple of minor intersections with high side road delays, but the major intersection of the Princes Highway with Lake Entrance Road is showing signs of stress.

The two areas of concern for the area are Princes Hwy from the F6 off ramp north to Huntley Rd in the Morning Peak and the Princes Hwy from the off ramp south to its merge with the F6 at the Yallah Interchange. These lengths of road are expected to operate at LOS E during these periods even without the Tallawarra development. The projected volumes during the Evening Peak along this part of the Princes Hwy are only 40 vph below LOS F.

### 5.2 Test Two - The Warren Lee Master Plan

#### *The wider network – Morning Peak*

**Figure 33** shows the change in traffic flow that occurs with the land use activity and layout assumed for the Warren Lee master plan, and without any connection to Haywards Bay. A more detailed set of Morning Peak modelled movement flows for the area with the Tallawarra Development in place are shown in **Figure 65**.

There are two changes to the base network that are required with this land use activity, and the removal of an access through to Haywards Bay. These include

- Two lane circulating roundabouts at each of the other two access points to the site off the Princes Highway
- A new roundabout at the northern access off Cormack Ave

**Figure 34** show the Morning Peak levels of Service with these improvements included. The LOS is very similar to the LOS on the Base network.

#### *Detailed Internal Traffic – Morning Peak*

**Figure 35** shows the internal traffic flows within the site. Single lane roundabouts have been assumed at the main intersections. There are no capacity issues with the largest

flow being almost 645 vph near the main commercial centre, and 331 vph southbound on the bridge over Duck Creek.

The majority of the Morning peak inbound traffic enters the site from the north from the Princes Highway. About half of this comes from the north and about half from the south via the northbound off ramp. In total, the inbound flow at the primary access is 645 vph – about one third of the southbound flow on the Princes Highway north of the access.

A further 305 vph enters the site from the southern Princes Hwy access, with about 202 vph entering from Cormack Avenue, and 195 vph from Gilba Road.

### **The Wider Network – Evening Peak**

**Figure 36** shows the change in traffic flow in the Evening peak hour. In general the flows during the Evening peak are higher than the Morning peak but the change in flows are generally less than the Morning peak. The conflicting demands of exiting traffic from Tallawarra to the west against those heading south on the Princes Hwy generally are expected to require the roundabouts to have two lane circulating capability. Flow along Cormack Ave is expected to increase by approximately 100 vph in each direction. A more detailed set of Evening Peak modelled movement flows for the area with the Tallawarra Development in place are shown in **Figure 66**.

**Figure 37** shows the Evening Peak Level of Service. The LOS pattern is reasonable similar to that which can be expected without Tallawarra. However, the additional generation of Tallawarra and its attractiveness for employment mean that most locations along the Princes Hwy in the immediate area of Tallawarra have decreased in LOS by a level. Those areas that were LOS E are now expected to be LOS F and some localised areas that were LOS D have decreased to LOS E. The single lane southbound merge from Princes Hwy onto the F6 is expected to increase in average delay from 24 seconds to 29 seconds.

### **Detailed Internal Traffic – Evening Peak**

Finally, **Figure 38** shows the internal flows, all generally less than the Morning peak, and there are no capacity issues. The largest flow is the 498 vph outbound to the Princes Highway on the central main entrance. A further 350 vph exit through the southern entrance. The Cormack Avenue entrance is expected to have 245 vph entering to gain access to the northern residential areas.

The modelled distribution of trips to and from the Tallawarra site indicates that approximately 40% of peak hour trips are travelling to south of the site. A select link analysis was undertaken to determine the number of modelled trips travelling south on the F6. This found that during the Morning Peak 994 trips out of a total of 2477 trips had an origin or destination south along the F6.

The original Tallawarra TIA indicated that this proportion was 50-60% for the preferred Warren Lee Masterplan as shown in **Figure 12** and **Figure 15**. This Addendum Report used updated land use data provided by the SIC and therefore a different trip distribution can be reasonably expected.

## 5.3 Test Three – Haywards Bay Link

### The wider network – Morning Peak

**Figure 19** shows the change in traffic flow that occurs as a result of creating a connection to Haywards Bay from the south of the Tallawarra development. The opening of an additional connection to the south, off the Haywards Bay interchange, means that traffic from the south no longer has to travel the site via the F6 off ramp at the Princes Hwy. This removes approximately 540 vph northbound along the F6, on the F6 off ramp and southbound along the Princes Hwy into Tallawarra.

Flow southbound along the Princes Hwy would decrease to a volume similar to that which would occur without the Tallawarra development.

If the Haywards Bay link were to be included, those 540 vph would use the Haywards Bay interchange and travel through the residential area along Haywards Bay Drive.

**Figure 21** shows the Morning Peak Level of Service. The Morning peak it is similar to the LOS position without the development. The Princes Hwy along the Tallawarra development maintains a LOS better than LOS D except for a short section north of the main entrance where it suffers LOS E. The expected flow at this point is 1370 vph which is only 35 vph into the LOS E category.

### Detailed Internal Traffic – Morning Peak

**Figure 39** shows the internal traffic flows within the site with the Haywards Bay link open using the more detailed sub-area model. The busiest section of road in the development is expected to be along the main entrance road to the east of the main north-south road with some 500 vph eastbound. The distribution of flow amongst the three northern entrances is relatively even with the Hayward Bay link access being busier than any other entrance.

### The Wider Network – Evening Peak

**Figure 20** shows the change in traffic flow in the Evening peak hour. The impact of adding the Haywards Bay link during the Evening Peak is not as large as during the Morning Peak. Flow from the Tallawarra development already has two readily accessible exits for southbound traffic. Consequently the southbound traffic using the link is expected to be approximately 370 vph. An additional 260 vph are expected to enter the site from the south.

Flow on the F6 is expected to drop by 150-250 vph depending on the section of F6 considered.

**Figure 22** shows the Evening Peak Level of Service. The LOS of the F6 and Princes Hwy in the area is generally expected to be similar to that calculated for the network without the Haywards Bay link. The reduced flow along the Princes Hwy is expected to improve the LOS in southbound locations where LOS F is to be expected, to E. The Princes Hwy merge delay at the Yallah Interchange is expected to improve to better than LOS D with an average delay of 24 seconds.

### **Detailed Internal Traffic – Evening Peak**

**Figure 40** shows the internal traffic flows within the site. All are generally less than the Morning peak, and there are no capacity issues. The largest flow is the 435 vph outbound to the Princes Highway on the central main entrance. The southern entrance is not expected to have any significant flow exiting the development onto the Princes Hwy. Most traffic from the Tallawarra southern residential and business districts are expected to use the new Link road to travel south. The Cormack Avenue entrance is expected to have 199 vph entering to gain access to the northern residential areas.

## **5.4 Test Four – F6 Ramps at Tallawarra**

### **The wider network – Morning Peak**

**Figure 30** shows the change in traffic flow that occurs as a result of constructing north facing ramps from the Princes Hwy onto the F6 at Tallawarra. As can be seen the on and off ramps are only expected to be used by approximately 180 vph each during the Morning Peak. This results in a reduction in modelled flow along Cormack Ave of approximately 100 vph northbound and 120 vph southbound. However, it only creates a 60 vph reduction in total flow along the Princes Hwy north of the proposed ramps.

**Figure 41** shows the Morning Peak Level of Service. When compared to the LOS plot of the development without the ramps, **Figure 11**, there is little discernible difference except for the decrease to LOS D along the development main entrance road.

### **The Wider Network – Evening Peak**

**Figure 31** shows the change in traffic flow in the Evening peak hour as a result of the construction of the north facing ramps. As with the Morning Peak, the on and off ramps are only expected to be used by approximately 180 vph each during the Evening Peak. This results in a reduction in modelled flow along Cormack Ave of approximately 50 vph northbound and 140 vph southbound. The Princes Hwy volume, north of the proposed ramps, would be expected to reduce by 120 vph.

**Figure 42** shows the Evening Peak Level of Service. As with the Morning peak, it is very similar to the position without the ramps, except that the northbound direction on the Princes Hwy improves to LOS D north of the ramps.

## **5.5 Test Five – Three Laning of Princes at Tallawarra**

### **The wider network – Morning Peak**

**Figure 8** shows the change in traffic flow that is expected to occur as a result of three laning the Princes Hwy from the existing F6 off ramp south to the Tallawarra entrances with two lanes being created in the southbound direction. Clearly the short length of additional lanes makes very little difference to the traffic flow expected in the area. The change in travel time along the short 700m length of highway, as a result of the increased capacity, appears insufficient to encourage any large scale flow redistribution.

However, the primary reason for the additional lanes was to improve the LOS of the Princes Hwy as it had reduced to LOS F with as a result of the Tallawarra development.

**Figure 12** shows the Morning Peak Level of Service as a result of the four laning. When compared to **Figure 11** which shows the LOS with the existing lane configuration, the LOS F sections of the Princes Hwy have improved to better than LOS D. No other change is LOS is apparent. This is better than the situation would be without the Tallawarra development.

#### **The Wider Network – Evening Peak**

**Figure 10** shows the change in traffic flow in the Evening peak hour. Similarly to the Morning peak, there is little change in traffic flow expected as a result of the additional lane capacity.

**Figure 14** shows the Evening Peak Level of Service. As with the Morning peak, the LOS F sections of the Princes Hwy have improved to better than LOS D. No other change is LOS is apparent. This is better than the situation would be without the Tallawarra development.

### **5.6 Test Six – Haywards Bay Link via Macquarie PI**

#### **The wider network – Morning Peak**

**Figure 43** shows the Haywards Bay link via Macquarie PI attracts slightly more traffic than the original Haywards Bay link as shown in **Figure 16**. It however avoids adding traffic to the residential roads of Haywards Bay by utilising the commercially oriented Macquarie PI. Initial TRACKS analysis of the three main Haywards Bay Interchange intersections show that the intersections operate at the same levels as the original Haywards Bay link analysis in **Section 5.3**.

**Figure 45** shows the Morning Peak Level of Service. The Morning Peak is identical to that shown in **Figure 21** and therefore this alignment shows no performance difference to the original link road alignment.

#### **The Wider Network – Evening Peak**

**Figure 44** shows the Evening Peak volume using the alternative link. When compared to the original Evening Peak Haywards Bay link flow in **Figure 18**. It shows that the alternative link is again slightly more attractive than the original route. Again, initial TRACKS analysis of the three main Haywards Bay Interchange intersections, during the Evening Peak, show that the intersections operate at the same levels as the original Haywards Bay link analysis in **Section 5.3**.

**Figure 46** shows the Evening Peak Level of Service. The Morning Peak is identical to that shown in **Figure 22** and therefore this alignment shows no performance difference to the original link road alignment.

## 5.7 Test Seven – Yallah Rd Link

### The wider network – Morning Peak

This southern link option connects the Tallawarra development with Yallah Rd via a link over the Princes Hwy. At this preliminary stage it has been assumed that a roundabout will be used at the intersection of the link and Yallah Rd.

**Figure 47** shows the Yallah Rd link attracts approximately the same traffic as the original Haywards Bay link as shown in **Figure 16**. It avoids adding traffic to the three main Haywards Bay Interchange intersections but does however increase the number of vehicles crossing the Yallah Interchange northbound F6 on ramp flow. It is possible that this alignment could be altered to only create a one-way northbound connection leaving southbound traffic to use the other Tallawarra exit roads. This would eliminate any additional congestion or conflict at the Yallah on ramp intersection.

**Figure 49** shows the Morning Peak Level of Service. The Morning Peak is identical to that shown in **Figure 21** and therefore this alignment shows no performance difference to the original link road alignment.

### The Wider Network – Evening Peak

**Figure 49** shows the Evening Peak volume using the Yallah link. When compared to the original Evening Peak Haywards Bay link flow in **Figure 18** it is clear that this alternative link is slightly less attractive for southbound vehicles. This is presumably due to the longer southbound travel distance of this alignment compared to the original more direct route.

**Figure 50** shows the Evening Peak Level of Service. The Evening Peak is identical to that shown in **Figure 22**.

## 5.8 Test Eight – Haywards Bay Link and F6 Ramps at Tallawarra

### The wider network – Morning Peak

This option was requested by the RMS to determine the overall effect of having both the F6 Ramps at Tallawarra and a Hayward's Bay Link in place. It was hoped that the combination would reduce the incidence of unnecessary local movements on the F6 and Princes Hwy. This network option was analysed both with and without the Tallawarra Development in place.

**Figure 55** shows the Morning Peak flows around the Tallawarra Development that are expected to exist with the F6 Ramps in place but without any Tallawarra Development flow contributing to congestion. When compared to **Figure 56**, which shows Morning Peak flow with Tallawarra in place, there is clearly little difference in flows along the F6 and Princes Hwy. A more detailed set of Morning Peak modelled movement flows for the area both with and without the Tallawarra Development in place are shown in **Figure 67** and **Figure 68**.

The North Facing F6 Ramps at Tallawarra are not expected to carry significant flows with or without the Tallawarra Development. As shown in Test 3, the Hayward's Bay Link

is expected to divert approximately 700vph of Tallawarra's Morning Peak flow away from using the F6 and Princes Hwy in the immediate area of Tallawarra.

**Figure 59** and **Figure 60** show the Morning Peak Level of Service both with and without the Tallawarra Development. There is little overall difference in Level of Service. However, the presence of the Tallawarra Development does decrease the Level of Service on The Princes Hwy as a result of flow from the south accessing the northern parts of the Tallawarra Development.

### **The Wider Network – Evening Peak**

**Figure 57** shows the Evening Peak flows around the Tallawarra Development that are expected to exist with the F6 Ramps in place but without any Tallawarra Development flow contributing to congestion. When compared to **Figure 58**, which shows Evening Peak flow with Tallawarra in place, there is again little difference in flows along the F6 and Princes Hwy. A more detailed set of Evening Peak modelled movement flows for the area both with and without the Tallawarra Development in place are shown in **Figure 69** and **Figure 70**.

The North Facing F6 Ramps at Tallawarra are not expected to carry significant flows with or without the Tallawarra Development. As shown in Test 3, the Hayward's Bay Link is expected to divert approximately 500vph of Tallawarra's Evening Peak flow away from using the F6 and Princes Hwy in the immediate area of Tallawarra.

**Figure 61** and **Figure 62** show the Evening Peak Level of Service both with and without the Tallawarra Development. Again there is little overall difference in Level of Service. However, the presence of the Tallawarra Development does decrease the Level of Service on the F6, south of Fowlers Rd, as a result of flow from the south accessing the northern parts of the Tallawarra Development. There appears to be little difference in Level of Service as a result of the F6 Ramps.

## **5.9 SIDRA Intersection Analysis**

Detailed SIDRA analysis of the major internal Tallawarra intersections and external key locations have been undertaken. The results of those analyses are attached in the Appendix and comprise the SIDRA intersection performance summary sheet and plot of movement LOS for the following intersections:

1. F6 off ramp / Princes Hwy roundabout
2. Princes Hwy / Cormack Ave roundabout
3. Princes Hwy / Tallawarra Main Entrance roundabout
4. Princes Hwy / Tallawarra Southern Entrance roundabout
5. F6 off ramp / Haywards Bay Dr
6. Haywards Bay Dr / Yallah Rd on ramp
7. Internal Illawarra Main Entrance Dr / Main North-South Dr roundabout
8. Internal Illawarra Main Entrance Dr / Duck Creek Corridor Rd roundabout
9. Internal Illawarra Southern Entrance Dr / Main North-South Dr roundabout



Tallawarra Transportation Model	<b>2036 No Tallawarra Development Traffic Volume Plot AM Peak</b>	<b>Figure 3</b>
Gabites Porter Consultants		



Tallawarra Transportation Model	<b>2036 No Tallawarra Development Traffic Volume Plot PM Peak</b>	<b>Figure 4</b>
Gabites Porter Consultants		

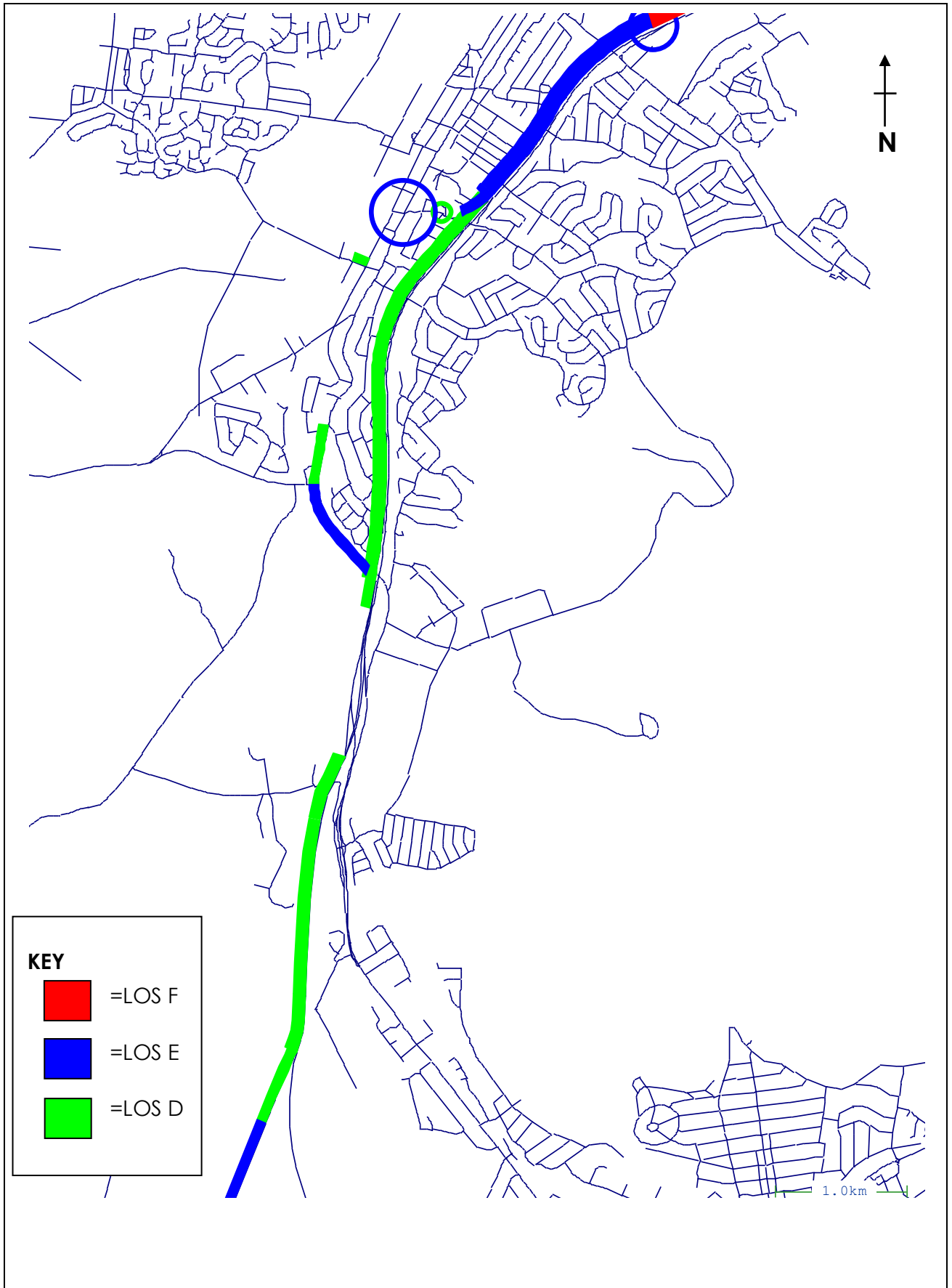

Tallawarra Transportation Model	<b>2036 No Tallawarra Development Levels of Service Plot AM Peak</b>	<b>Figure 5</b>
Gabites Porter Consultants		

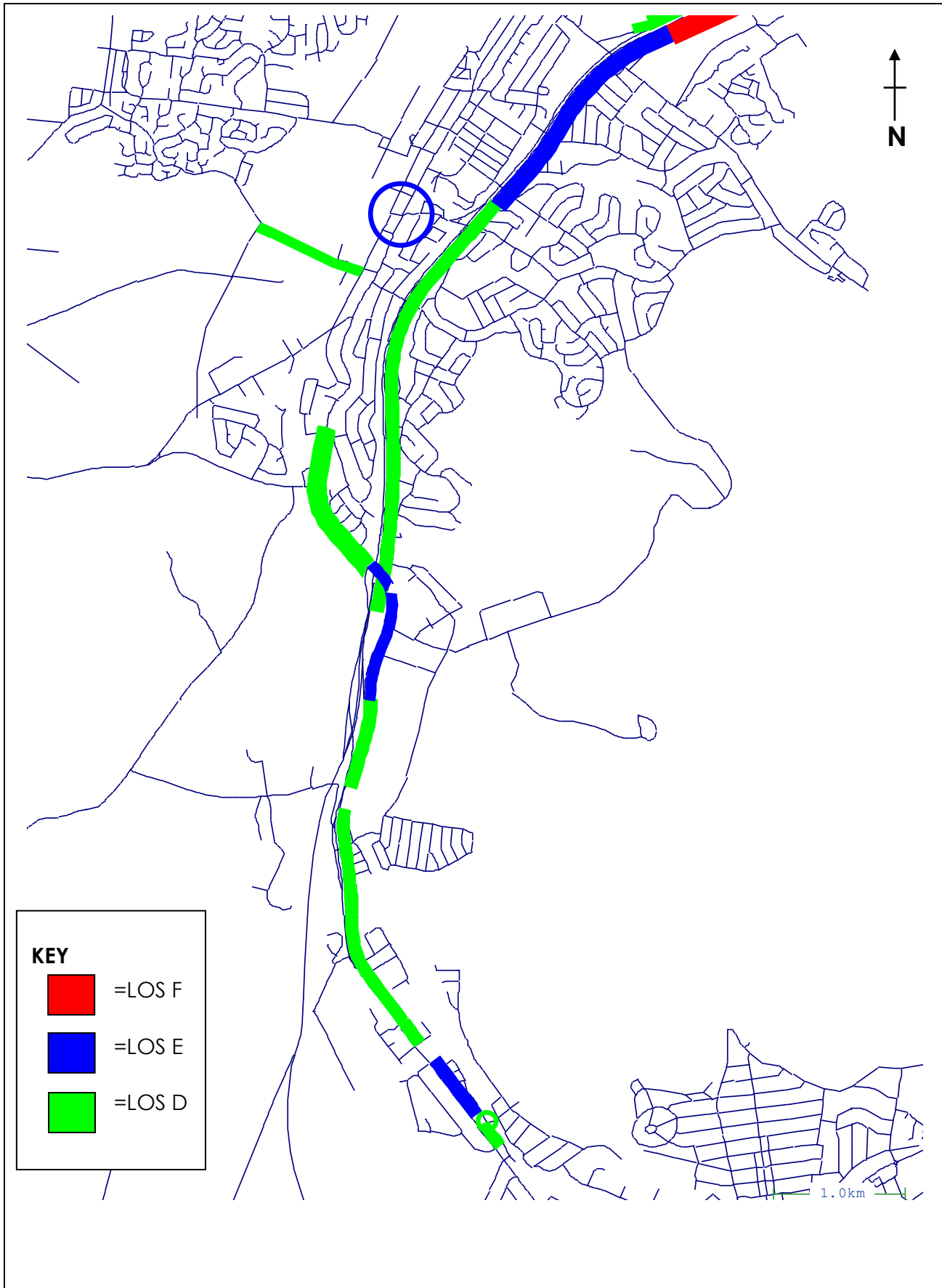

Tallawarra Transportation Model	<b>2036 No Tallawarra Development Levels of Service Plot PM Peak</b>	<b>Figure 6</b>
Gabites Porter Consultants		



Tallawarra Transportation Model	<b>2036 Base (No Hayward's Link) with 2 lane Princes Hwy Traffic Volume Plot AM Peak</b>	<b>Figure 7</b>
Gabites Porter Consultants		

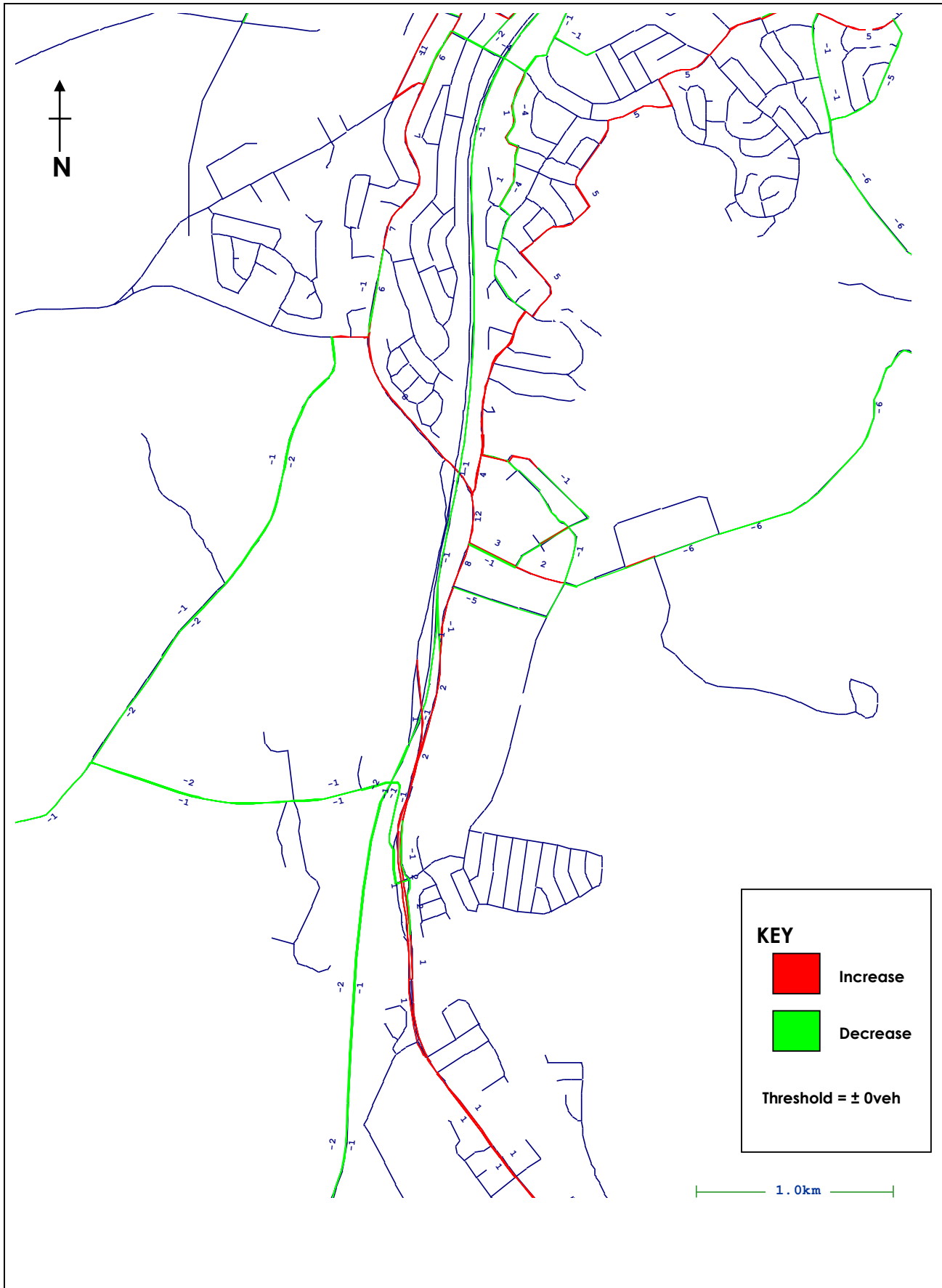

Tallawarra Transportation Model	<b>2036 Base 3 lane vs 2 lane Princes Hwy Change in Volume Plot AM Peak</b>	<b>Figure 8</b>
Gabites Porter Consultants		



Tallawarra Transportation Model	<b>2036 Base (No Hayward's Link) with 2 lane Princes Hwy Traffic Volume Plot PM Peak</b>	<b>Figure 9</b>
Gabites Porter Consultants		

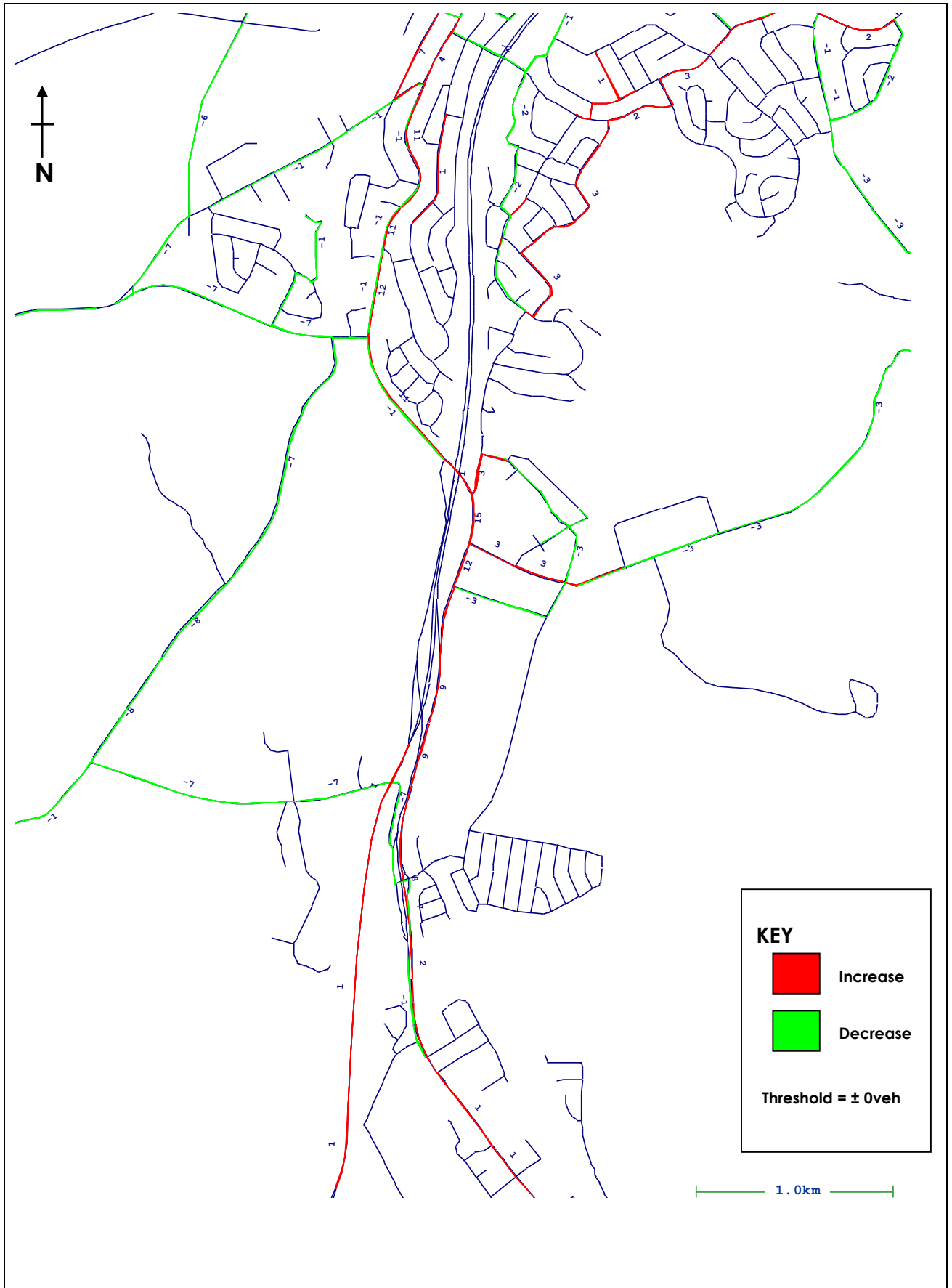

Tallawarra Transportation Model	<b>2036 Base 3 lane vs 2 lane Princes Hwy Change in Volume Plot PM Peak</b>	<b>Figure 10</b>
Gabites Porter Consultants		

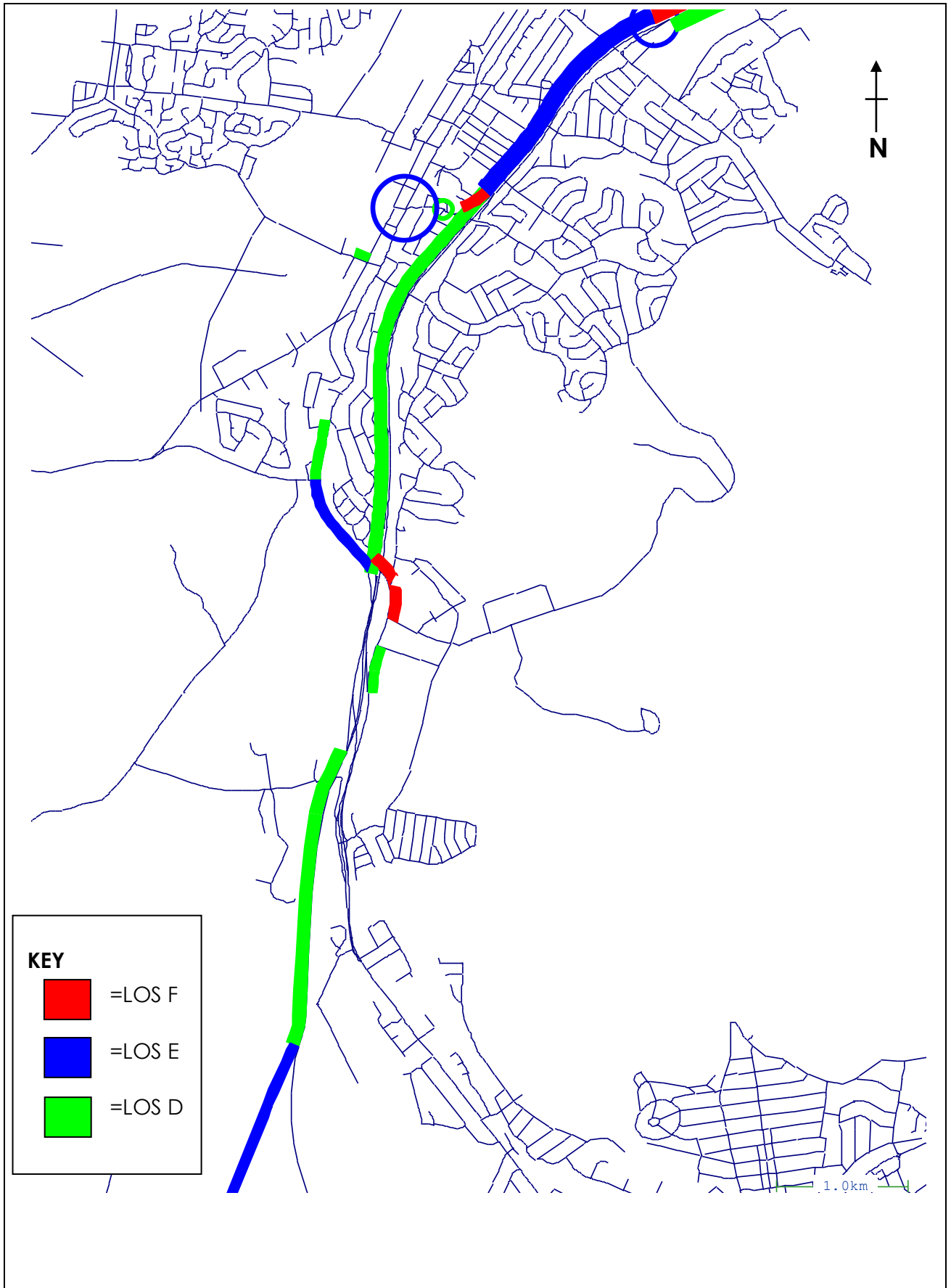

Tallawarra Transportation Model	<b>2036 Base – 2 Lanes Princes Hwy Levels of Service Plot AM Peak</b>	<b>Figure 11</b>
Gabites Porter Consultants		

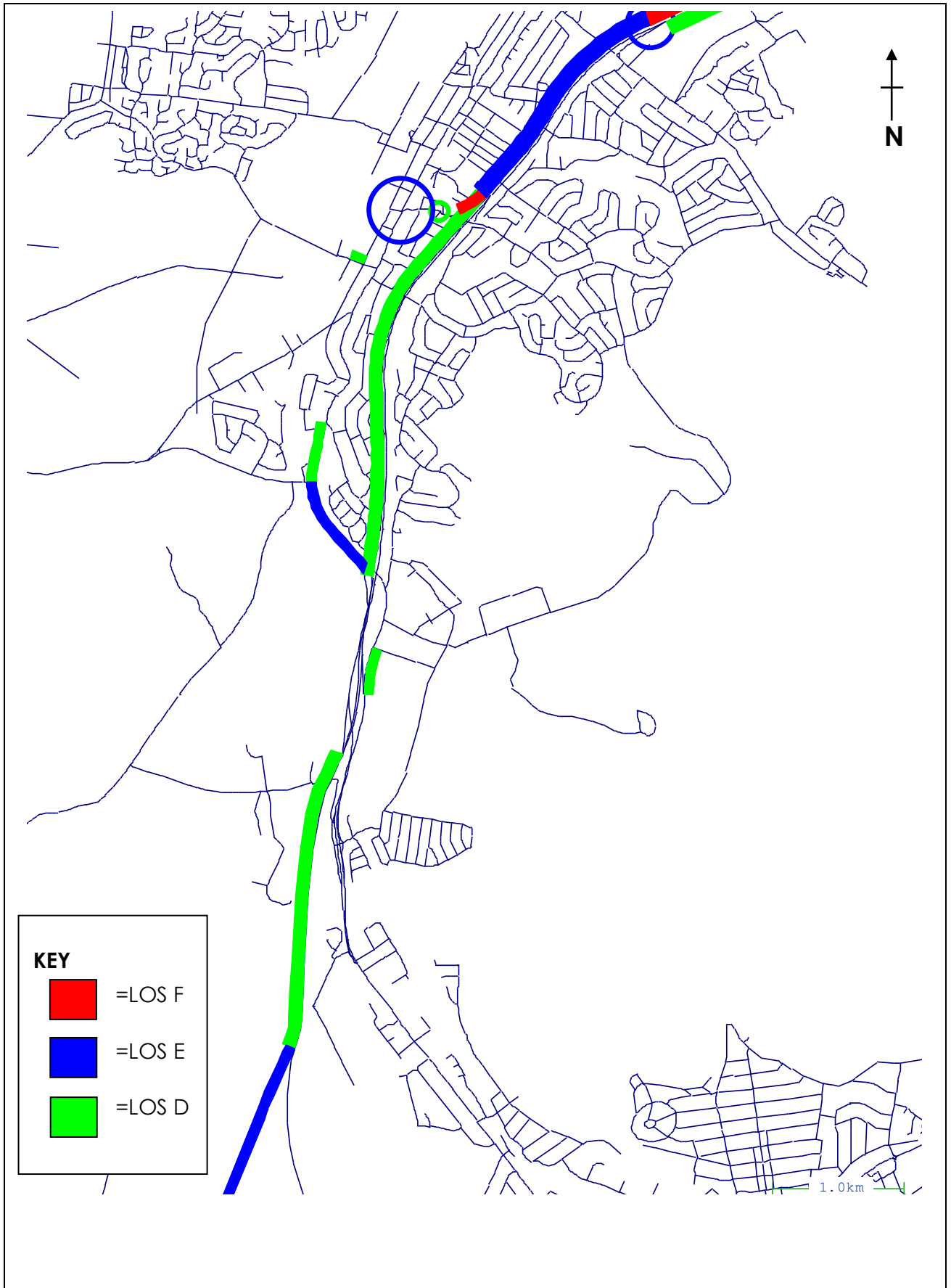

Tallawarra Transportation Model	<b>2036 Base – 3 Lanes Princes Hwy Levels of Service Plot AM Peak</b>	<b>Figure 12</b>
Gabites Porter Consultants		

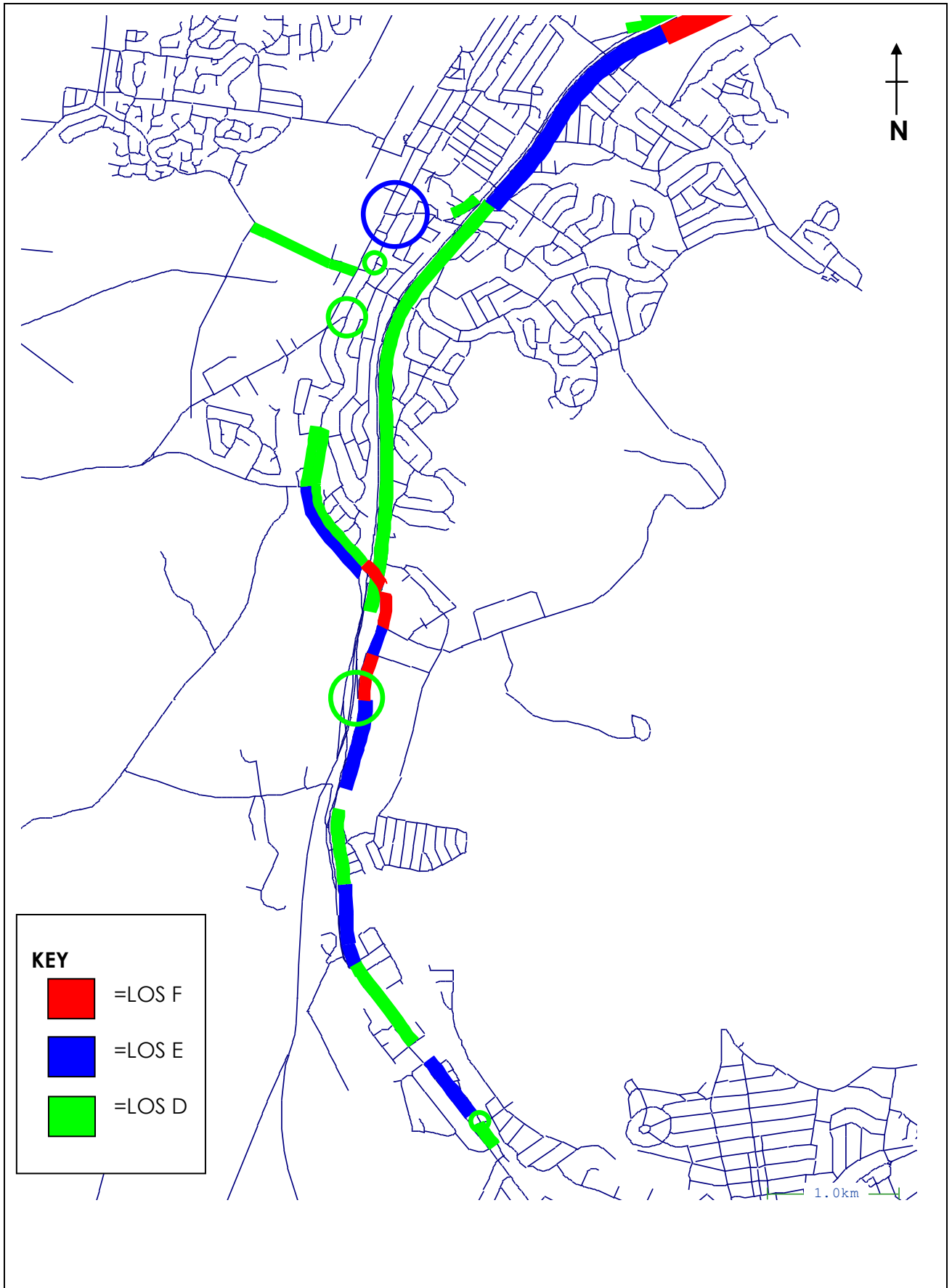

Tallawarra Transportation Model	<b>2036 Base – 2 Lanes Princes Hwy Levels of Service Plot PM Peak</b>	<b>Figure 13</b>
Gabites Porter Consultants		

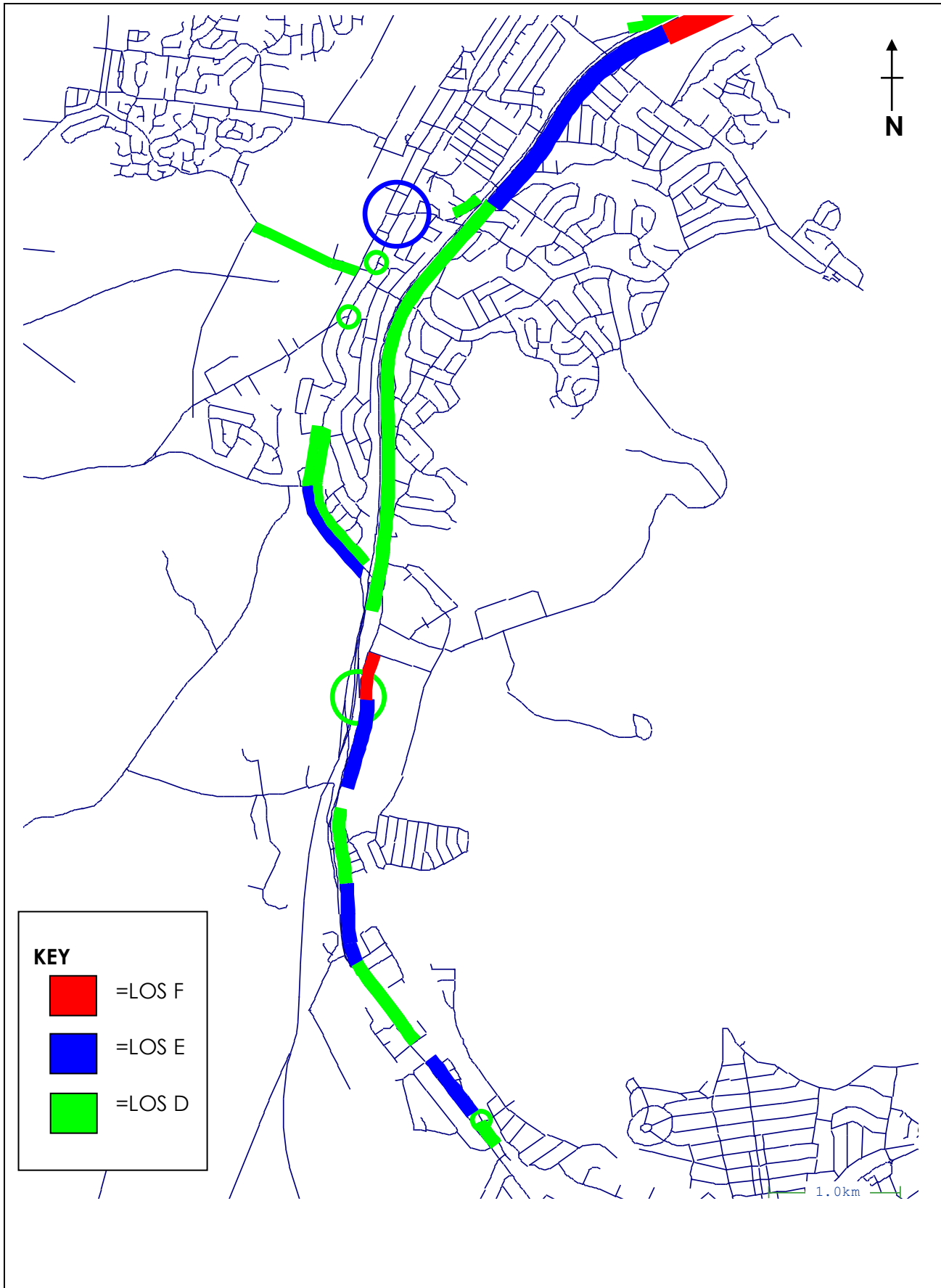

Tallawarra Transportation Model	<b>2036 Base – 3 Lanes Princes Hwy Levels of Service Plot PM Peak</b>	<b>Figure 14</b>
Gabites Porter Consultants		



Tallawarra Transportation Model	<b>2036 Without Hayward's Link Traffic Volume Plot AM Peak</b>	<b>Figure 15</b>
Gabites Porter Consultants		

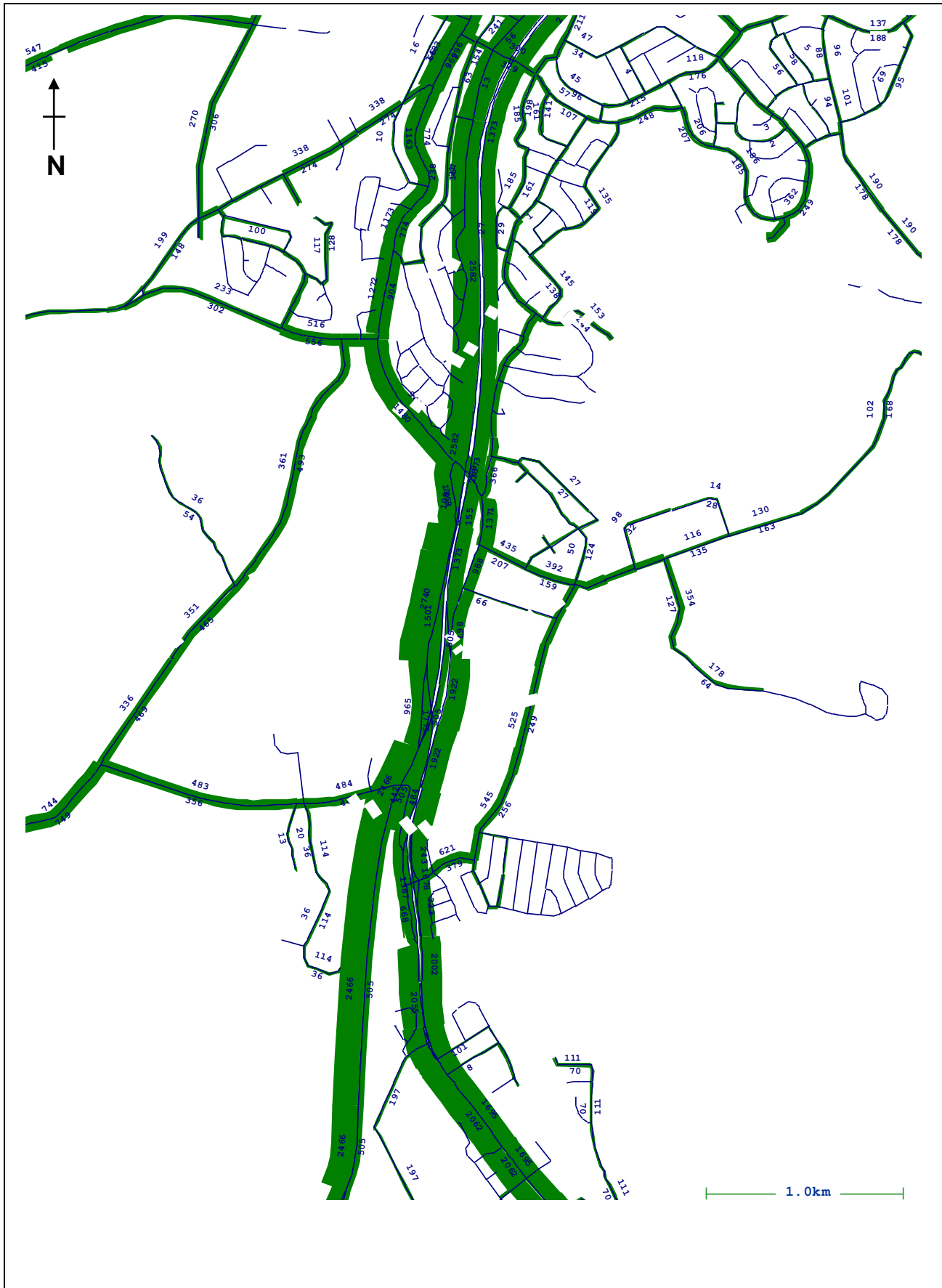

Tallawarra Transportation Model	<b>2036 With Hayward's Link Traffic Volume Plot AM Peak</b>	<b>Figure 16</b>
Gabites Porter Consultants		



Tallawarra Transportation Model	<b>2036 Without Hayward's Link Traffic Volume Plot PM Peak</b>	<b>Figure 17</b>
Gabites Porter Consultants		



Tallawarra Transportation Model	<b>2036 With Hayward's Link Traffic Volume Plot PM Peak</b>	<b>Figure 18</b>
Gabites Porter Consultants		

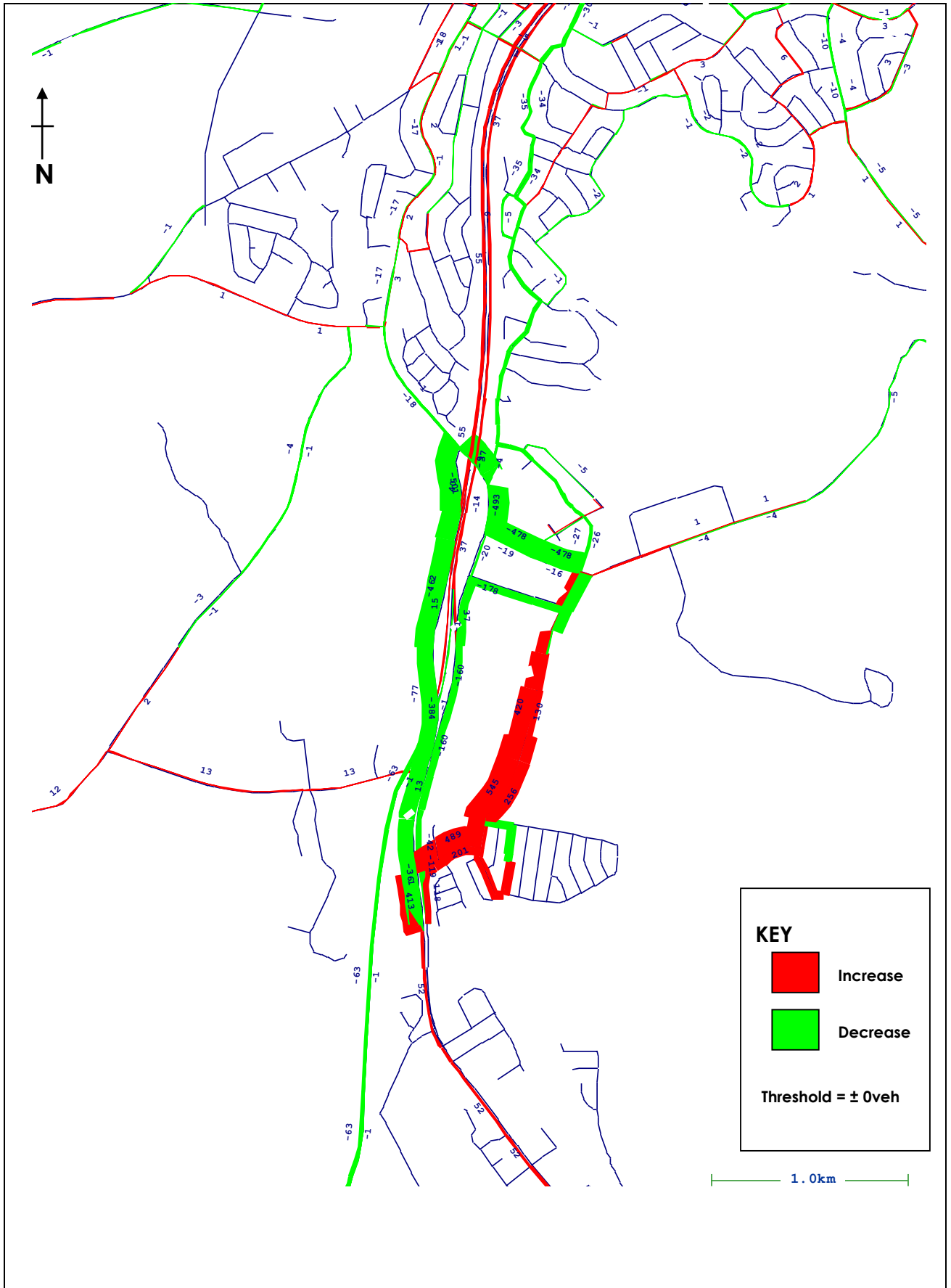

Tallawarra Transportation Model	<b>2036 With Hayward's Link vs Without Hayward's Link</b> <b>Change in Volume Plot</b> <b>AM Peak</b>	<b>Figure 19</b>
Gabites Porter Consultants		

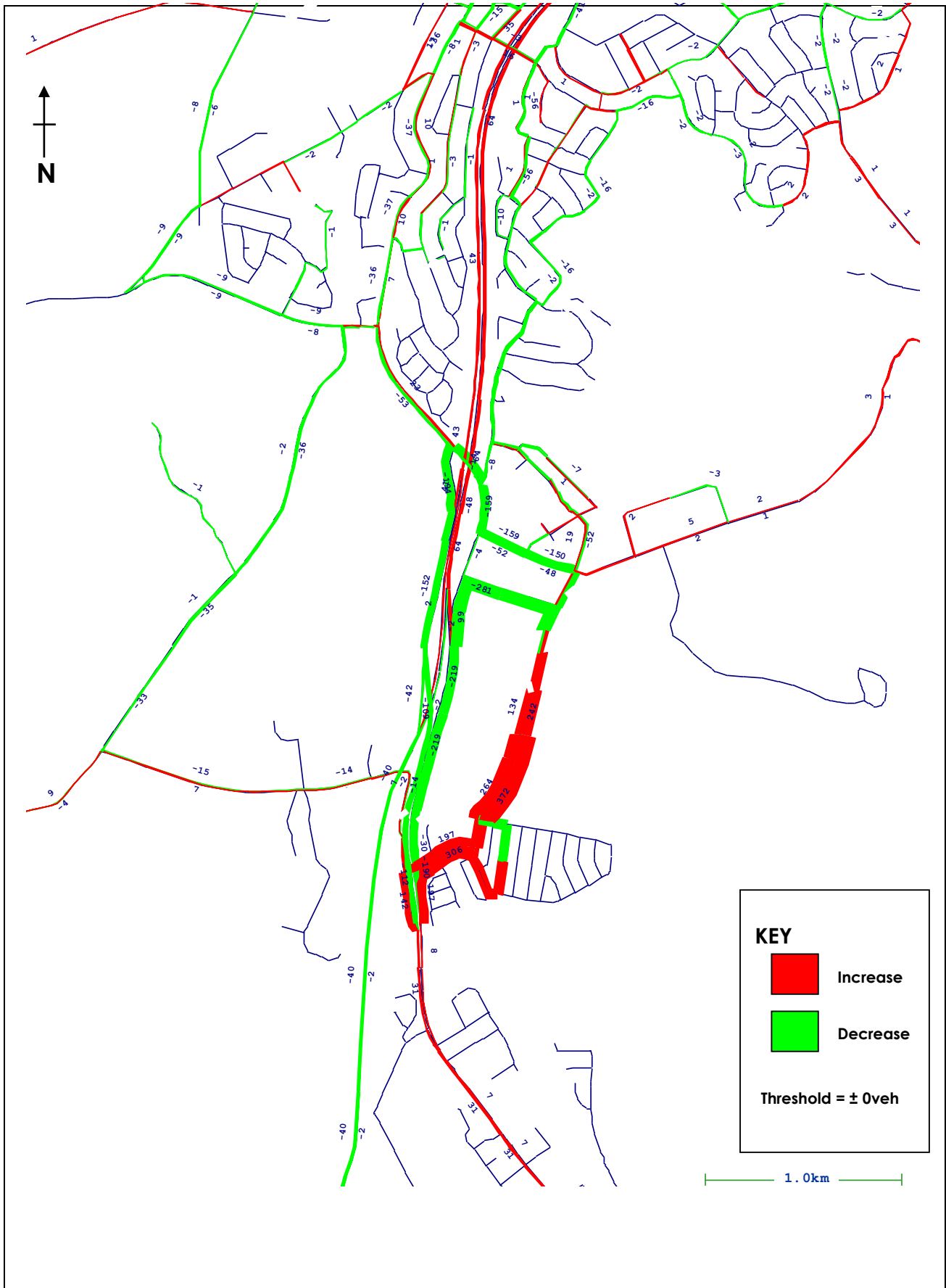

Tallawarra Transportation Model	<b>2036 With Hayward's Link vs Without Hayward's Link</b> <b>Change in Volume Plot</b> <b>PM Peak</b>	<b>Figure 20</b>
Gabites Porter Consultants		

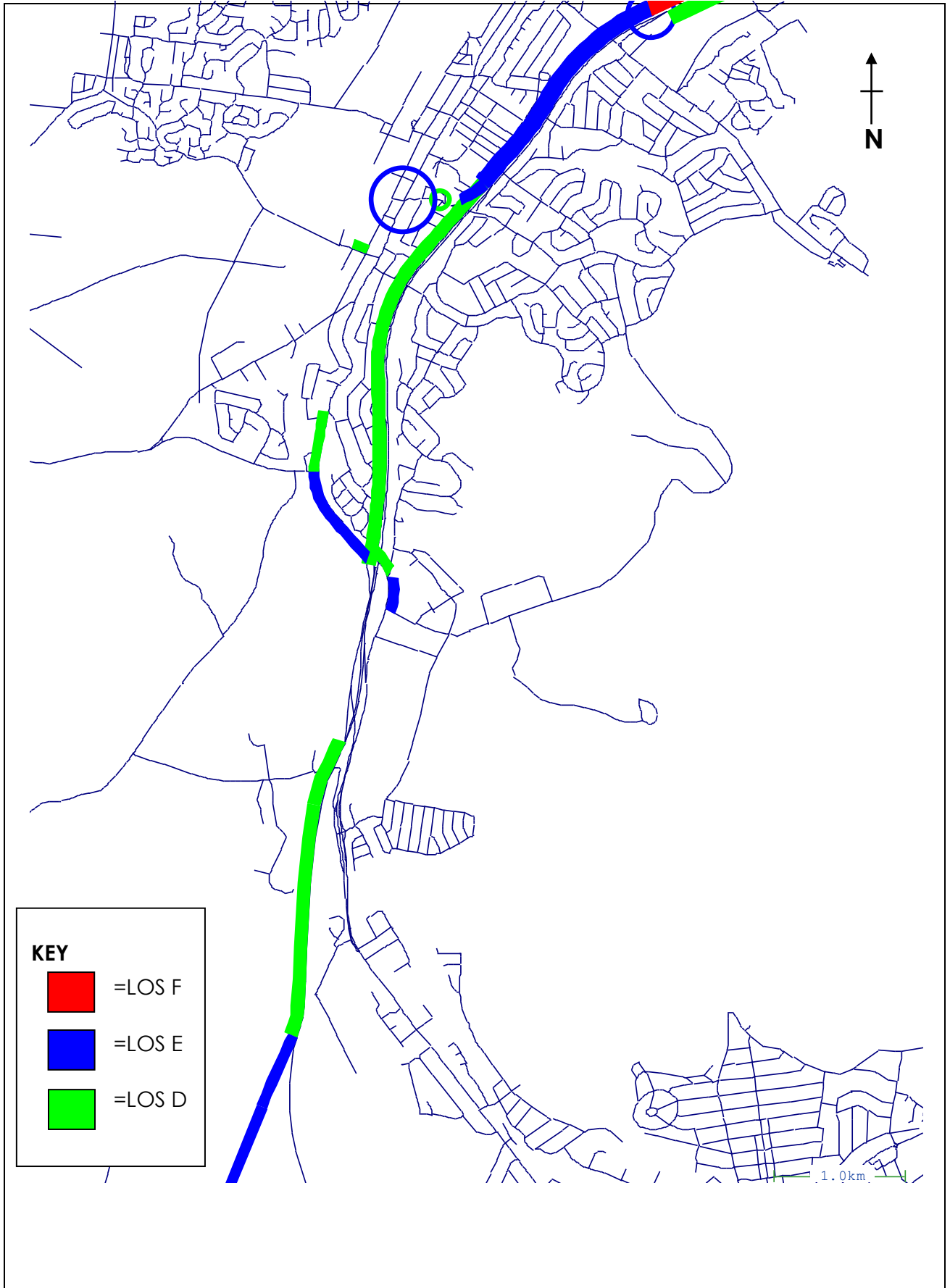

Tallawarra Transportation Model	<b>2036 With Hayward's Link Levels of Service Plot AM Peak</b>	<b>Figure 21</b>
Gabites Porter Consultants		

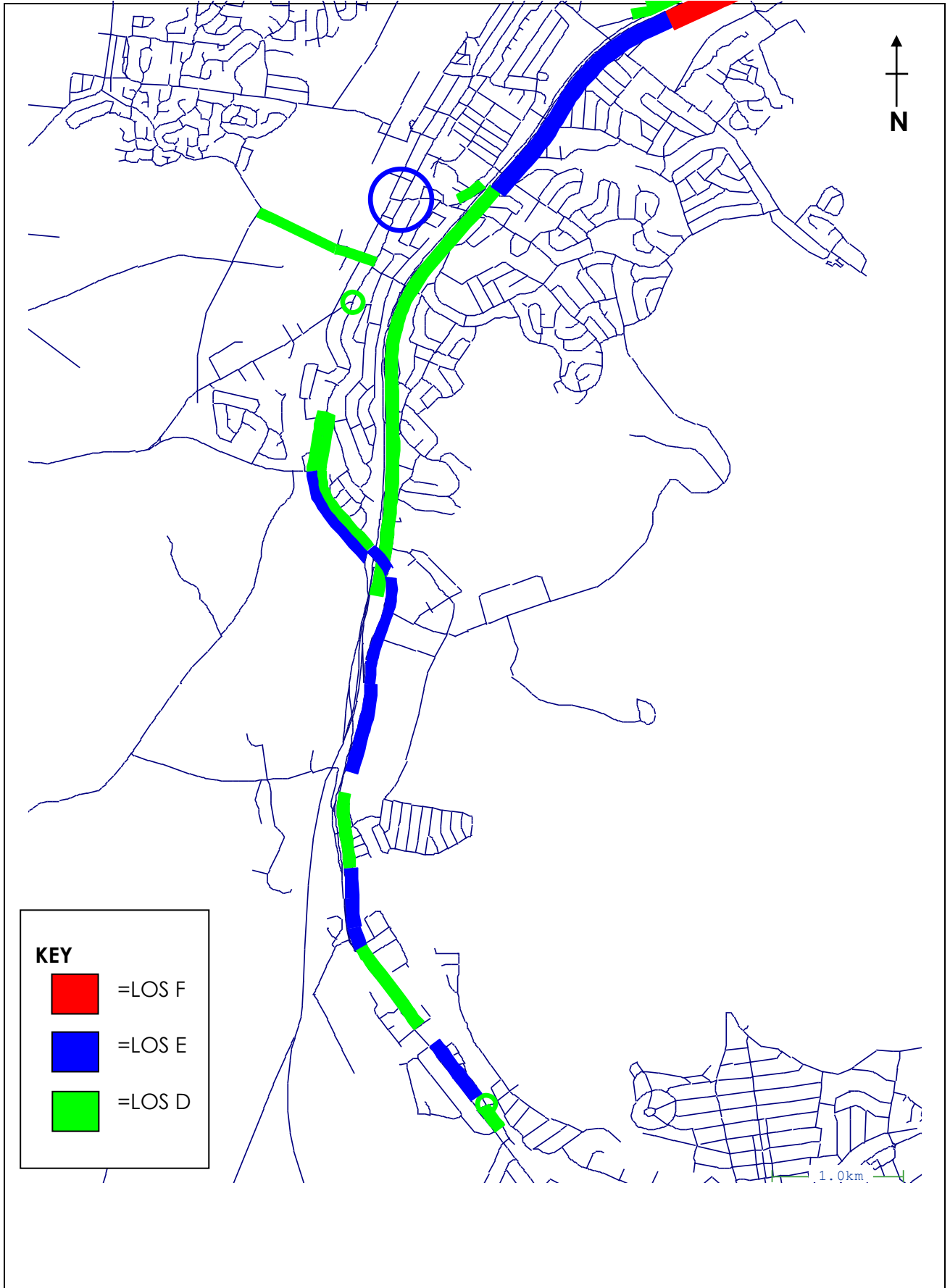

Tallawarra Transportation Model	<b>2036 With Hayward's Link Levels of Service Plot PM Peak</b>	<b>Figure 22</b>
Gabites Porter Consultants		





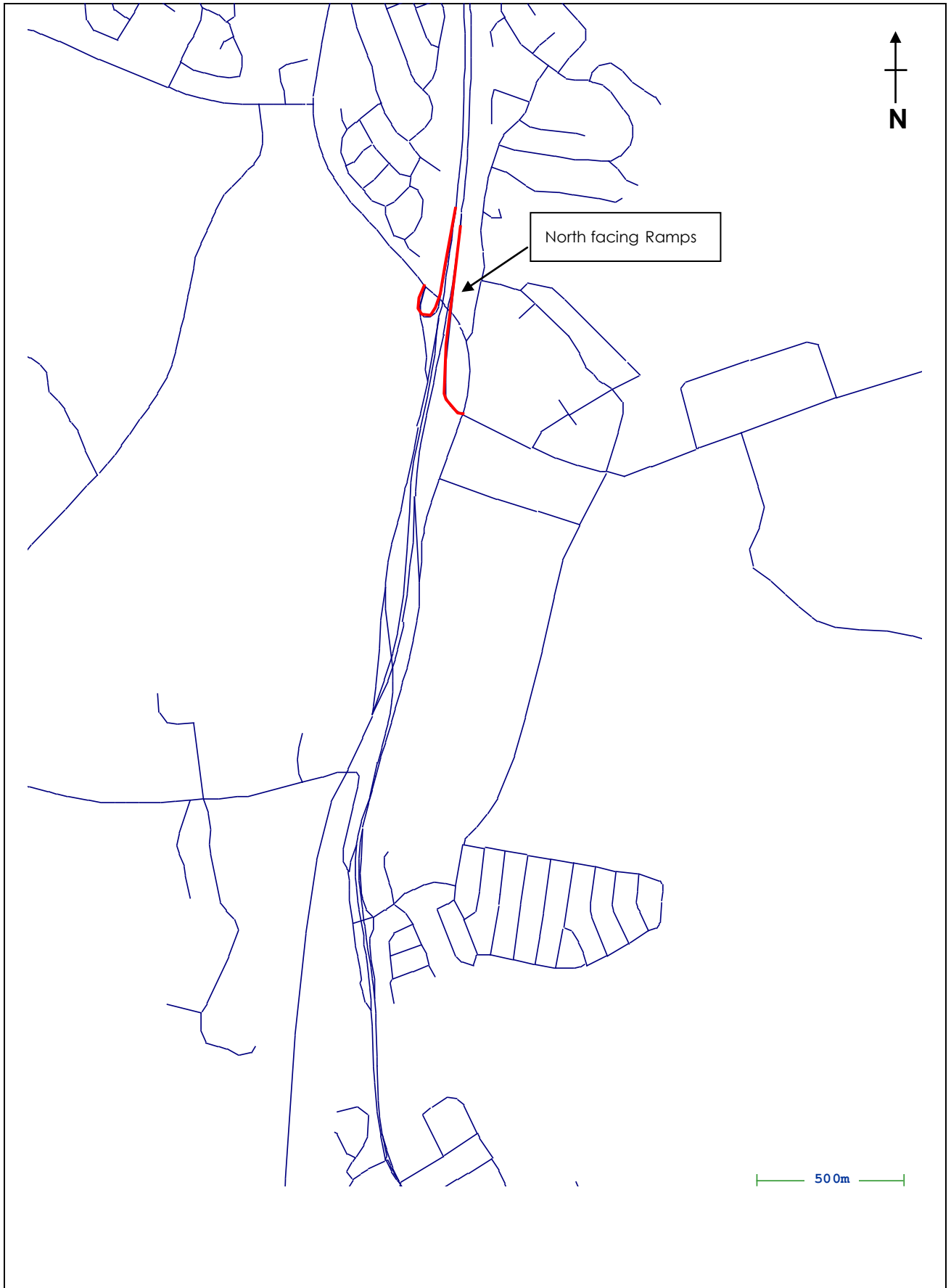

Tallawarra Transportation Model	<b>F6 North Facing Ramps at Tallawarra</b>	<b>Figure 25</b>
Gabites Porter Consultants		



Tallawarra Transportation Model	<b>2036 Base Without Hayward's Link Traffic Volume Plot AM Peak</b>	<b>Figure 26</b>
Gabites Porter Consultants		



Tallawarra Transportation Model	<b>2036 Base Without Hayward's Link With Ramps</b> <b>Traffic Volume Plot</b> <b>AM Peak</b>	<b>Figure 27</b>
Gabites Porter Consultants		





Tallawarra Transportation Model	<b>2036 Base Without Hayward's Link With Ramps</b> <b>Traffic Volume Plot</b> <b>PM Peak</b>	<b>Figure 29</b>
Gabites Porter Consultants		

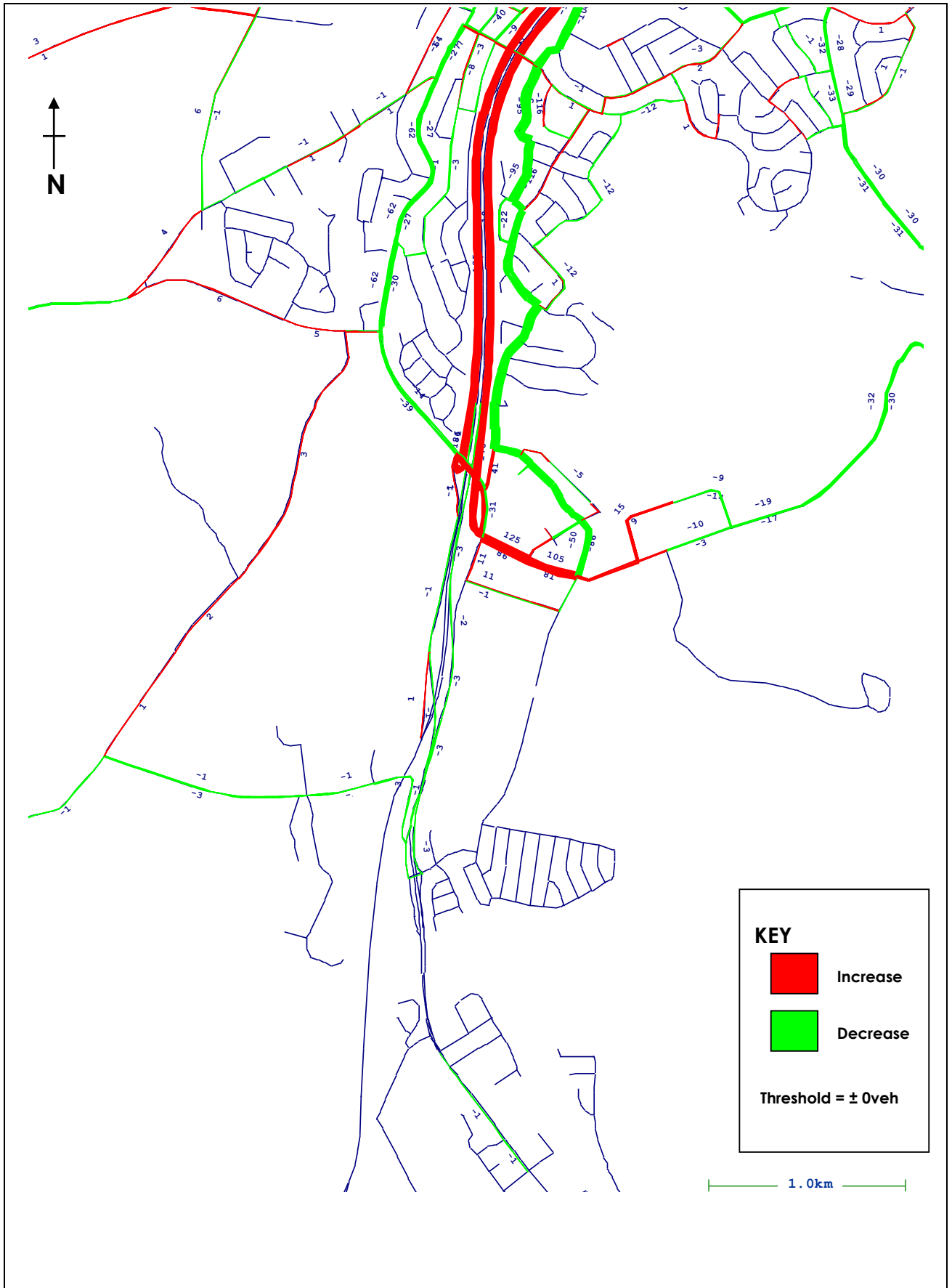

Tallawarra Transportation Model	<b>2036 Base With vs Without Ramps Change in Volume Plot AM Peak</b>	<b>Figure 30</b>
Gabites Porter Consultants		

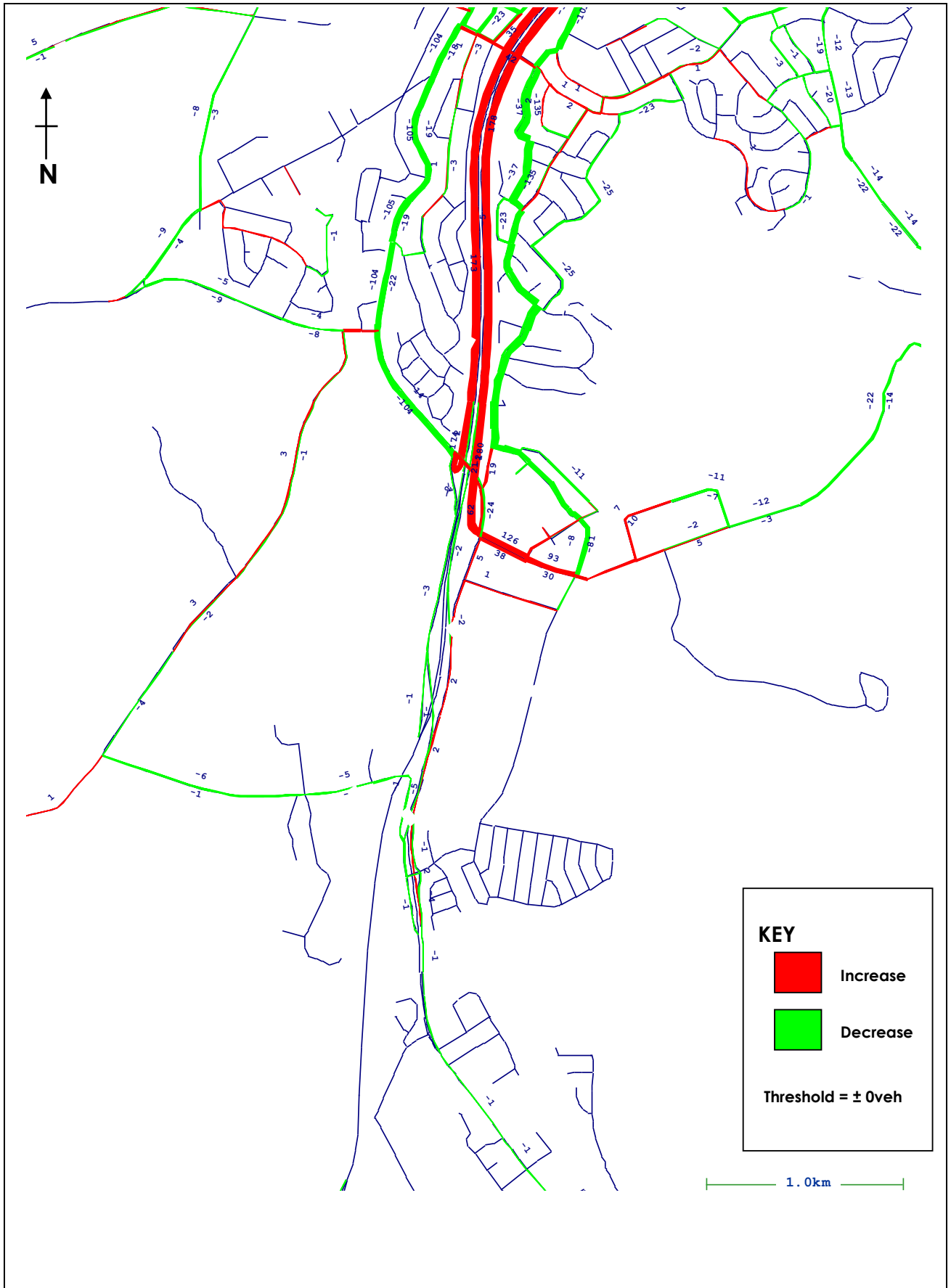

Tallawarra Transportation Model	<b>2036 Base With vs Without Ramps Change in Volume Plot PM Peak</b>	<b>Figure 31</b>
Gabites Porter Consultants		



Tallawarra Transportation Model

Gabites Porter Consultants

**Warren Lee Master Plan**

**Figure 32**

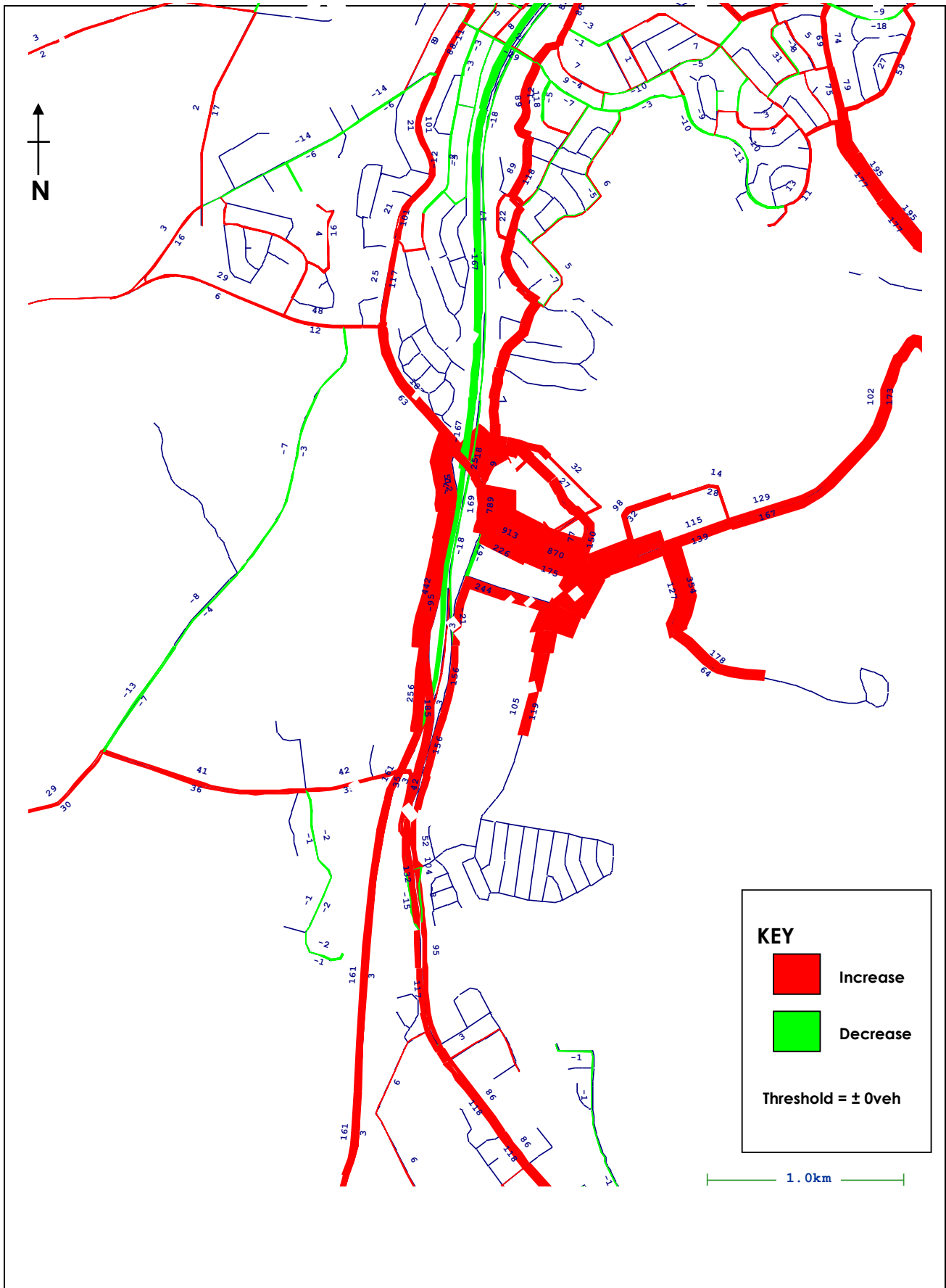

Tallawarra Transportation Model	<b>2036 With Tallawarra vs Without Tallawarra Change in Volume Plot AM Peak</b>	<b>Figure 33</b>
Gabites Porter Consultants		

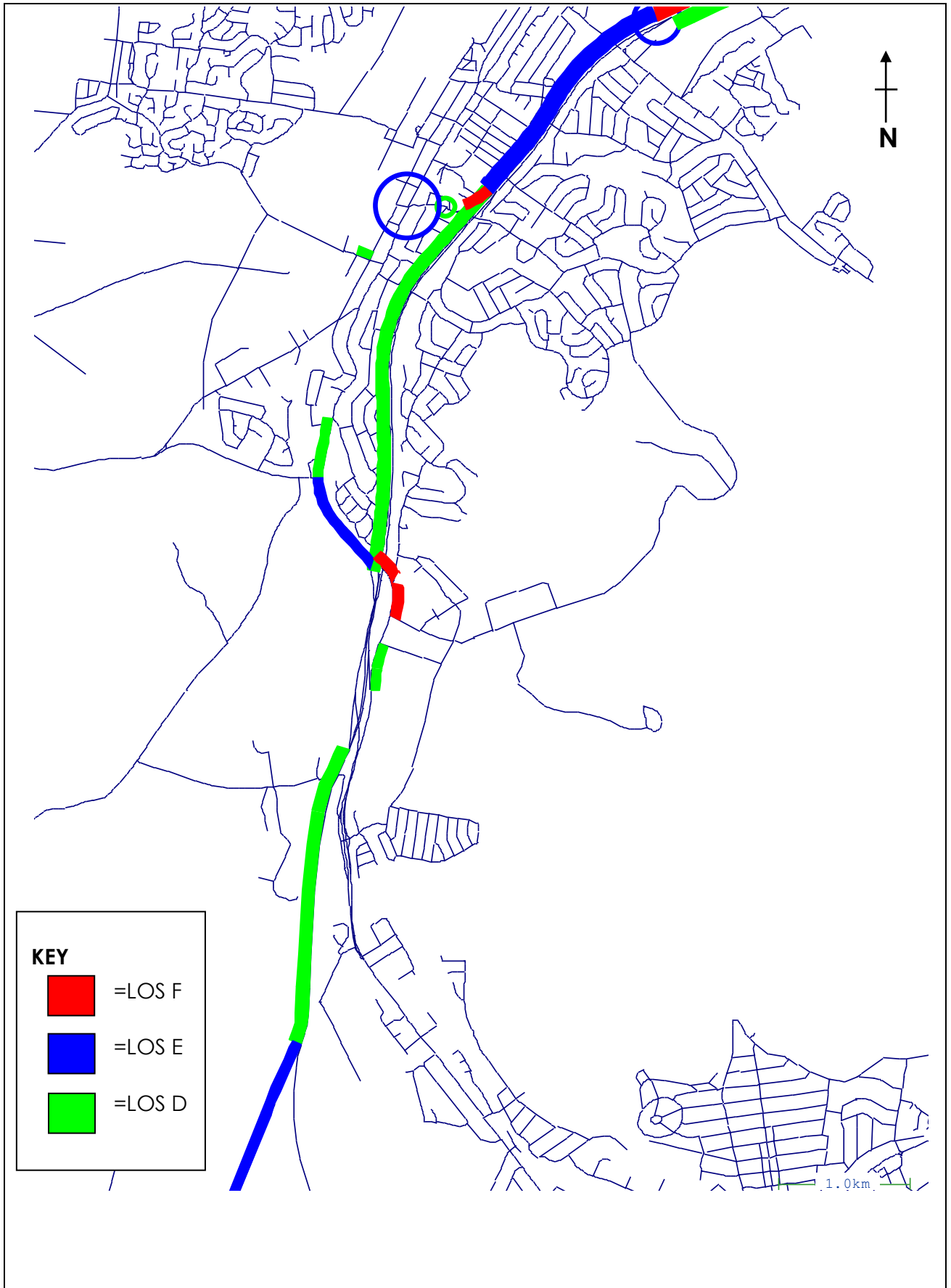

Tallawarra Transportation Model	<b>2036 With Tallawarra – No Hayward's Link</b>	<b>Figure 34</b>
Gabites Porter Consultants	<b>Levels of Service Plot</b>	
	<b>AM Peak</b>	



Tallawarra Transportation Model	<b>2036 Internal Development – No Hayward’s Link Traffic Volume Plot AM Peak</b>	<b>Figure 35</b>
Gabites Porter Consultants		

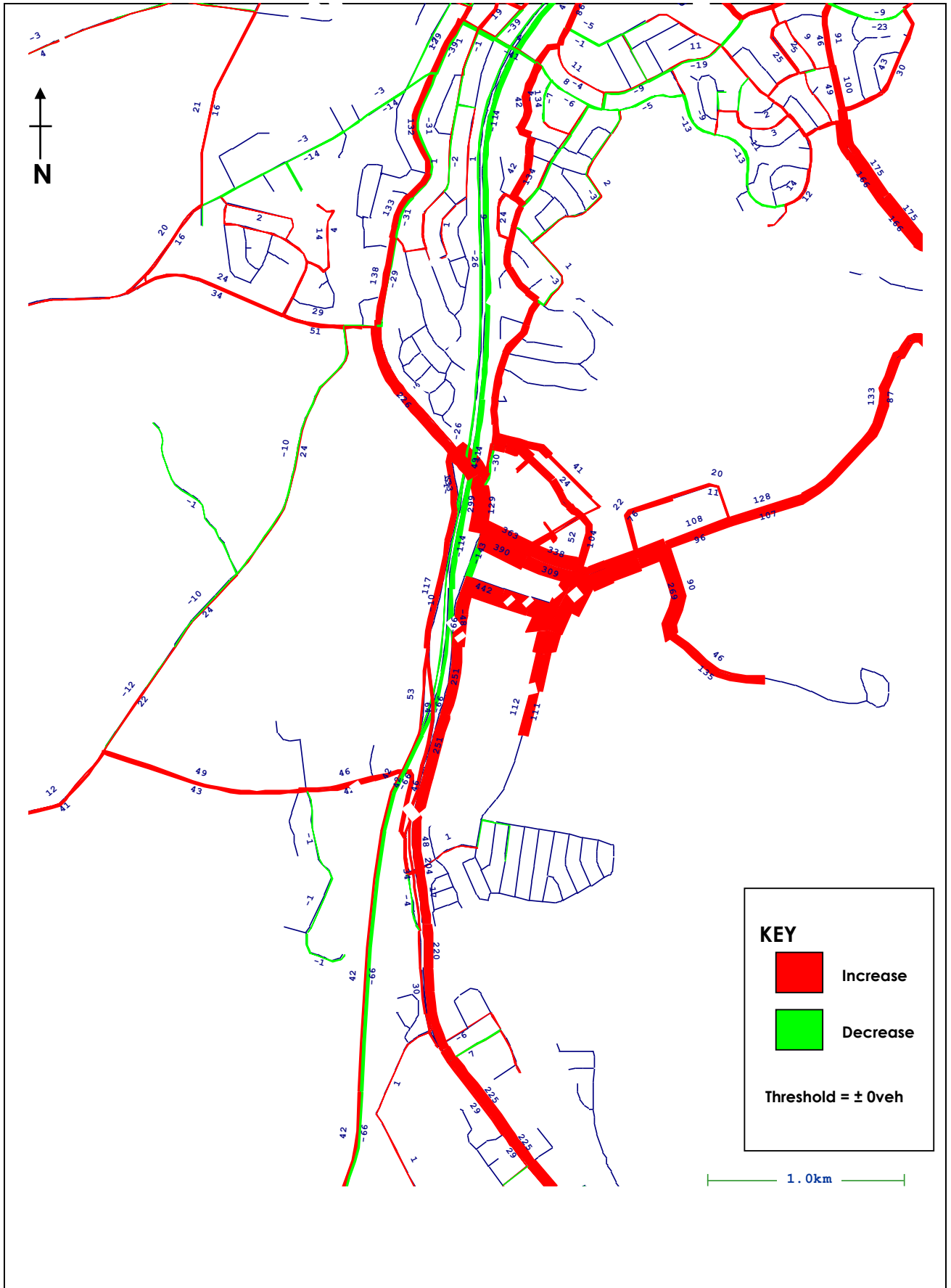

Tallawarra Transportation Model	<b>2036 With Tallawarra vs Without Tallawarra Change in Volume Plot PM Peak</b>	<b>Figure 36</b>
Gabites Porter Consultants		

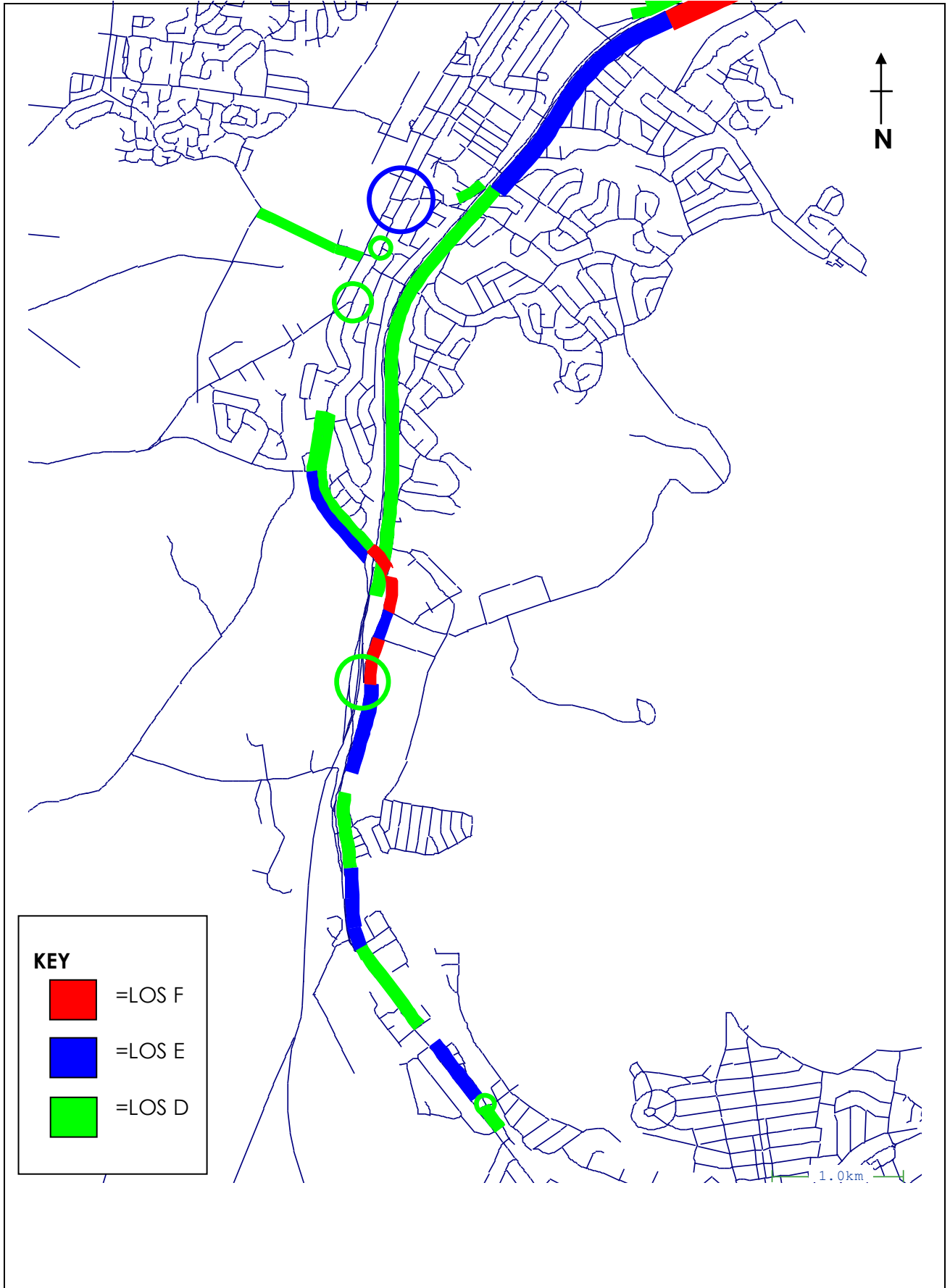

Tallawarra Transportation Model	<b>2036 With Tallawarra – No Hayward’s Link Levels of Service Plot PM Peak</b>	<b>Figure 37</b>
Gabites Porter Consultants		



Tallawarra Transportation Model	<b>2036 Internal Development – No Hayward’s Link Traffic Volume Plot PM Peak</b>	<b>Figure 38</b>
Gabites Porter Consultants		



Tallawarra Transportation Model	<b>2036 Internal Development - With Hayward's Link</b> <b>Traffic Volume Plot</b> <b>AM Peak</b>	<b>Figure 39</b>
Gabites Porter Consultants		



Tallawarra Transportation Model	<b>2036 Internal Development - With Hayward's Link</b> <b>Traffic Volume Plot</b> <b>PM Peak</b>	<b>Figure 40</b>
Gabites Porter Consultants		

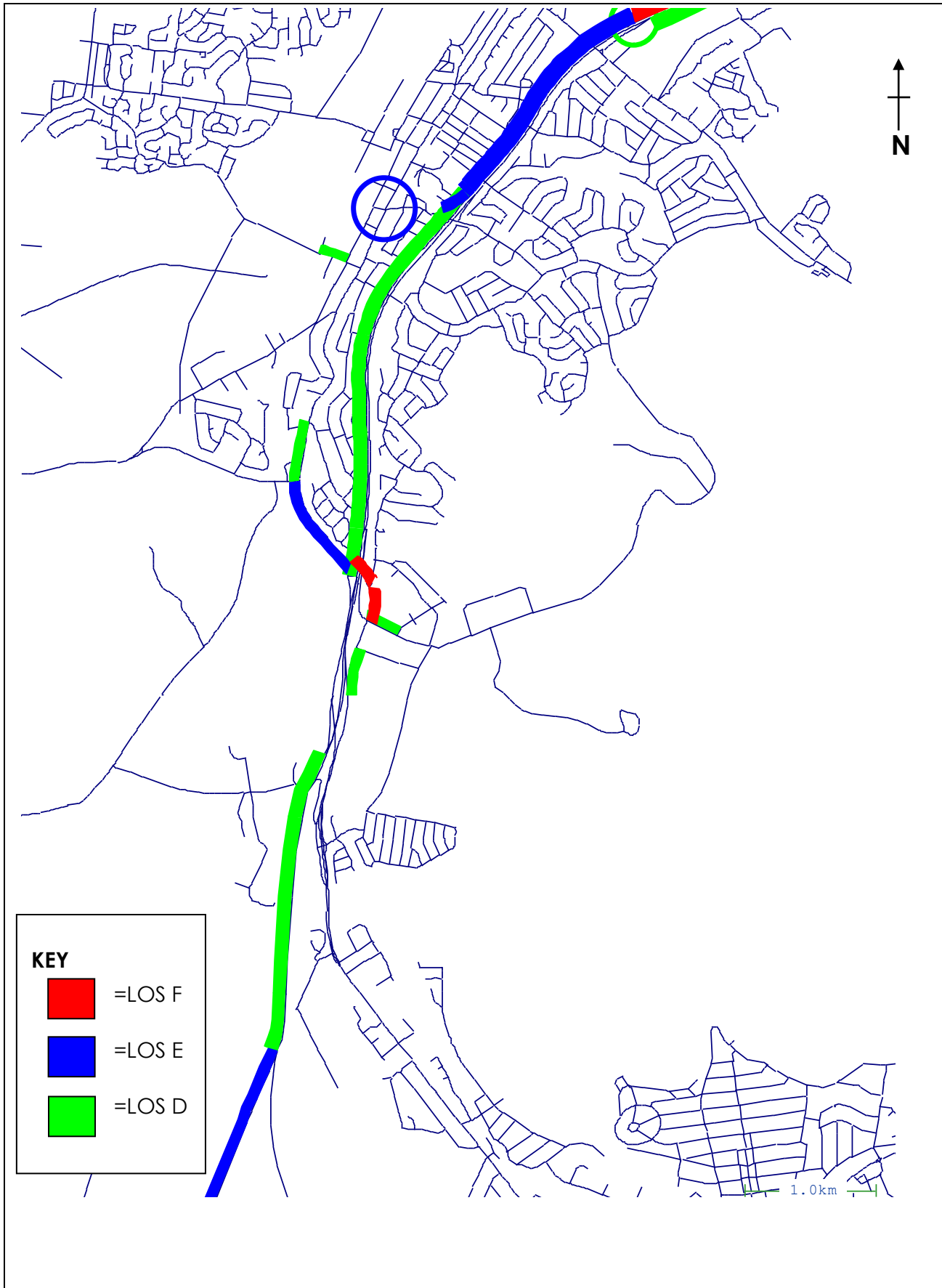

Tallawarra Transportation Model	<b>2036 With F6 Ramps - No Hayward's Link Levels of Service Plot AM Peak</b>	<b>Figure 41</b>
Gabites Porter Consultants		

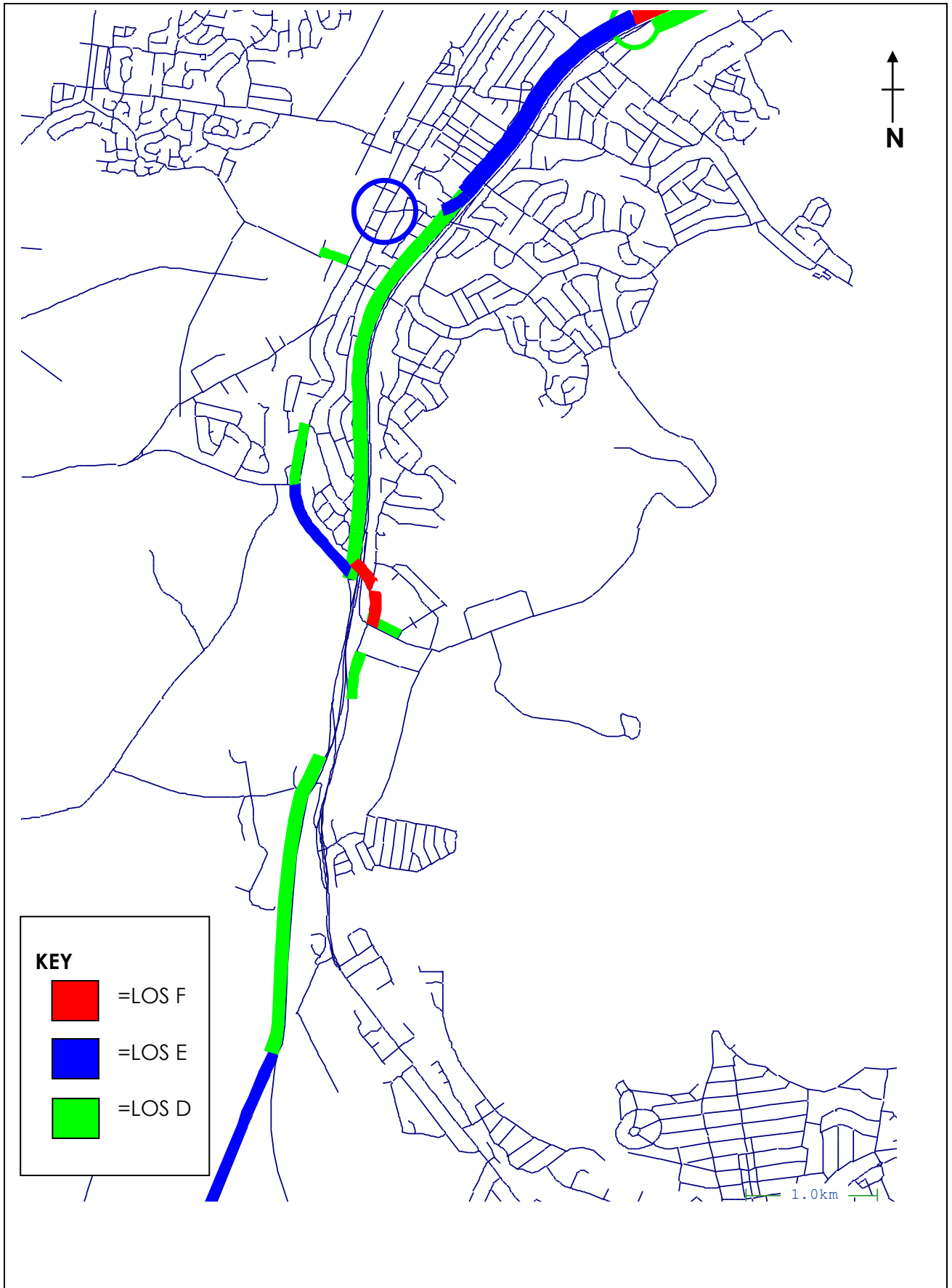

Tallawarra Transportation Model	<b>2036 With F6 Ramps - No Hayward's Link</b>	<b>Figure 42</b>
Gabites Porter Consultants	<b>Levels of Service Plot</b>	
	<b>PM Peak</b>	

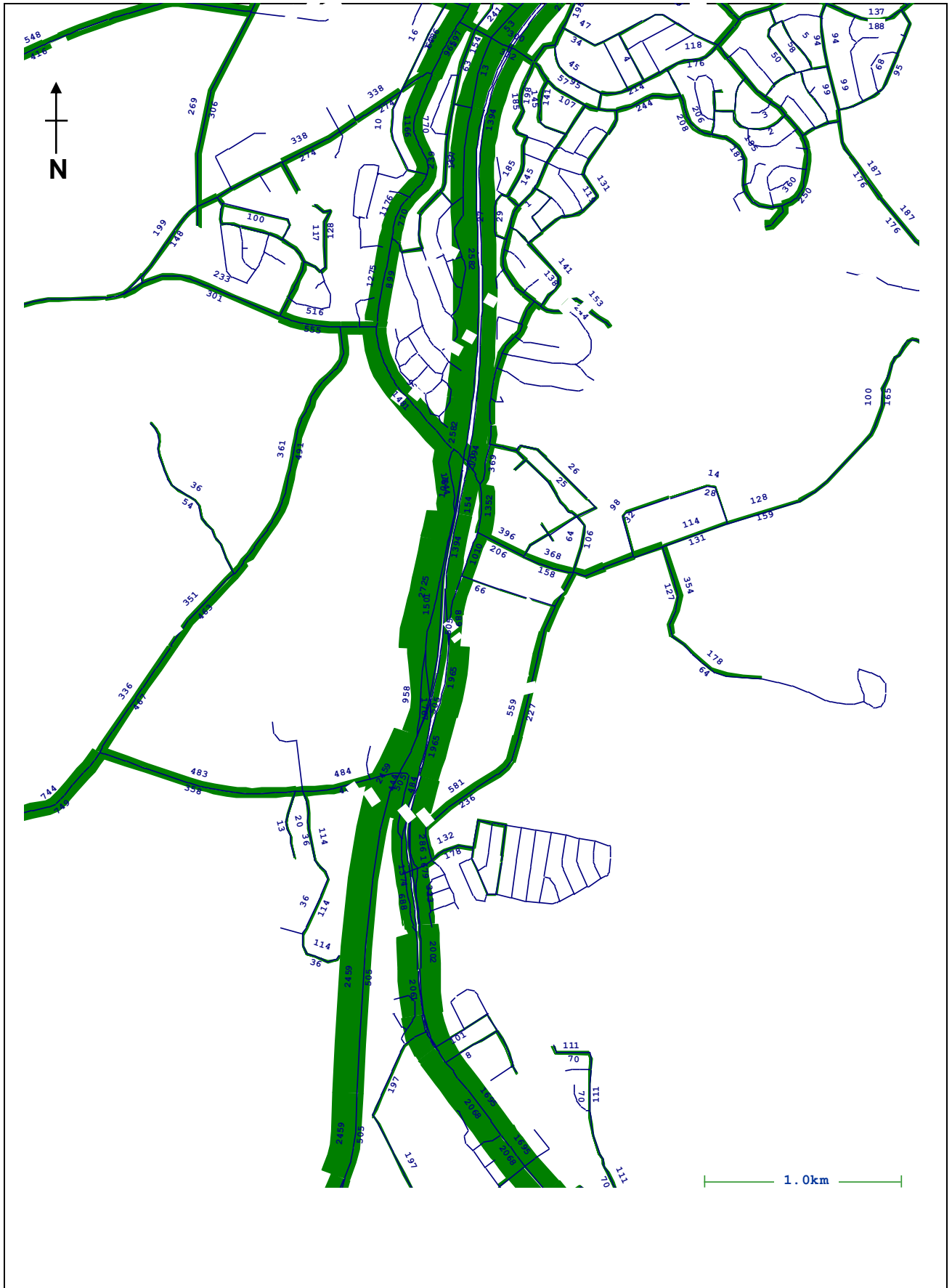

Tallawarra Transportation Model	<b>2036 Alternative Hayward's Bay Link Traffic Volume Plot AM Peak</b>	<b>Figure 43</b>
Gabites Porter Consultants		



Tallawarra Transportation Model	<b>2036 Alternative Hayward's Bay Link Traffic Volume Plot PM Peak</b>	<b>Figure 44</b>
Gabites Porter Consultants		

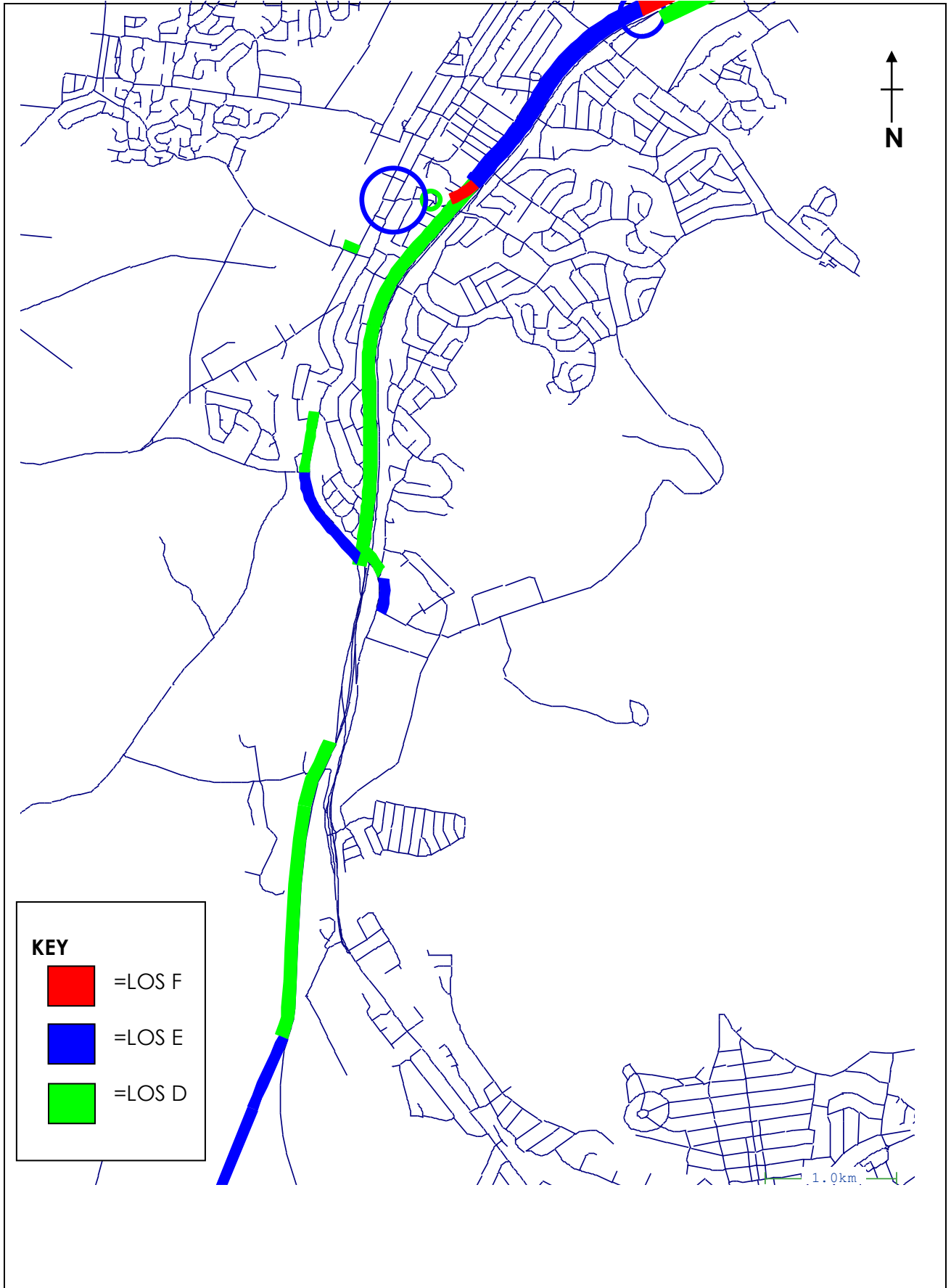

Tallawarra Transportation Model	<b>2036 Alternative Hayward's Bay Link Levels of Service Plot AM Peak</b>	<b>Figure 45</b>
Gabites Porter Consultants		

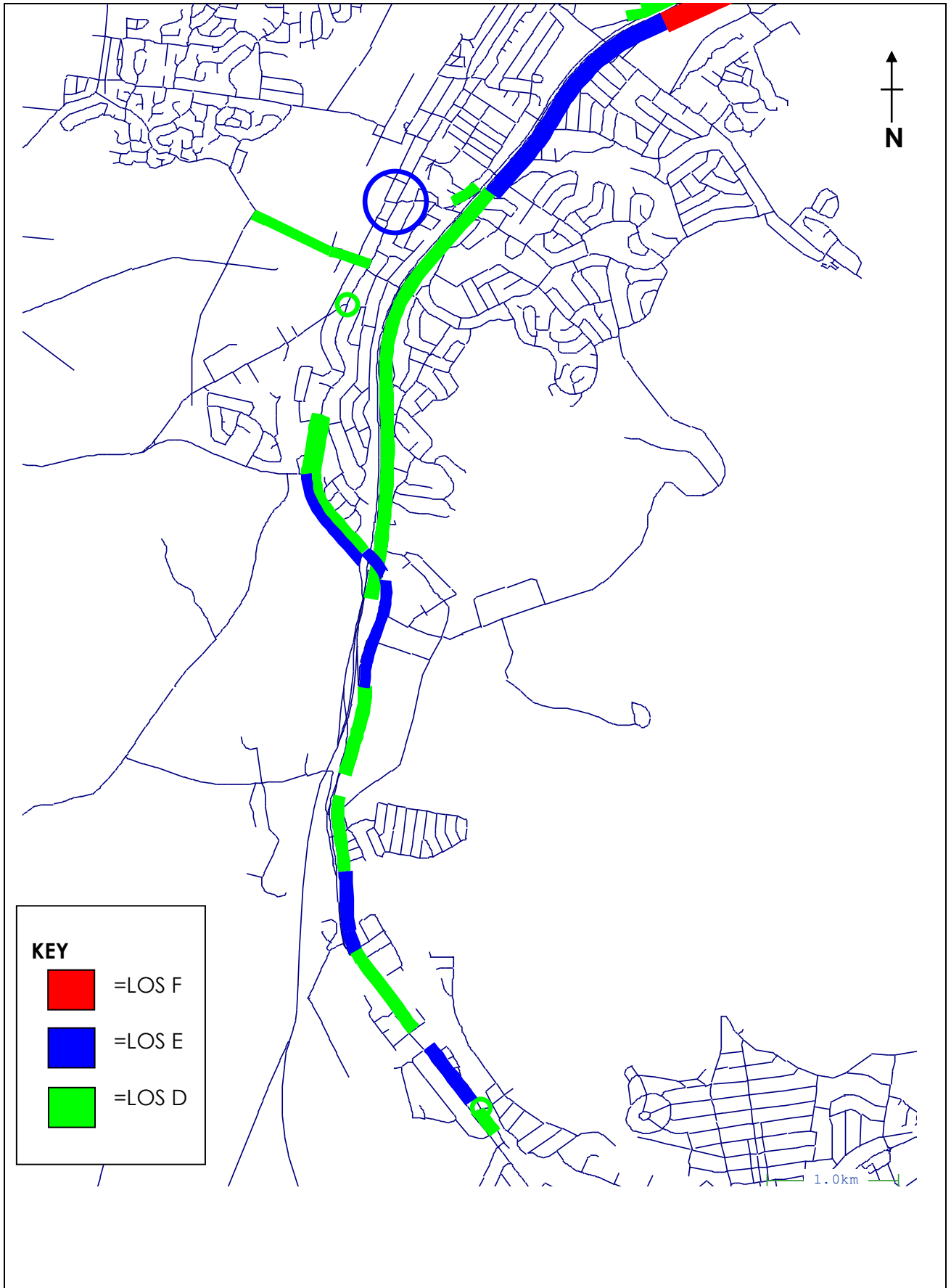

Tallawarra Transportation Model	<b>2036 Alternative Hayward's Bay Link Levels of Service Plot PM Peak</b>	<b>Figure 46</b>
Gabites Porter Consultants		



Tallawarra Transportation Model	<b>2036 Yallah Rd Link Traffic Volume Plot AM Peak</b>	<b>Figure 47</b>
Gabites Porter Consultants		



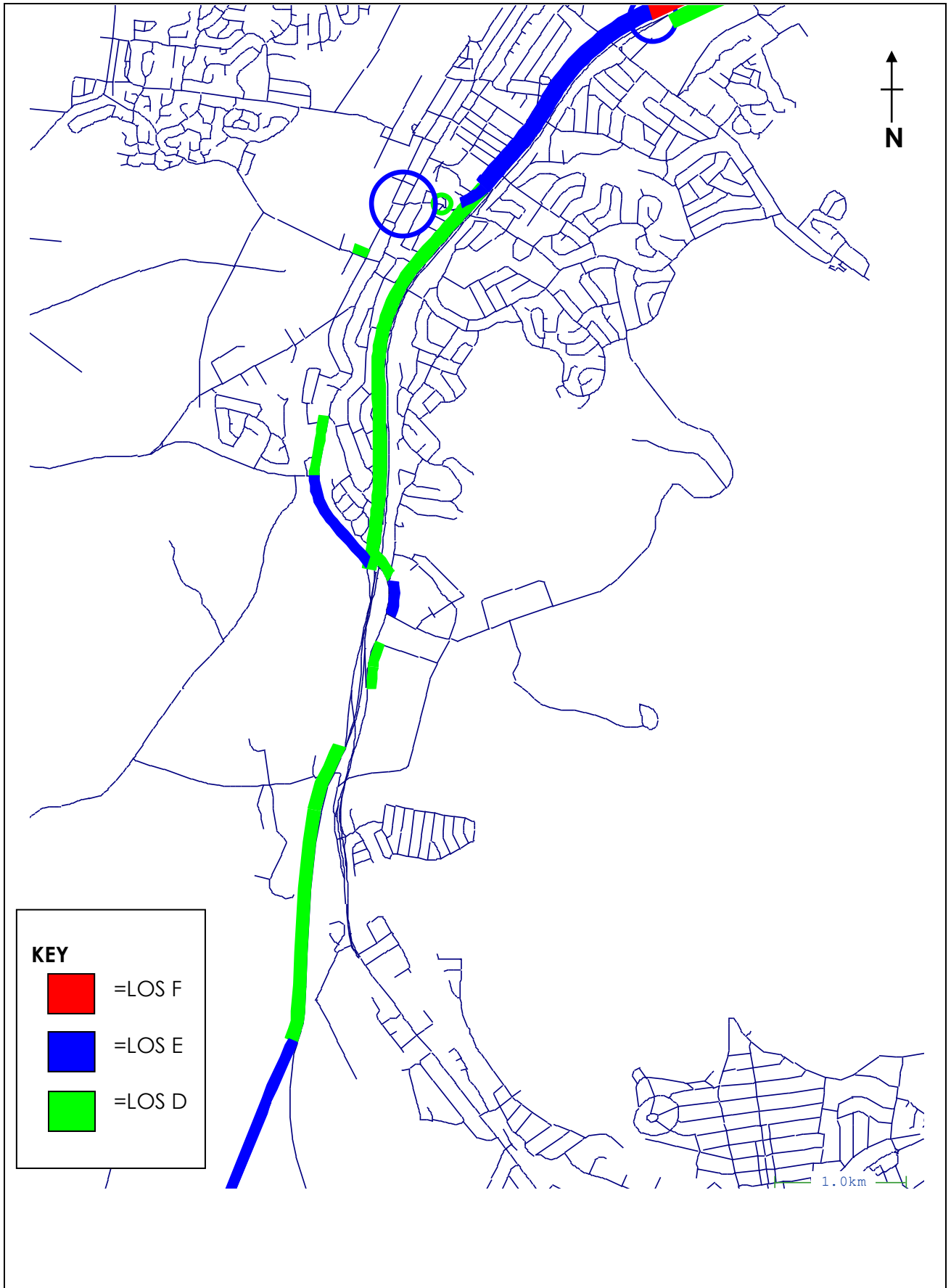

Tallawarra Transportation Model	<b>2036 Yallah Rd Link Levels of Service Plot AM Peak</b>	<b>Figure 49</b>
Gabites Porter Consultants		

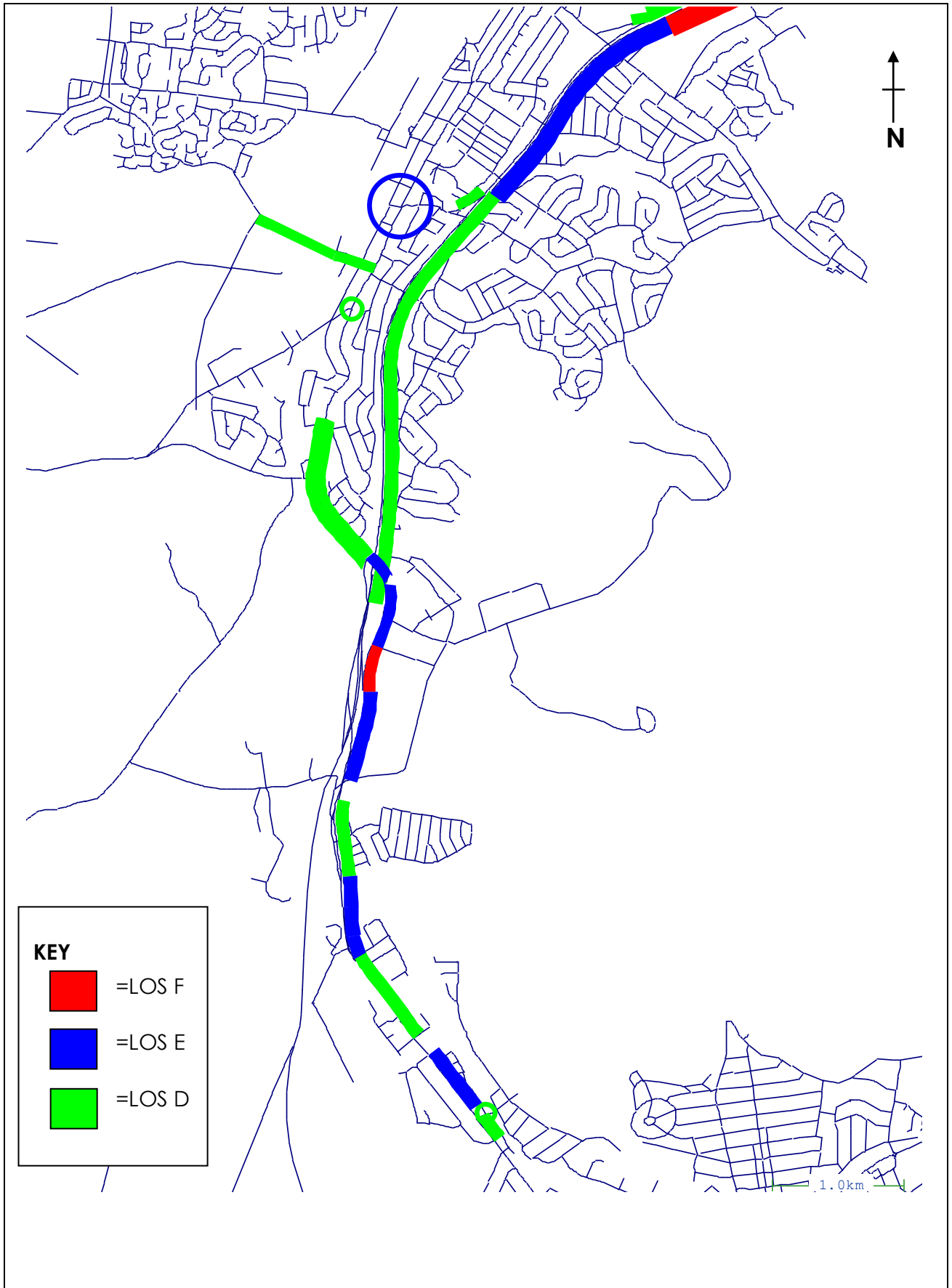

Tallawarra Transportation Model	<b>2036 Yallah Rd Link Levels of Service Plot PM Peak</b>	<b>Figure 50</b>
Gabites Porter Consultants		



Tallawarra Transportation Model	<b>2036 No Cormack Ave Connection to Princes Highway</b> <b>Traffic Volume Plot</b> <b>AM Peak</b>	<b>Figure 51</b>
Gabites Porter Consultants		



Tallawarra Transportation Model	<b>2036 No Cormack Ave Connection to Princes Highway Traffic Volume Plot PM Peak</b>	<b>Figure 52</b>
Gabites Porter Consultants		

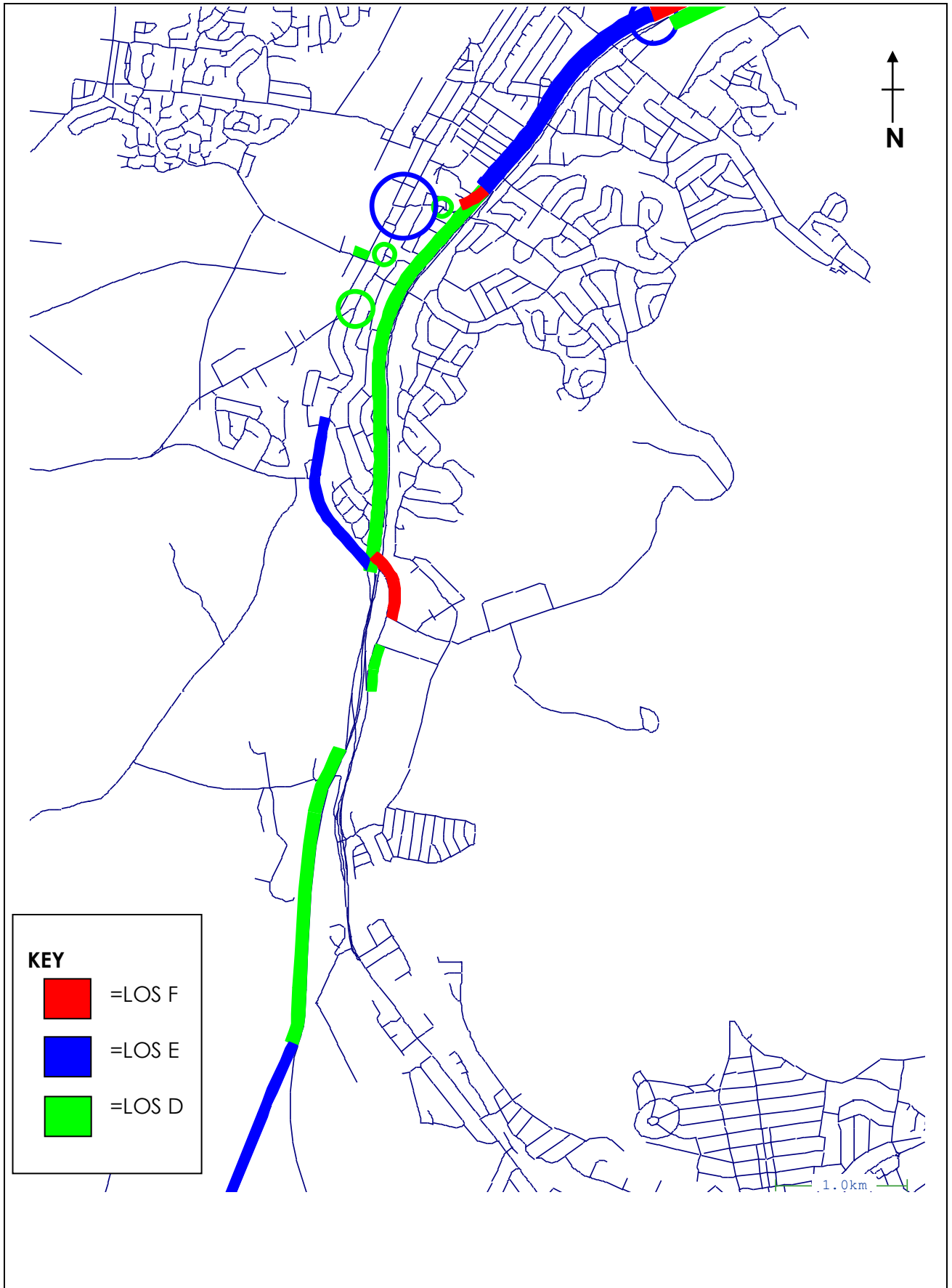

Tallawarra Transportation Model	<b>2036 No Cormack Ave Connection to Princes Highway</b>	<b>Figure 53</b>
Gabites Porter Consultants	<b>Levels of Service Plot AM Peak</b>	

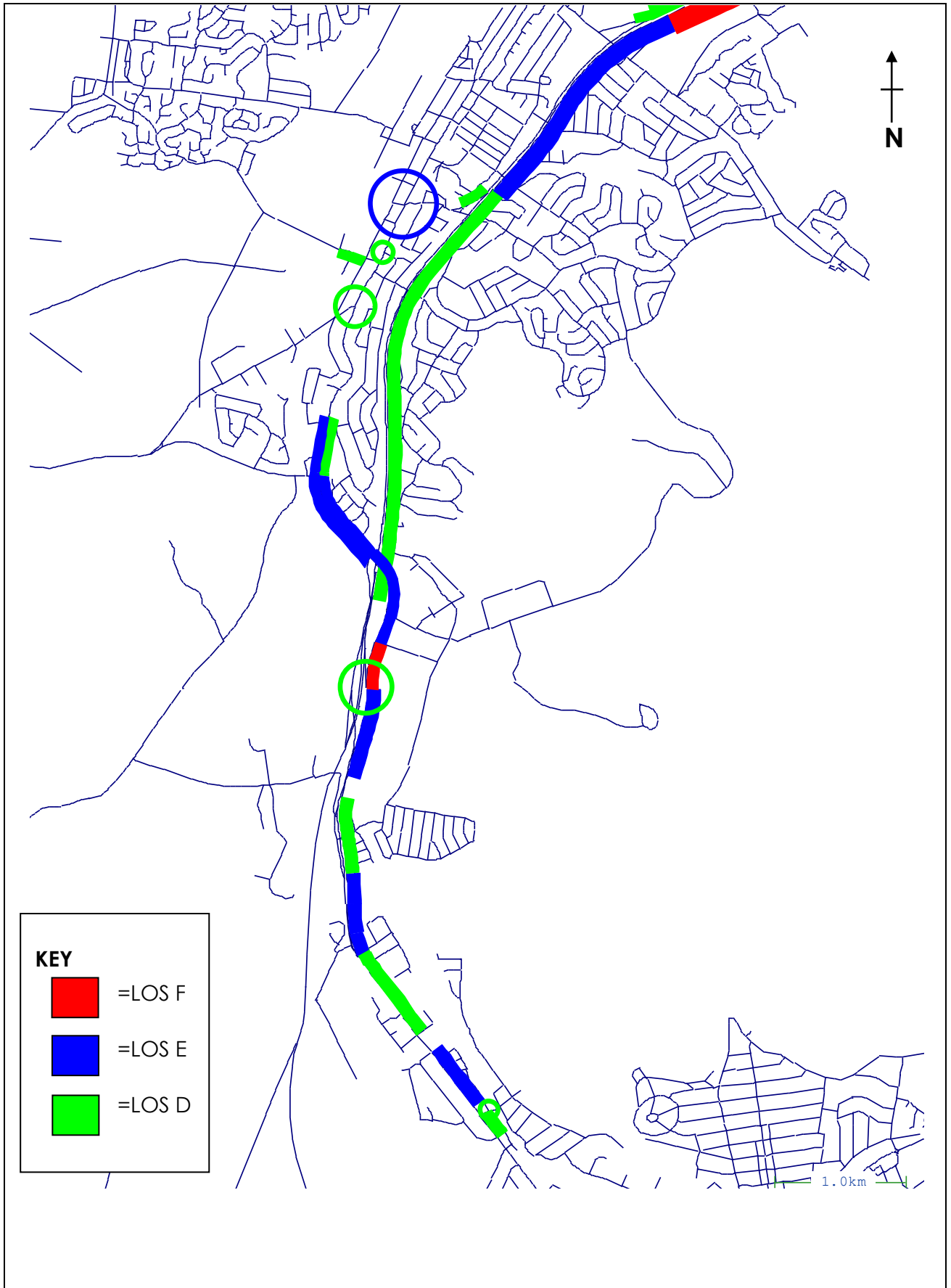

Tallawarra Transportation Model	<b>2036 No Cormack Ave Connection to Princes Highway Levels of Service Plot PM Peak</b>	<b>Figure 54</b>
Gabites Porter Consultants		

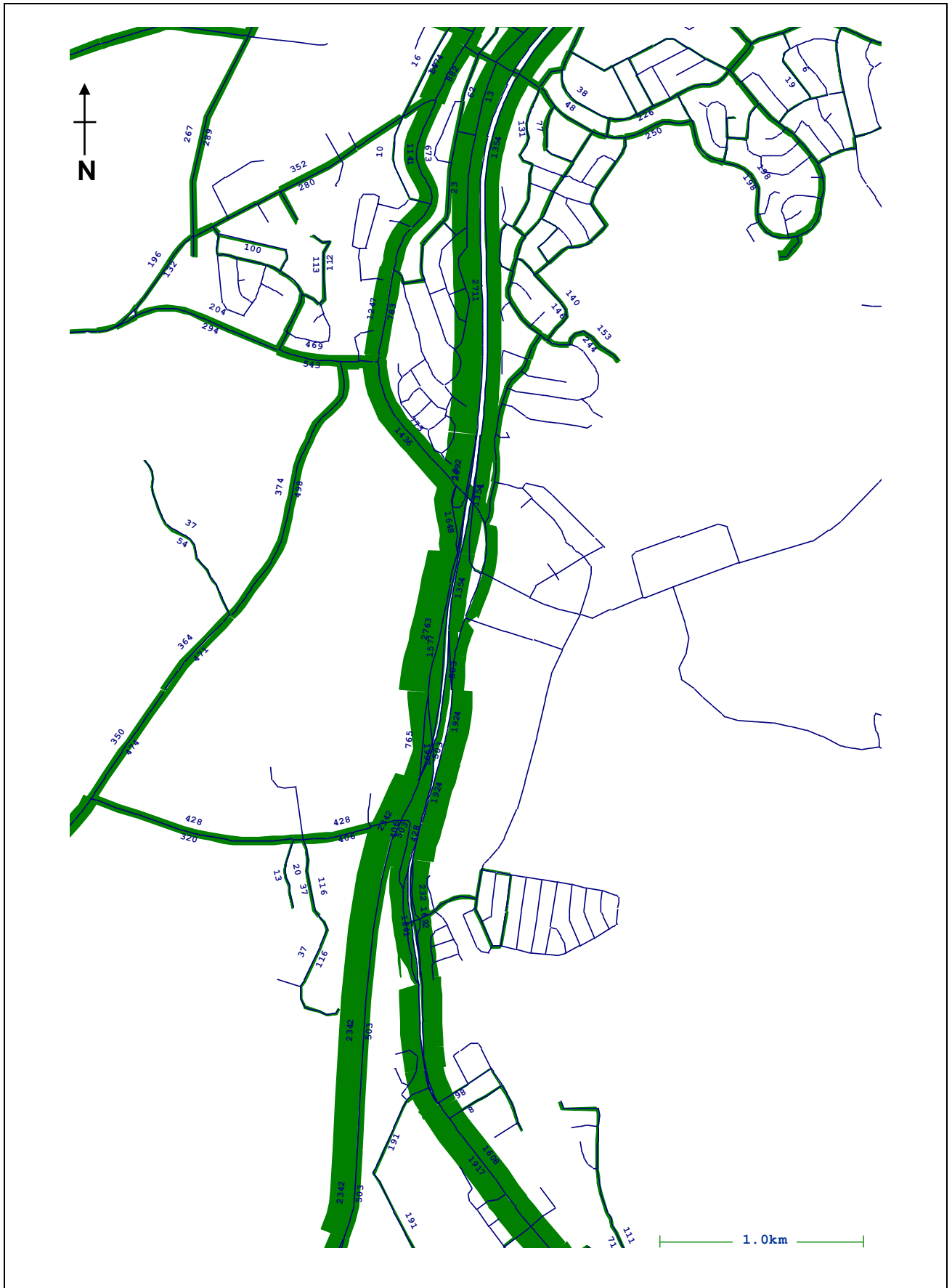

Tallawarra Transportation Model	<b>2036 F6 Ramps + Haywards Bay Link</b> <b>No Tallawarra</b> <b>Traffic Volume Plot</b> <b>AM Peak</b>	<b>Figure 55</b>
Gabites Porter Consultants		



Tallawarra Transportation Model	<b>2036 F6 Ramps + Haywards Bay Link With Tallawarra Traffic Volume Plot AM Peak</b>	<b>Figure 56</b>
Gabites Porter Consultants		



Tallawarra Transportation Model	<b>2036 F6 Ramps + Haywards Bay Link</b> <b>No Tallawarra</b> <b>Traffic Volume Plot</b> <b>PM Peak</b>	<b>Figure 57</b>
Gabites Porter Consultants		



Tallawarra Transportation Model	<b>2036 F6 Ramps + Haywards Bay Link With Tallawarra Traffic Volume Plot PM Peak</b>	<b>Figure 58</b>
Gabites Porter Consultants		



Tallawarra Transportation Model	<b>2036 F6 Ramps + Haywards Bay Link</b> <b>No Tallawarra</b> <b>Levels of Service Plot</b> <b>AM Peak</b>	<b>Figure 59</b>
Gabites Porter Consultants		



Tallawarra Transportation Model	<b>2036 F6 Ramps + Haywards Bay Link With Tallawarra Levels of Service Plot AM Peak</b>	<b>Figure 60</b>
Gabites Porter Consultants		

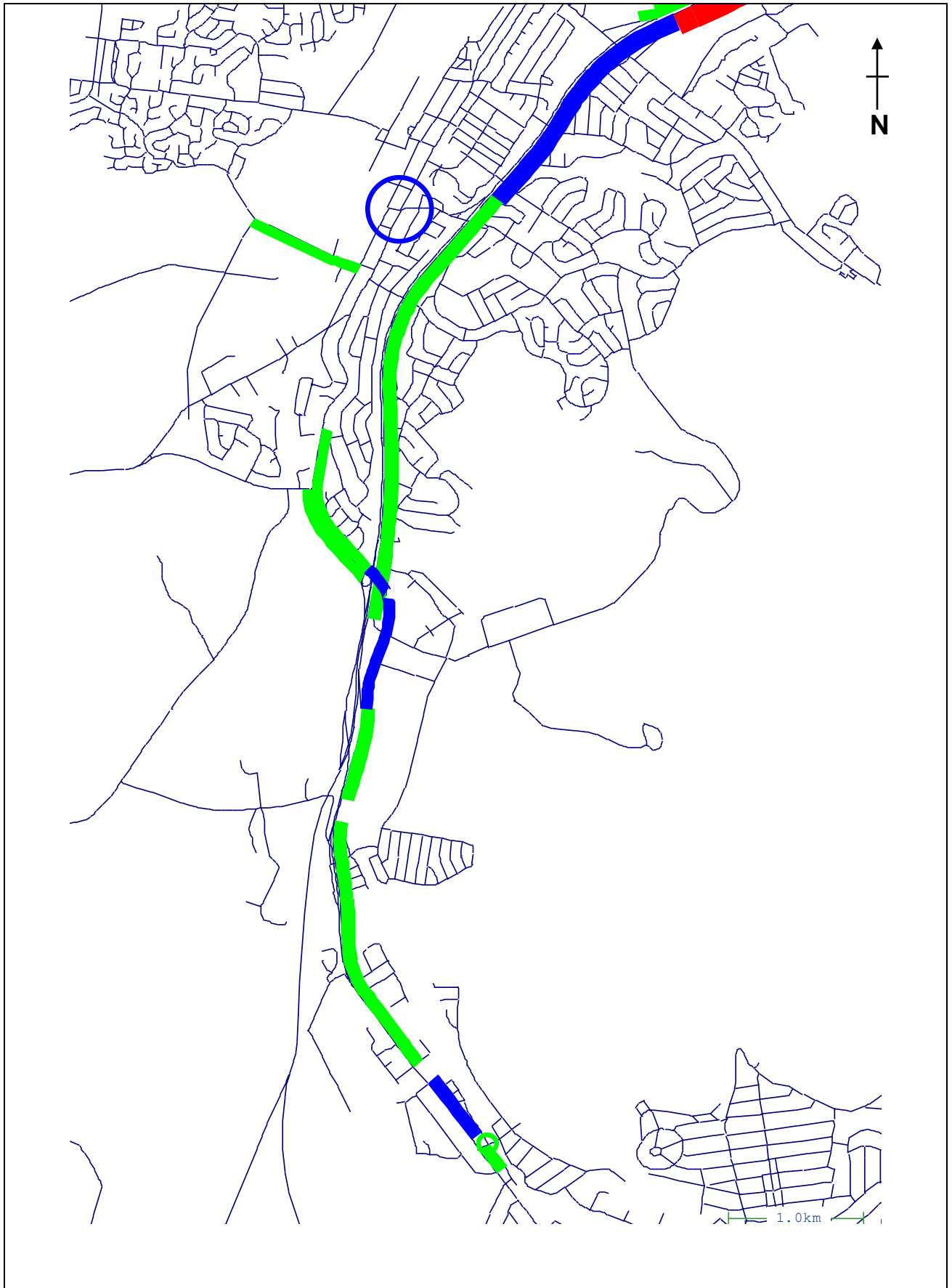

Tallawarra Transportation Model	<b>2036 F6 Ramps + Haywards Bay Link</b> <b>No Tallawarra</b> <b>Levels of Service Plot</b> <b>PM Peak</b>	<b>Figure 61</b>
Gabites Porter Consultants		

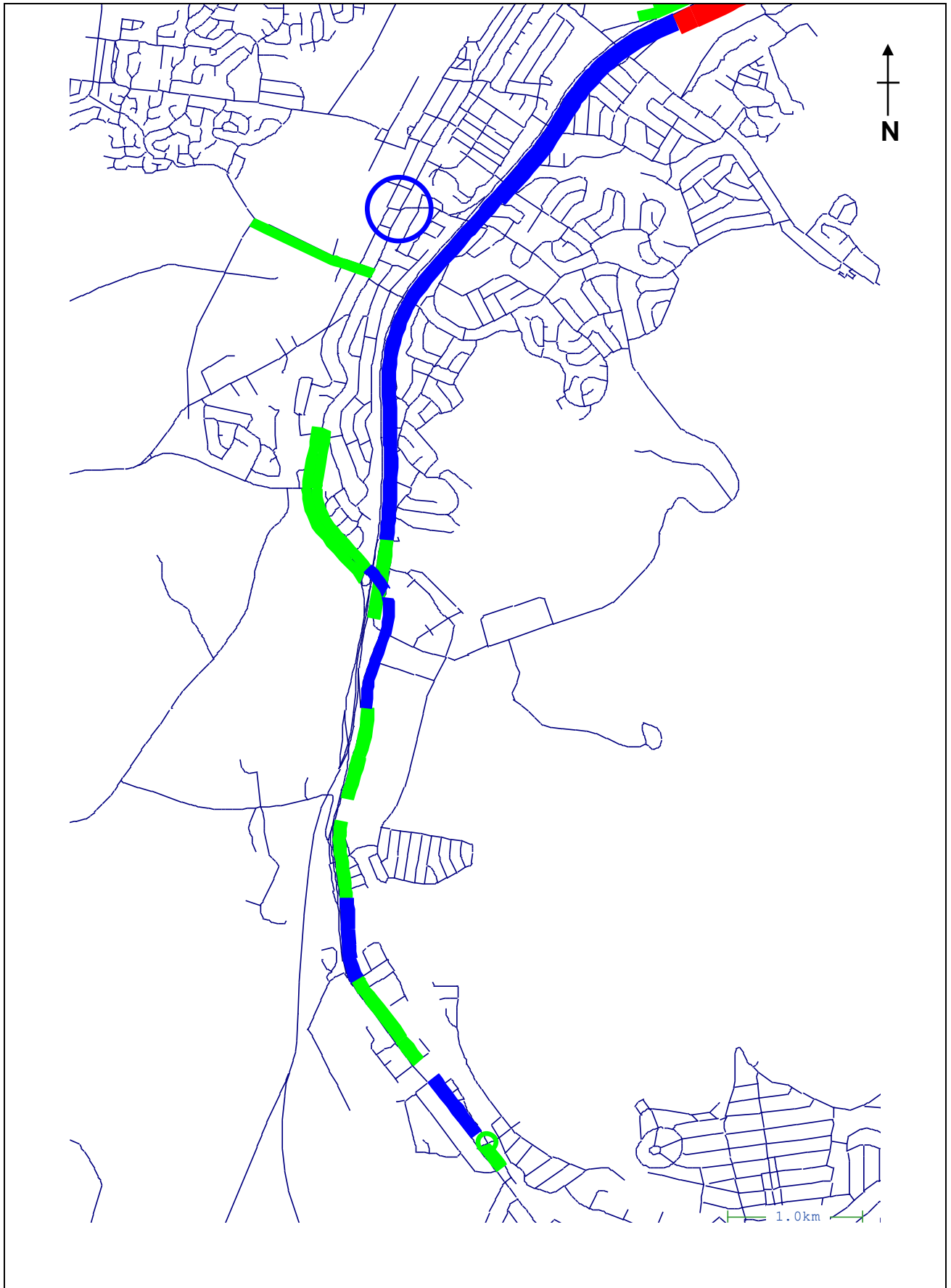

Tallawarra Transportation Model	<b>2036 F6 Ramps + Haywards Bay Link With Tallawarra Levels of Service Plot PM Peak</b>	<b>Figure 62</b>
Gabites Porter Consultants		

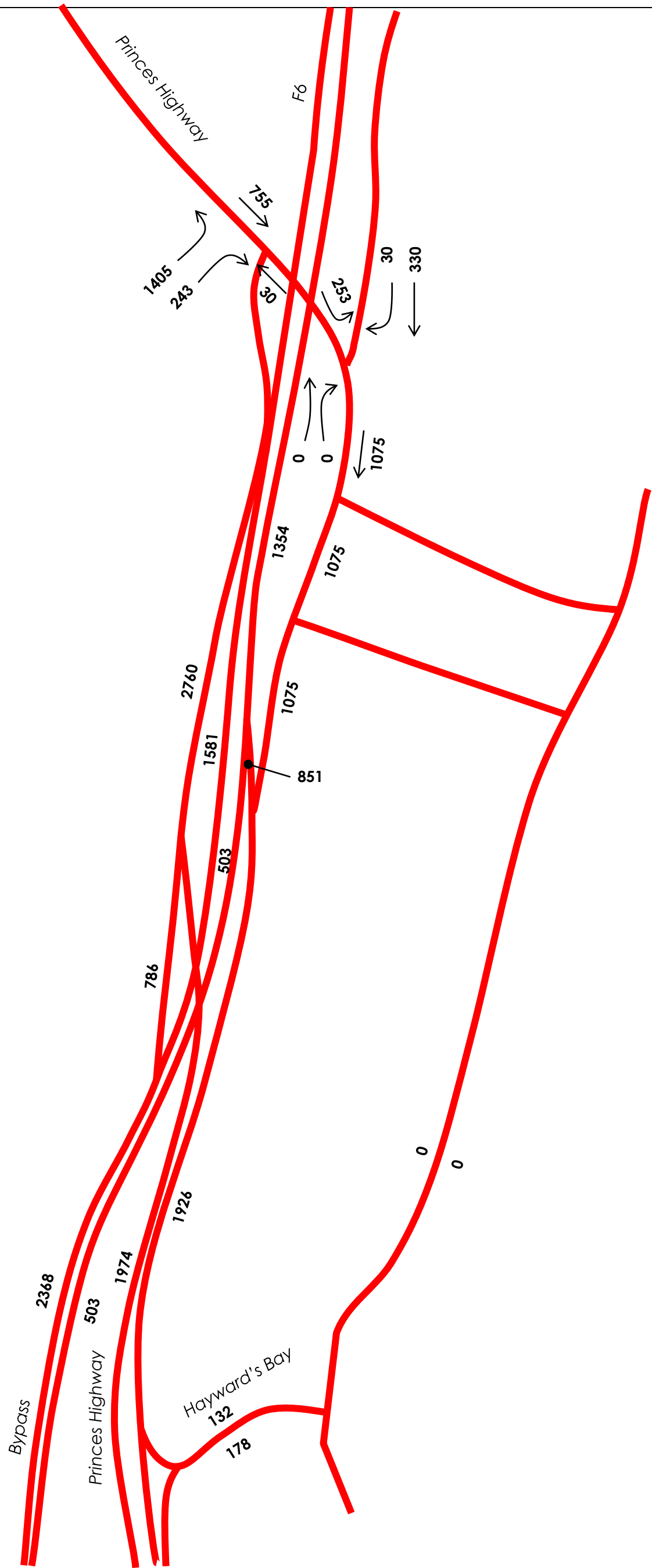

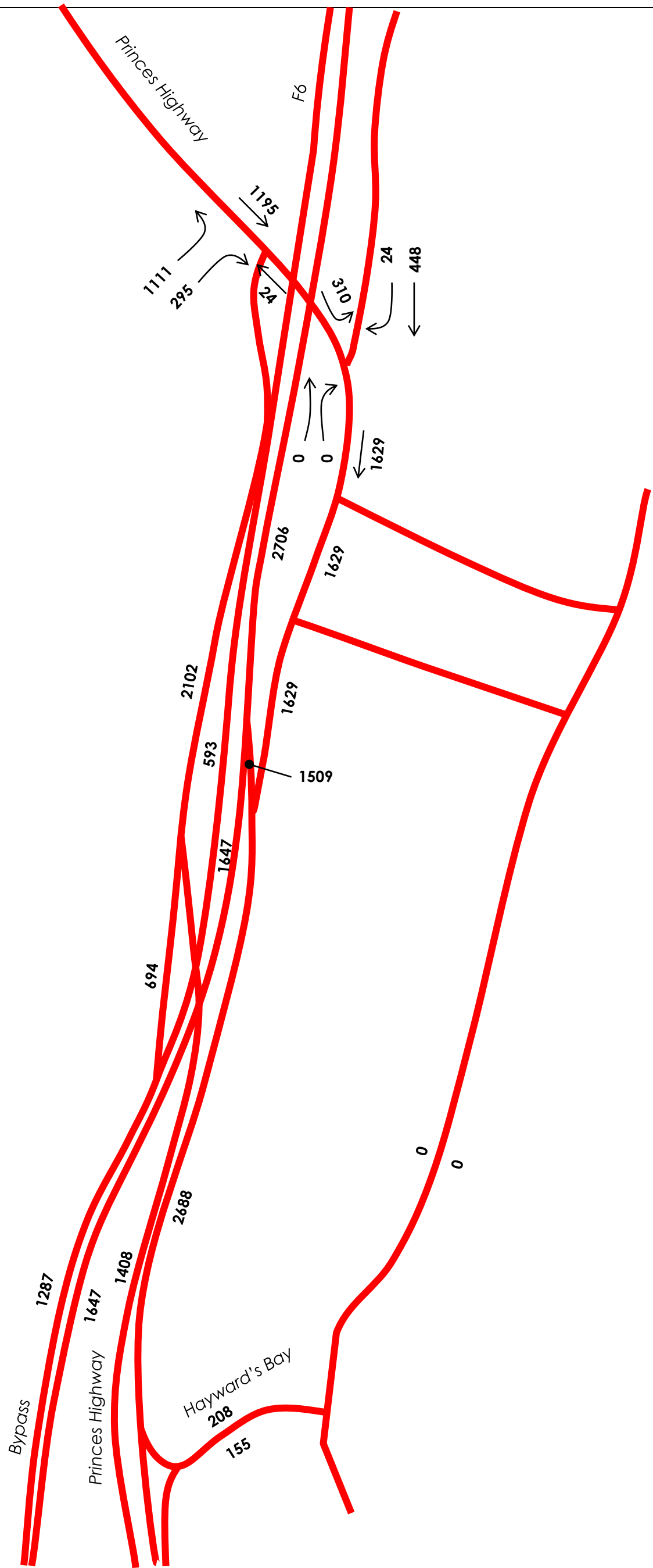

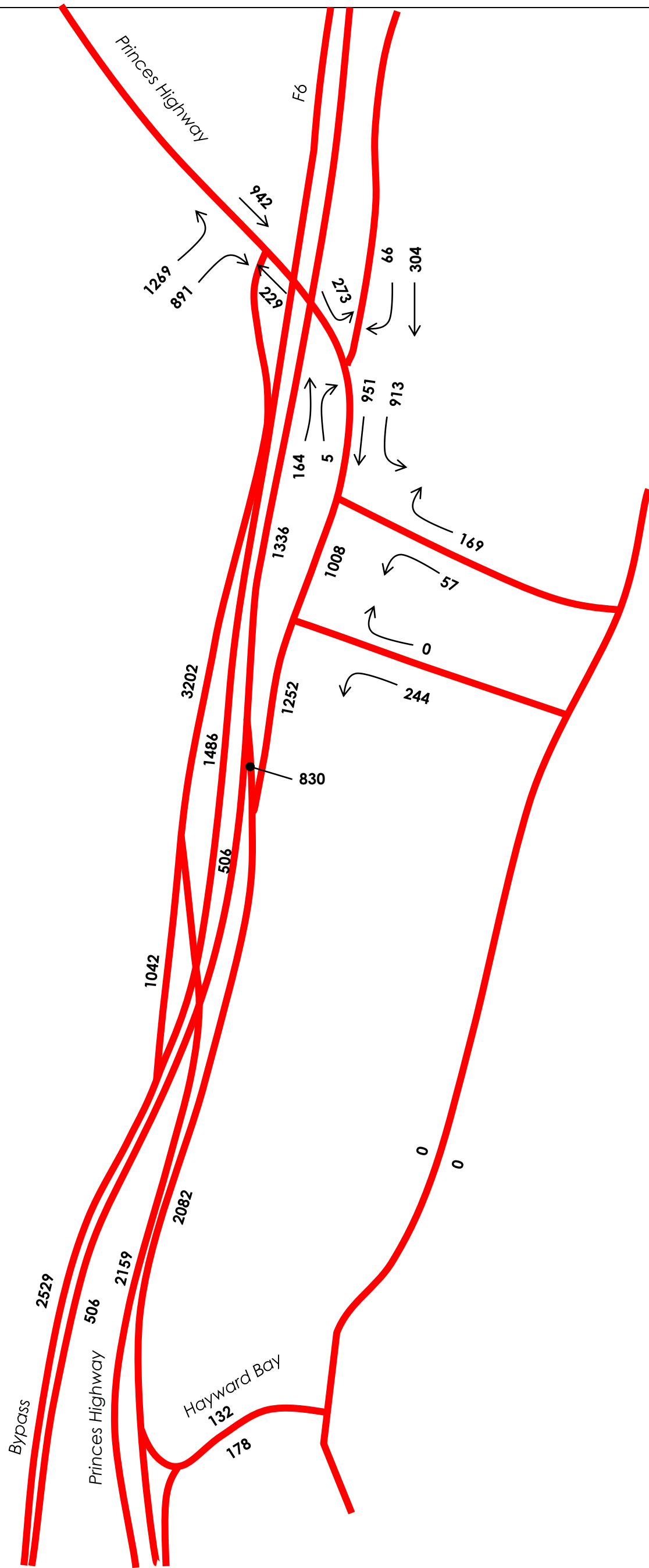

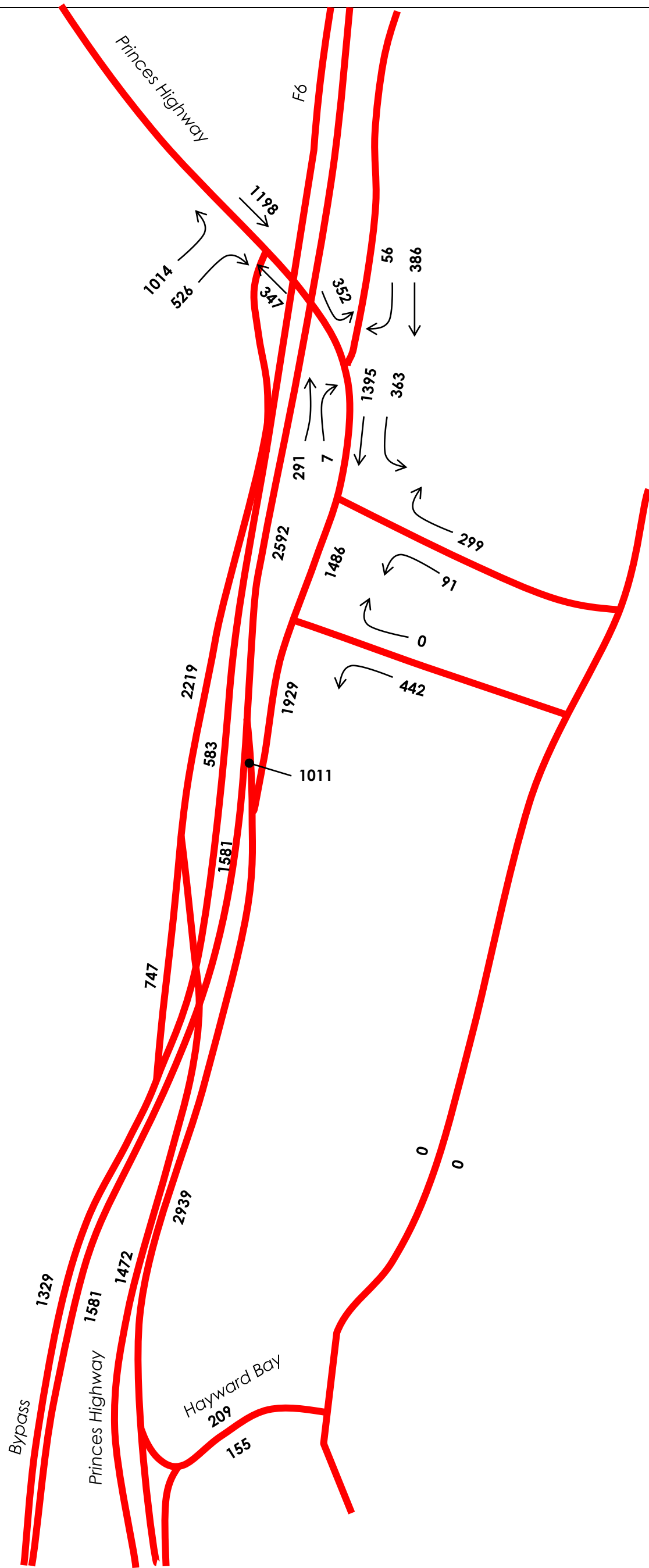

PM Peak – No F6 Ramps, No Hayward’s Bay, with Tallawarra Development

Figure 66

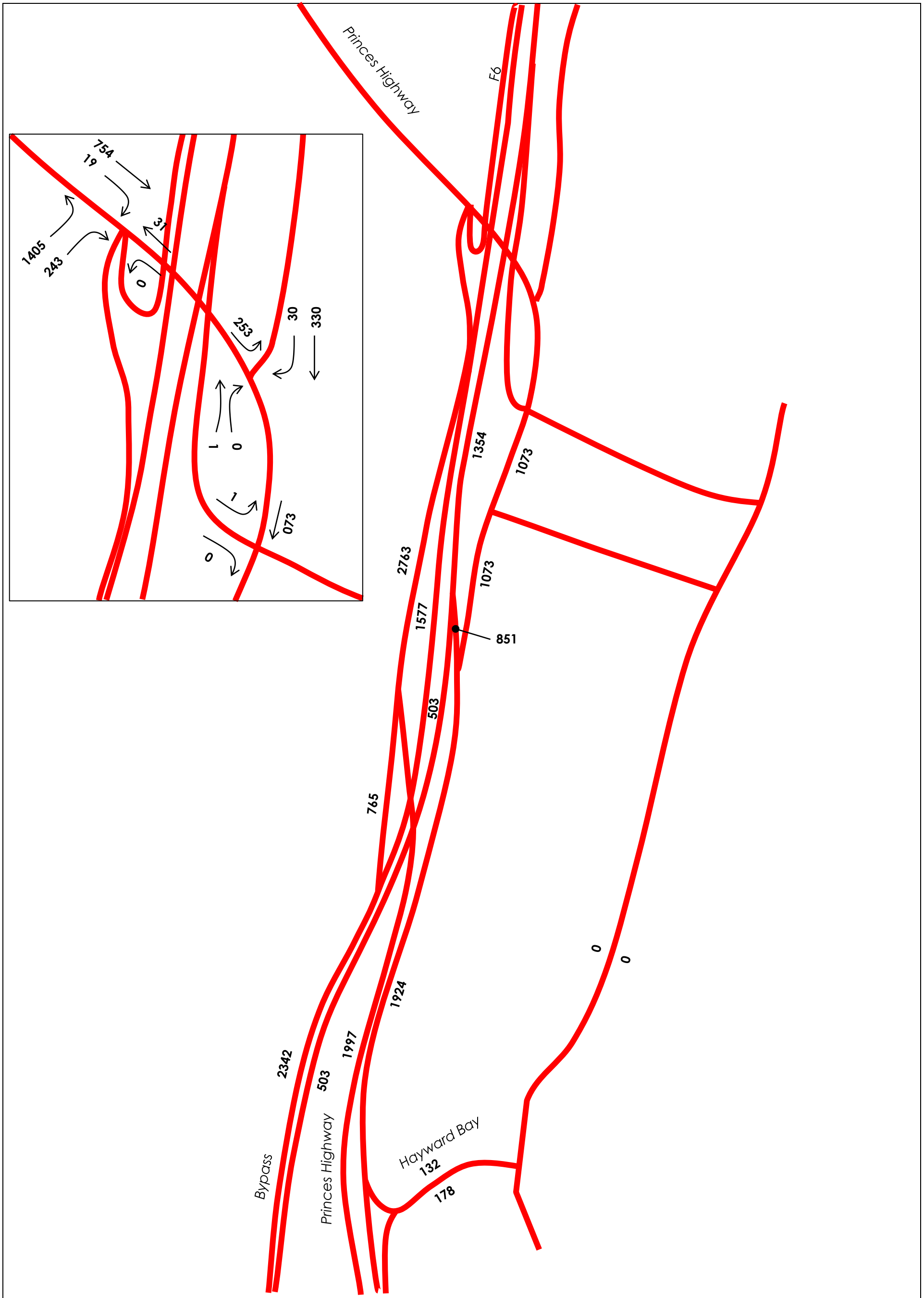

Tallawarra Transportation Model  
 Gabites Porter Consultants

**AM Peak – with F6 Ramps, with Hayward’s Bay, without Tallawarra Development**

**Figure 67**

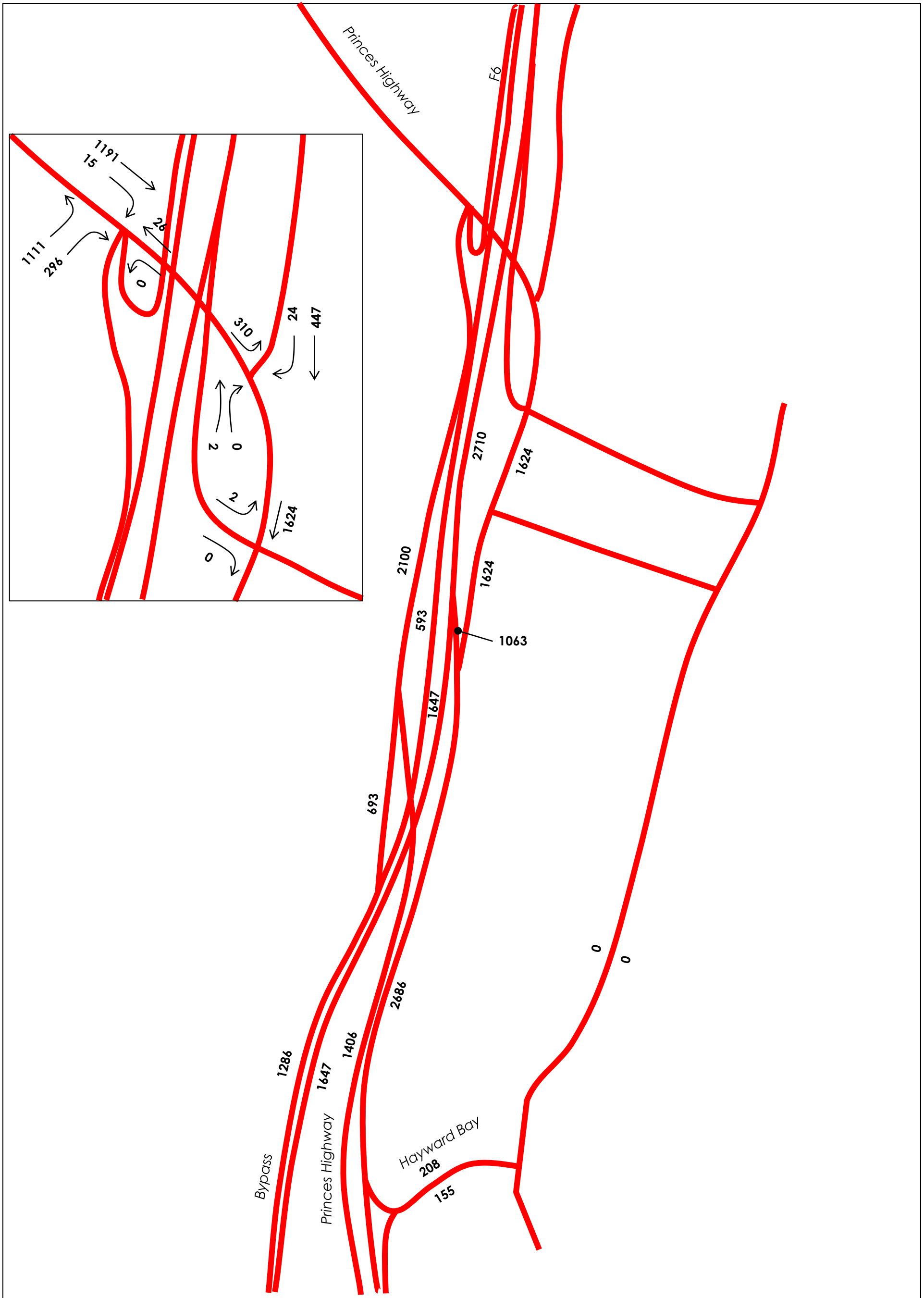

Tallawarra Transportation Model  
 Gabites Porter Consultants

PM Peak – with F6 Ramps, with Hayward’s Bay, without Tallawarra Development

Figure 68

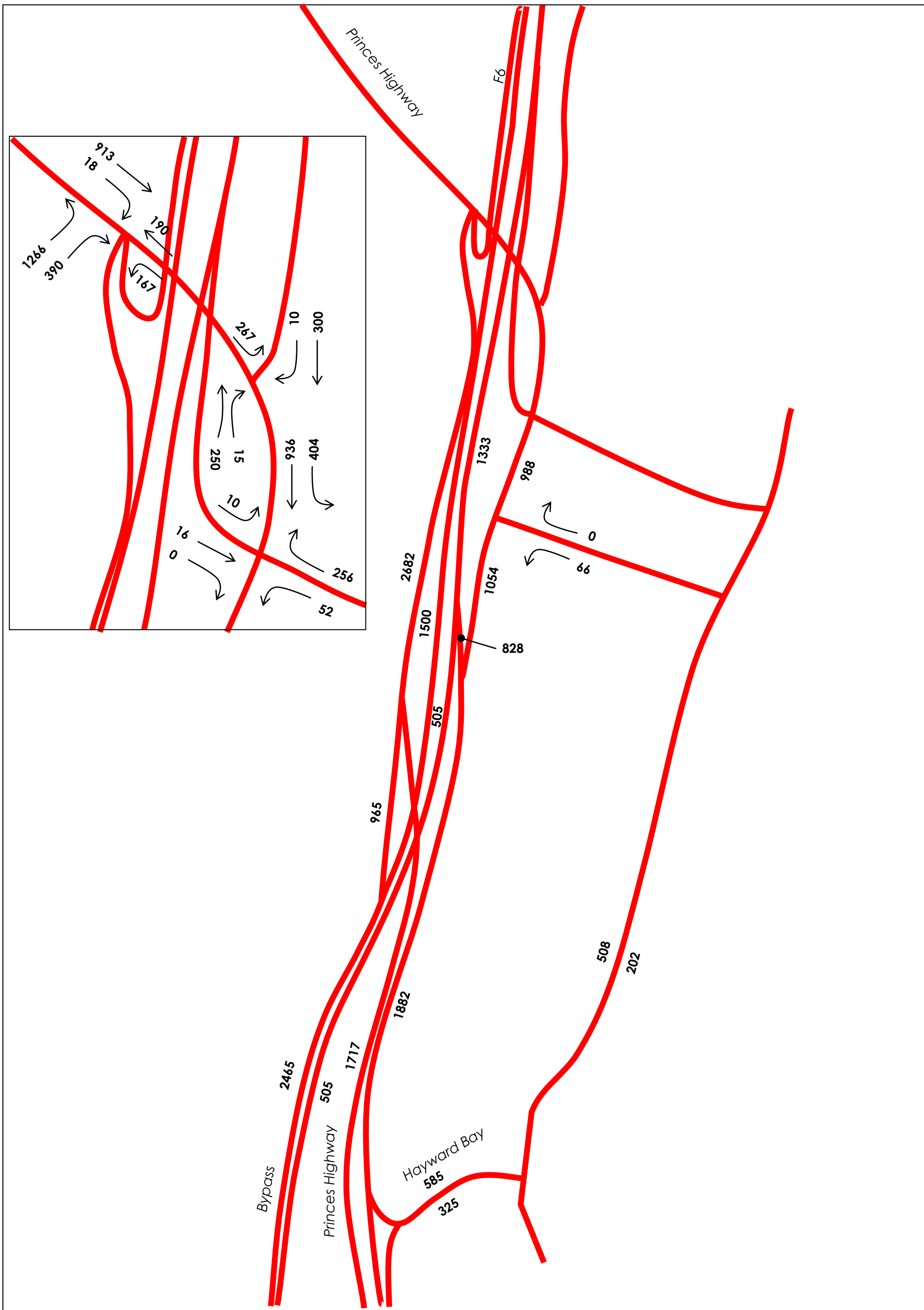

Tallawarra Transportation Model  
 Gabites Porter Consultants

**AM Peak – with F6 Ramps, with Hayward’s Bay, with Tallawarra Development**

**Figure 69**

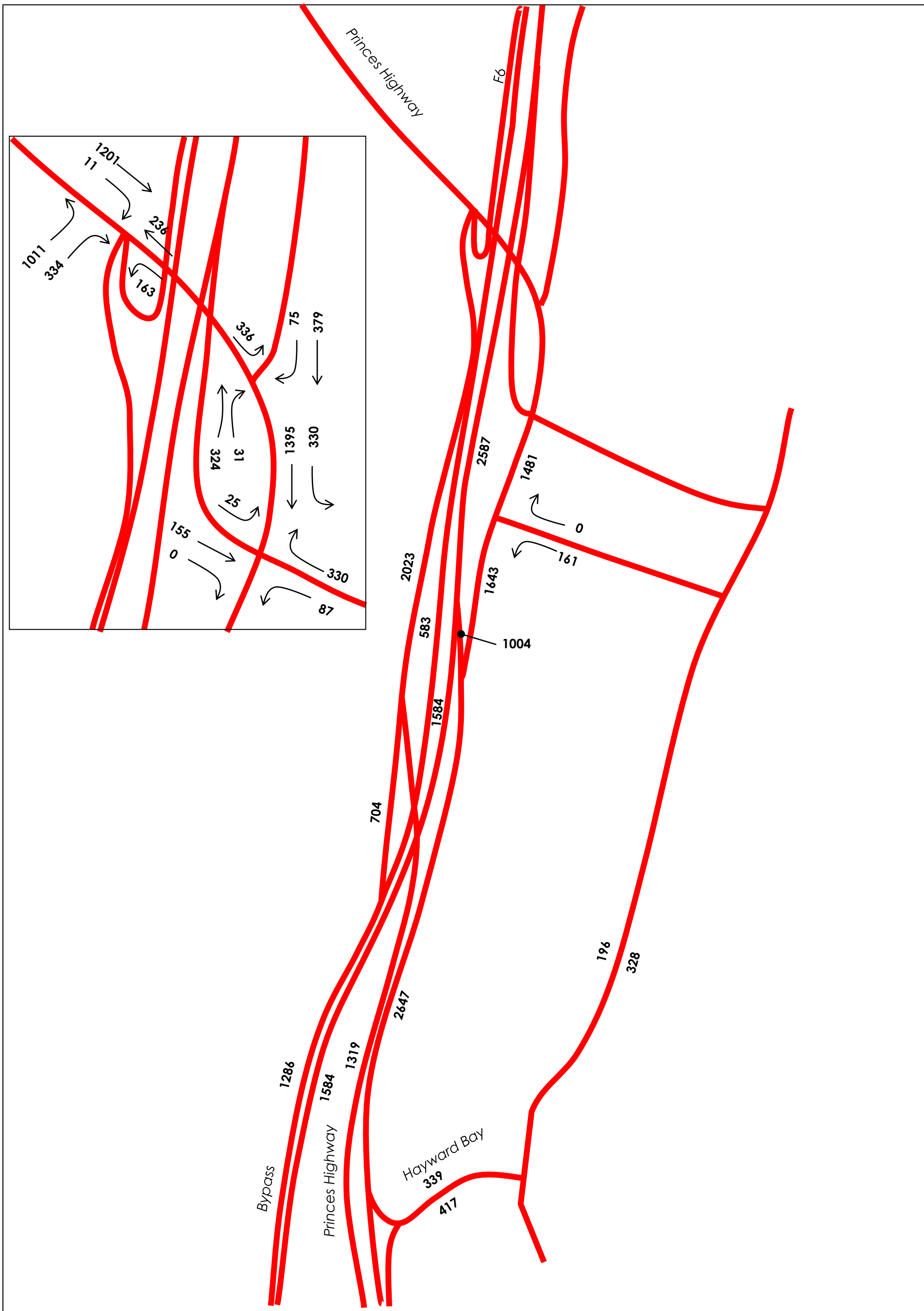

Tallawarra Transportation Model  
 Gabites Porter Consultants

**AM Peak – with F6 Ramps, with Hayward’s Bay, with Tallawarra Development**

**Figure 70**

# Appendix 1

## SIDRA Analyses for Critical Intersections

1. 2036 Highway Intersections without Tallawarra Development - AMP
2. 2036 Highway Intersections without Tallawarra Development - PMP
3. 2036 Highway and Internal Intersections with Tallawarra Development – No Haywards Link - AMP
4. 2036 Highway and Internal Intersections with Tallawarra Development – No Haywards Link - PMP
5. 2036 Highway and Internal Intersections with Tallawarra Development – With Haywards Link - AMP
6. 2036 Highway and Internal Intersections with Tallawarra Development – With Haywards Link - PMP

1. 2036 Highway Intersections without Tallawarra Development - AMP  
**INTERSECTION SUMMARY** Site: 2557- F6 Off Ramp/Princes

Intersection Performance - Hourly Values		
Performance Measure	Vehicles	Persons
Demand Flows (Total)	2561 veh/h	3073 pers/h
Percent Heavy Vehicles	7.0%	
Degree of Saturation	0.878	
Practical Spare Capacity	-3.2%	
Effective Intersection Capacity	2916 veh/h	
Control Delay (Total)	4.66 veh-h/h	5.59 pers-h/h
Control Delay (Average)	6.5 sec	6.5 sec
Control Delay (Worst Lane)	11.5 sec	
Control Delay (Worst Movement)	11.5 sec	11.5 sec
Geometric Delay (Average)	5.9 sec	
Stop-Line Delay (Average)	0.7 sec	
Level of Service (Aver. Int. Delay)	LOS A	
Level of Service (Worst Movement)	LOS A	
Level of Service (Worst Lane)	LOS A	
95% Back of Queue - Vehicles (Worst Lane)	20.4 veh	
95% Back of Queue - Distance (Worst Lane)	151.0 m	
Total Effective Stops	1214 veh/h	1456 pers/h
Effective Stop Rate	0.47 per veh	0.47 per pers
Proportion Queued	0.36	0.36
Performance Index	46.7	46.7
Travel Distance (Total)	1571.7 veh-km/h	1886.1 pers-km/h
Travel Distance (Average)	614 m	614 m
Travel Time (Total)	31.8 veh-h/h	38.2 pers-h/h
Travel Time (Average)	44.7 sec	44.7 sec
Travel Speed	49.4 km/h	49.4 km/h
Cost (Total)	1095.52 \$/h	1095.52 \$/h
Fuel Consumption (Total)	195.5 L/h	
Carbon Dioxide (Total)	490.2 kg/h	
Hydrocarbons (Total)	0.736 kg/h	
Carbon Monoxide (Total)	36.90 kg/h	
NOx (Total)	1.176 kg/h	

LOS (Aver. Int. Delay) for Vehicles is based on average delay for all vehicle movements. LOS Method: Delay (RTA NSW).

LOS Method for individual vehicle movements and lanes: Delay (RTA NSW).

Roundabout Capacity Model: SIDRA Standard.

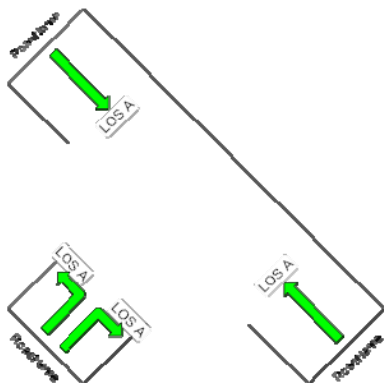

# INTERSECTION SUMMARY

Site: 2469-Princes/Cormack

Intersection Performance - Hourly Values		
Performance Measure	Vehicles	Persons
Demand Flows (Total)	1432veh/h	1718pers/h
Percent Heavy Vehicles	7.0%	
Degree of Saturation	0.322	
Practical Spare Capacity	163.5%	
Effective Intersection Capacity	4439veh/h	
Control Delay (Total)	2.30veh-h/h	2.77pers-h/h
Control Delay (Average)	5.8sec	5.8sec
Control Delay (Worst Lane)	14.6sec	
Control Delay (Worst Movement)	14.6sec	14.6sec
Geometric Delay (Average)	5.2sec	
Stop-Line Delay (Average)	0.6sec	
Level of Service (Aver. Int. Delay)	LOS A	
Level of Service (Worst Movement)	LOS B	
Level of Service (Worst Lane)	LOS B	
95% Back of Queue - Vehicles (Worst Lane)	2.0veh	
95% Back of Queue - Distance (Worst Lane)	15.1m	
Total Effective Stops	699veh/h	839pers/h
Effective Stop Rate	0.49per veh	0.49per pers
Proportion Queued	0.16	0.16
Performance Index	22.7	22.7
Travel Distance (Total)	874.5veh-km/h	1049.4pers-km/h
Travel Distance (Average)	611m	611m
Travel Time (Total)	16.9veh-h/h	20.3pers-h/h
Travel Time (Average)	42.6sec	42.6sec
Travel Speed	51.6km/h	51.6km/h
Cost (Total)	580.25\$/h	580.25\$/h
Fuel Consumption (Total)	102.6L/h	
Carbon Dioxide (Total)	257.3kg/h	
Hydrocarbons (Total)	0.376kg/h	
Carbon Monoxide (Total)	18.09kg/h	
NOx (Total)	0.598kg/h	

LOS (Aver. Int. Delay) for Vehicles is based on average delay for all vehicle movements. LOS Method: Delay (RTA NSW).

LOS Method for individual vehicle movements and lanes: Delay (RTA NSW).

Roundabout Capacity Model: SIDRA Standard.

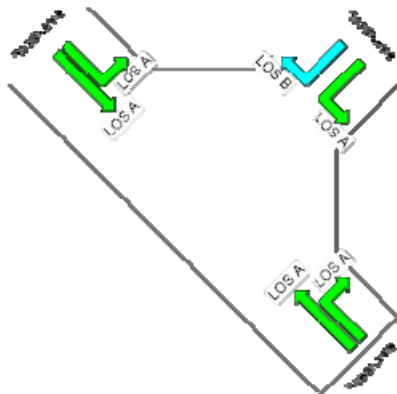

# INTERSECTION SUMMARY

Site: 2467-Princes/Main Entrance

Intersection Performance - Hourly Values		
Performance Measure	Vehicles	Persons
Demand Flows (Total)	1135 veh/h	1362 pers/h
Percent Heavy Vehicles	7.0%	
Degree of Saturation	0.344	
Practical Spare Capacity	142.3%	
Effective Intersection Capacity	3234 veh/h	
Control Delay (Total)	1.41 veh-h/h	1.69 pers-h/h
Control Delay (Average)	4.5 sec	4.5 sec
Control Delay (Worst Lane)	14.0 sec	
Control Delay (Worst Movement)	13.9 sec	13.9 sec
Geometric Delay (Average)	4.5 sec	
Stop-Line Delay (Average)	0.0 sec	
Level of Service (Aver. Int. Delay)	LOS A	
Level of Service (Worst Movement)	LOS A	
Level of Service (Worst Lane)	LOS A	
95% Back of Queue - Vehicles (Worst Lane)	0.0 veh	
95% Back of Queue - Distance (Worst Lane)	0.0 m	
Total Effective Stops	447 veh/h	536 pers/h
Effective Stop Rate	0.39 per veh	0.39 per pers
Proportion Queued	0.00	0.00
Performance Index	15.5	15.5
Travel Distance (Total)	694.5 veh-km/h	833.4 pers-km/h
Travel Distance (Average)	612 m	612 m
Travel Time (Total)	12.9 veh-h/h	15.5 pers-h/h
Travel Time (Average)	41.1 sec	41.1 sec
Travel Speed	53.6 km/h	53.6 km/h
Cost (Total)	439.88 \$/h	439.88 \$/h
Fuel Consumption (Total)	76.6 L/h	
Carbon Dioxide (Total)	192.1 kg/h	
Hydrocarbons (Total)	0.272 kg/h	
Carbon Monoxide (Total)	12.43 kg/h	
NOx (Total)	0.431 kg/h	

LOS (Aver. Int. Delay) for Vehicles is based on average delay for all vehicle movements. LOS Method: Delay (RTA NSW).

LOS Method for individual vehicle movements and lanes: Delay (RTA NSW).

Roundabout Capacity Model: SIDRA Standard.

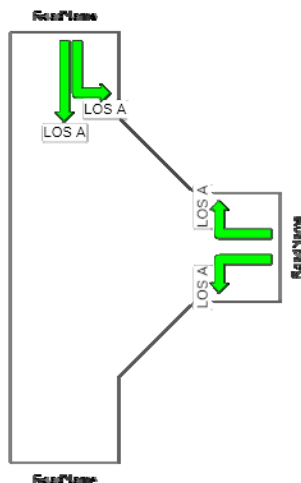

# INTERSECTION SUMMARY

Site: 4358-Princes/South Entrance

Intersection Performance - Hourly Values		
Performance Measure	Vehicles	Persons
Demand Flows (Total)	1135 veh/h	1362 pers/h
Percent Heavy Vehicles	7.0%	
Degree of Saturation	0.344	
Practical Spare Capacity	142.3%	
Effective Intersection Capacity	3234 veh/h	
Control Delay (Total)	1.41 veh-h/h	1.69 pers-h/h
Control Delay (Average)	4.5 sec	4.5 sec
Control Delay (Worst Lane)	14.0 sec	
Control Delay (Worst Movement)	13.9 sec	13.9 sec
Geometric Delay (Average)	4.5 sec	
Stop-Line Delay (Average)	0.0 sec	
Level of Service (Aver. Int. Delay)	LOS A	
Level of Service (Worst Movement)	LOS A	
Level of Service (Worst Lane)	LOS A	
95% Back of Queue - Vehicles (Worst Lane)	0.0 veh	
95% Back of Queue - Distance (Worst Lane)	0.0 m	
Total Effective Stops	447 veh/h	536 pers/h
Effective Stop Rate	0.39 per veh	0.39 per pers
Proportion Queued	0.00	0.00
Performance Index	15.5	15.5
Travel Distance (Total)	694.5 veh-km/h	833.4 pers-km/h
Travel Distance (Average)	612 m	612 m
Travel Time (Total)	12.9 veh-h/h	15.5 pers-h/h
Travel Time (Average)	41.1 sec	41.1 sec
Travel Speed	53.6 km/h	53.6 km/h
Cost (Total)	439.88 \$/h	439.88 \$/h
Fuel Consumption (Total)	76.6 L/h	
Carbon Dioxide (Total)	192.1 kg/h	
Hydrocarbons (Total)	0.272 kg/h	
Carbon Monoxide (Total)	12.43 kg/h	
NOx (Total)	0.431 kg/h	

LOS (Aver. Int. Delay) for Vehicles is based on average delay for all vehicle movements. LOS Method: Delay (RTA NSW).

LOS Method for individual vehicle movements and lanes: Delay (RTA NSW).

Roundabout Capacity Model: SIDRA Standard.

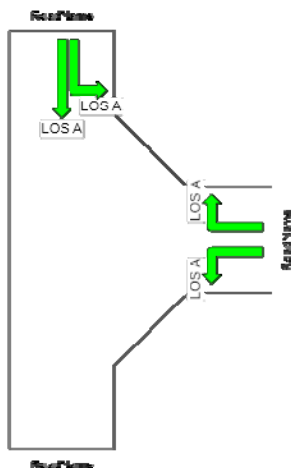

# INTERSECTION SUMMARY

Site: 2833-F6 Off Ramp/Haywards

Intersection Performance - Hourly Values		
Performance Measure	Vehicles	Persons
Demand Flows (Total)	671 veh/h	805 pers/h
Percent Heavy Vehicles	7.0%	
Degree of Saturation	0.135	
Practical Spare Capacity	527.3%	
Effective Intersection Capacity	4948 veh/h	
Control Delay (Total)	1.65 veh-h/h	1.98 pers-h/h
Control Delay (Average)	8.8 sec	8.8 sec
Control Delay (Worst Lane)	12.0 sec	
Control Delay (Worst Movement)	12.0 sec	12.0 sec
Geometric Delay (Average)	8.2 sec	
Stop-Line Delay (Average)	0.6 sec	
Level of Service (Aver. Int. Delay)	LOS A	
Level of Service (Worst Movement)	LOS A	
Level of Service (Worst Lane)	LOS A	
95% Back of Queue - Vehicles (Worst Lane)	0.7 veh	
95% Back of Queue - Distance (Worst Lane)	4.9 m	
Total Effective Stops	396 veh/h	475 pers/h
Effective Stop Rate	0.59 per veh	0.59 per pers
Proportion Queued	0.23	0.23
Performance Index	11.5	11.5
Travel Distance (Total)	425.7 veh-km/h	510.9 pers-km/h
Travel Distance (Average)	635 m	635 m
Travel Time (Total)	8.8 veh-h/h	10.6 pers-h/h
Travel Time (Average)	47.5 sec	47.5 sec
Travel Speed	48.1 km/h	48.1 km/h
Cost (Total)	301.00 \$/h	301.00 \$/h
Fuel Consumption (Total)	52.7 L/h	
Carbon Dioxide (Total)	132.1 kg/h	
Hydrocarbons (Total)	0.199 kg/h	
Carbon Monoxide (Total)	9.88 kg/h	
NOx (Total)	0.313 kg/h	

LOS (Aver. Int. Delay) for Vehicles is based on average delay for all vehicle movements. LOS Method: Delay (RTA NSW).

LOS Method for individual vehicle movements and lanes: Delay (RTA NSW).

Roundabout Capacity Model: SIDRA Standard.

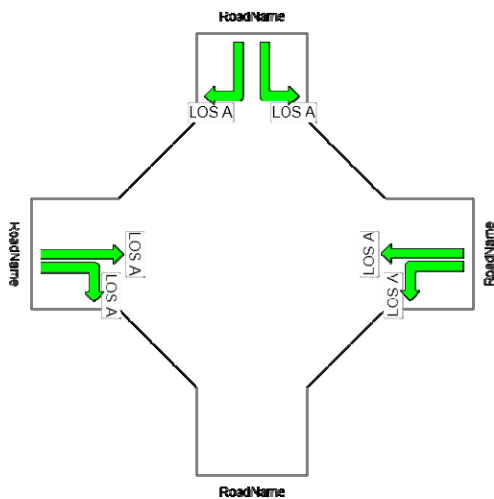

# INTERSECTION SUMMARY

Site: 2813-Haywards/Yallah Rd

Intersection Performance - Hourly Values		
Performance Measure	Vehicles	Persons
Demand Flows (Total)	776veh/h	931pers/h
Percent Heavy Vehicles	7.0%	
Degree of Saturation	0.173	
Practical Spare Capacity	390.0%	
Effective Intersection Capacity	4473veh/h	
Control Delay (Total)	1.81veh-h/h	2.18pers-h/h
Control Delay (Average)	8.4sec	8.4sec
Control Delay (Worst Lane)	11.3sec	
Control Delay (Worst Movement)	12.5sec	12.5sec
Geometric Delay (Average)	8.0sec	
Stop-Line Delay (Average)	0.4sec	
Level of Service (Aver. Int. Delay)	LOS A	
Level of Service (Worst Movement)	LOS A	
Level of Service (Worst Lane)	LOS A	
95% Back of Queue - Vehicles (Worst Lane)	1.0veh	
95% Back of Queue - Distance (Worst Lane)	7.2m	
Total Effective Stops	450veh/h	540pers/h
Effective Stop Rate	0.58per veh	0.58per pers
Proportion Queued	0.18	0.18
Performance Index	13.5	13.5
Travel Distance (Total)	490.8veh-km/h	588.9pers-km/h
Travel Distance (Average)	633m	633m
Travel Time (Total)	10.1veh-h/h	12.1pers-h/h
Travel Time (Average)	46.9sec	46.9sec
Travel Speed	48.6km/h	48.6km/h
Cost (Total)	344.16\$/h	344.16\$/h
Fuel Consumption (Total)	60.4L/h	
Carbon Dioxide (Total)	151.5kg/h	
Hydrocarbons (Total)	0.228kg/h	
Carbon Monoxide (Total)	11.30kg/h	
NOx (Total)	0.358kg/h	

LOS (Aver. Int. Delay) for Vehicles is based on average delay for all vehicle movements. LOS Method: Delay (RTA NSW).

LOS Method for individual vehicle movements and lanes: Delay (RTA NSW).

Roundabout Capacity Model: SIDRA Standard.

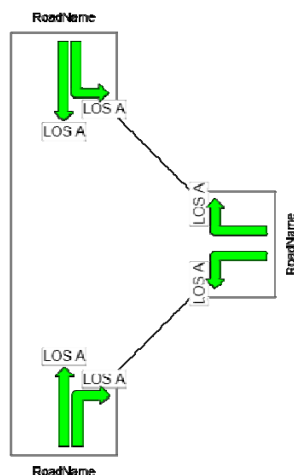

## 2. 2036 Highway Intersections without Tallawarra Development – PMP

### INTERSECTION SUMMARY

Site: 2557- F6 Off Ramp/Princes

Intersection Performance - Hourly Values		
Performance Measure	Vehicles	Persons
Demand Flows (Total)	2764 veh/h	3317 pers/h
Percent Heavy Vehicles	7.0%	
Degree of Saturation	0.692	
Practical Spare Capacity	22.8%	
Effective Intersection Capacity	3995 veh/h	
Control Delay (Total)	5.14 veh-h/h	6.17 pers-h/h
Control Delay (Average)	6.7 sec	6.7 sec
Control Delay (Worst Lane)	11.5 sec	
Control Delay (Worst Movement)	11.5 sec	11.5 sec
Geometric Delay (Average)	5.8 sec	
Stop-Line Delay (Average)	0.9 sec	
Level of Service (Aver. Int. Delay)	LOS A	
Level of Service (Worst Movement)	LOS A	
Level of Service (Worst Lane)	LOS A	
95% Back of Queue - Vehicles (Worst Lane)	7.6 veh	
95% Back of Queue - Distance (Worst Lane)	56.1 m	
Total Effective Stops	1450 veh/h	1740 pers/h
Effective Stop Rate	0.52 per veh	0.52 per pers
Proportion Queued	0.34	0.34
Performance Index	47.4	47.4
Travel Distance (Total)	1700.2 veh-km/h	2040.3 pers-km/h
Travel Distance (Average)	615 m	615 m
Travel Time (Total)	34.3 veh-h/h	41.2 pers-h/h
Travel Time (Average)	44.7 sec	44.7 sec
Travel Speed	49.5 km/h	49.5 km/h
Cost (Total)	1180.87 \$/h	1180.87 \$/h
Fuel Consumption (Total)	210.5 L/h	
Carbon Dioxide (Total)	527.8 kg/h	
Hydrocarbons (Total)	0.791 kg/h	
Carbon Monoxide (Total)	39.54 kg/h	
NOx (Total)	1.263 kg/h	

LOS (Aver. Int. Delay) for Vehicles is based on average delay for all vehicle movements. LOS Method: Delay (RTA NSW).

LOS Method for individual vehicle movements and lanes: Delay (RTA NSW).

Roundabout Capacity Model: SIDRA Standard.

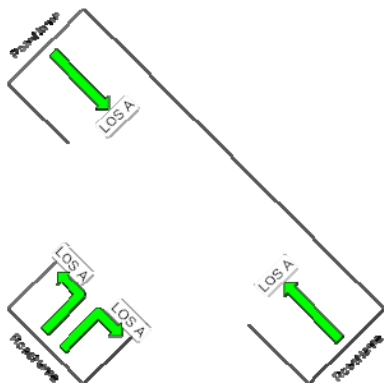

# INTERSECTION SUMMARY

Site: 2469-Princes/Cormack

Intersection Performance - Hourly Values		
Performance Measure	Vehicles	Persons
Demand Flows (Total)	2069veh/h	2483pers/h
Percent Heavy Vehicles	7.0%	
Degree of Saturation	0.492	
Practical Spare Capacity	72.7%	
Effective Intersection Capacity	4204veh/h	
Control Delay (Total)	3.56veh-h/h	4.27pers-h/h
Control Delay (Average)	6.2sec	6.2sec
Control Delay (Worst Lane)	15.8sec	
Control Delay (Worst Movement)	15.8sec	15.8sec
Geometric Delay (Average)	5.0sec	
Stop-Line Delay (Average)	1.2sec	
Level of Service (Aver. Int. Delay)	LOS A	
Level of Service (Worst Movement)	LOS B	
Level of Service (Worst Lane)	LOS B	
95% Back of Queue - Vehicles (Worst Lane)	3.8veh	
95% Back of Queue - Distance (Worst Lane)	27.9m	
Total Effective Stops	1094veh/h	1312pers/h
Effective Stop Rate	0.53per veh	0.53per pers
Proportion Queued	0.18	0.18
Performance Index	34.4	34.4
Travel Distance (Total)	1263.6veh-km/h	1516.4pers-km/h
Travel Distance (Average)	611m	611m
Travel Time (Total)	24.6veh-h/h	29.5pers-h/h
Travel Time (Average)	42.8sec	42.8sec
Travel Speed	51.4km/h	51.4km/h
Cost (Total)	841.79\$/h	841.79\$/h
Fuel Consumption (Total)	148.5L/h	
Carbon Dioxide (Total)	372.4kg/h	
Hydrocarbons (Total)	0.544kg/h	
Carbon Monoxide (Total)	26.18kg/h	
NOx (Total)	0.866kg/h	

LOS (Aver. Int. Delay) for Vehicles is based on average delay for all vehicle movements. LOS Method: Delay (RTA NSW).

LOS Method for individual vehicle movements and lanes: Delay (RTA NSW).

Roundabout Capacity Model: SIDRA Standard.

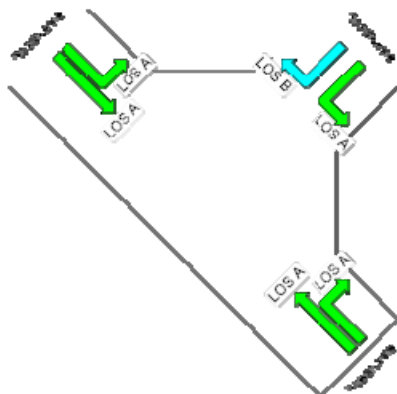

# INTERSECTION SUMMARY

Site: 2467-Princes/Main Entrance

Intersection Performance - Hourly Values		
Performance Measure	Vehicles	Persons
Demand Flows (Total)	1718veh/h	2061pers/h
Percent Heavy Vehicles	7.0%	
Degree of Saturation	0.521	
Practical Spare Capacity	61.5%	
Effective Intersection Capacity	3264veh/h	
Control Delay (Total)	2.14veh-h/h	2.56pers-h/h
Control Delay (Average)	4.5sec	4.5sec
Control Delay (Worst Lane)	16.2sec	
Control Delay (Worst Movement)	15.9sec	15.9sec
Geometric Delay (Average)	4.5sec	
Stop-Line Delay (Average)	0.0sec	
Level of Service (Aver. Int. Delay)	LOS A	
Level of Service (Worst Movement)	LOS B	
Level of Service (Worst Lane)	LOS B	
95% Back of Queue - Vehicles (Worst Lane)	0.0veh	
95% Back of Queue - Distance (Worst Lane)	0.1m	
Total Effective Stops	676veh/h	811pers/h
Effective Stop Rate	0.39per veh	0.39per pers
Proportion Queued	0.00	0.00
Performance Index	23.4	23.4
Travel Distance (Total)	1051.3veh-km/h	1261.6pers-km/h
Travel Distance (Average)	612m	612m
Travel Time (Total)	19.6veh-h/h	23.5pers-h/h
Travel Time (Average)	41.1sec	41.1sec
Travel Speed	53.6km/h	53.6km/h
Cost (Total)	665.92\$/h	665.92\$/h
Fuel Consumption (Total)	116.0L/h	
Carbon Dioxide (Total)	290.9kg/h	
Hydrocarbons (Total)	0.412kg/h	
Carbon Monoxide (Total)	18.81kg/h	
NOx (Total)	0.652kg/h	

LOS (Aver. Int. Delay) for Vehicles is based on average delay for all vehicle movements. LOS Method: Delay (RTA NSW).

LOS Method for individual vehicle movements and lanes: Delay (RTA NSW).

Roundabout Capacity Model: SIDRA Standard.

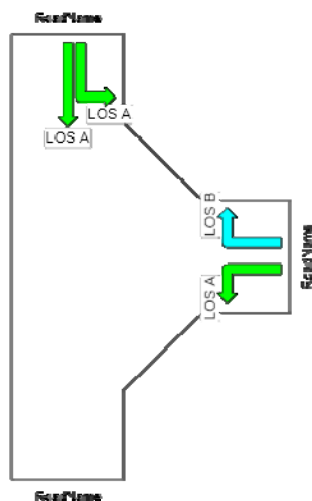

# INTERSECTION SUMMARY

Site: 4358-Princes/South Entrance

Intersection Performance - Hourly Values		
Performance Measure	Vehicles	Persons
Demand Flows (Total)	1718veh/h	2061pers/h
Percent Heavy Vehicles	7.0%	
Degree of Saturation	0.521	
Practical Spare Capacity	61.5%	
Effective Intersection Capacity	3264veh/h	
Control Delay (Total)	2.14veh-h/h	2.56pers-h/h
Control Delay (Average)	4.5sec	4.5sec
Control Delay (Worst Lane)	16.2sec	
Control Delay (Worst Movement)	15.9sec	15.9sec
Geometric Delay (Average)	4.5sec	
Stop-Line Delay (Average)	0.0sec	
Level of Service (Aver. Int. Delay)	LOS A	
Level of Service (Worst Movement)	LOS B	
Level of Service (Worst Lane)	LOS B	
95% Back of Queue - Vehicles (Worst Lane)	0.0veh	
95% Back of Queue - Distance (Worst Lane)	0.1m	
Total Effective Stops	676veh/h	811pers/h
Effective Stop Rate	0.39per veh	0.39per pers
Proportion Queued	0.00	0.00
Performance Index	23.4	23.4
Travel Distance (Total)	1051.3veh-km/h	1261.6pers-km/h
Travel Distance (Average)	612m	612m
Travel Time (Total)	19.6veh-h/h	23.5pers-h/h
Travel Time (Average)	41.1sec	41.1sec
Travel Speed	53.6km/h	53.6km/h
Cost (Total)	665.92\$/h	665.92\$/h
Fuel Consumption (Total)	116.0L/h	
Carbon Dioxide (Total)	290.9kg/h	
Hydrocarbons (Total)	0.412kg/h	
Carbon Monoxide (Total)	18.81kg/h	
NOx (Total)	0.652kg/h	

LOS (Aver. Int. Delay) for Vehicles is based on average delay for all vehicle movements. LOS Method: Delay (RTA NSW).

LOS Method for individual vehicle movements and lanes: Delay (RTA NSW).

Roundabout Capacity Model: SIDRA Standard.

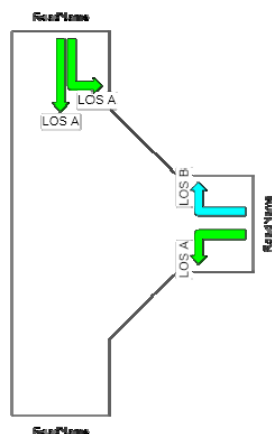

# INTERSECTION SUMMARY

Site: 2833-F6 Off Ramp/Haywards

Intersection Performance - Hourly Values		
Performance Measure	Vehicles	Persons
Demand Flows (Total)	906veh/h	1088pers/h
Percent Heavy Vehicles	7.0%	
Degree of Saturation	0.225	
Practical Spare Capacity	277.2%	
Effective Intersection Capacity	4022veh/h	
Control Delay (Total)	2.42veh-h/h	2.90pers-h/h
Control Delay (Average)	9.6sec	9.6sec
Control Delay (Worst Lane)	12.4sec	
Control Delay (Worst Movement)	12.4sec	12.4sec
Geometric Delay (Average)	8.7sec	
Stop-Line Delay (Average)	0.9sec	
Level of Service (Aver. Int. Delay)	LOS A	
Level of Service (Worst Movement)	LOS A	
Level of Service (Worst Lane)	LOS A	
95% Back of Queue - Vehicles (Worst Lane)	1.2veh	
95% Back of Queue - Distance (Worst Lane)	8.8m	
Total Effective Stops	573veh/h	688pers/h
Effective Stop Rate	0.63per veh	0.63per pers
Proportion Queued	0.27	0.27
Performance Index	16.1	16.1
Travel Distance (Total)	578.0veh-km/h	693.7pers-km/h
Travel Distance (Average)	638m	638m
Travel Time (Total)	12.2veh-h/h	14.6pers-h/h
Travel Time (Average)	48.3sec	48.3sec
Travel Speed	47.5km/h	47.5km/h
Cost (Total)	413.85\$/h	413.85\$/h
Fuel Consumption (Total)	72.4L/h	
Carbon Dioxide (Total)	181.5kg/h	
Hydrocarbons (Total)	0.276kg/h	
Carbon Monoxide (Total)	13.74kg/h	
NOx (Total)	0.431kg/h	

LOS (Aver. Int. Delay) for Vehicles is based on average delay for all vehicle movements. LOS Method: Delay (RTA NSW).

LOS Method for individual vehicle movements and lanes: Delay (RTA NSW).

Roundabout Capacity Model: SIDRA Standard.

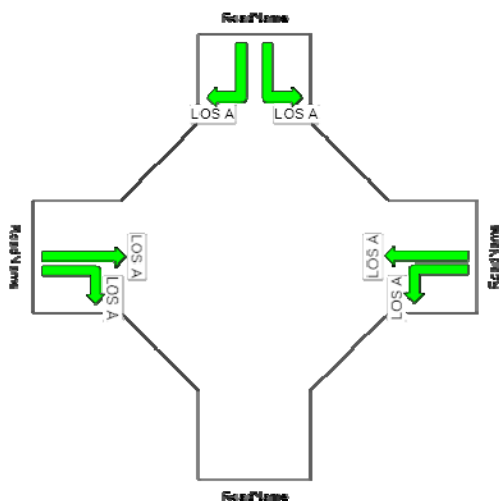

# INTERSECTION SUMMARY

Site: 2813-Haywards/Yallah Rd

Intersection Performance - Hourly Values		
Performance Measure	Vehicles	Persons
Demand Flows (Total)	887veh/h	1065pers/h
Percent Heavy Vehicles	7.0%	
Degree of Saturation	0.213	
Practical Spare Capacity	298.8%	
Effective Intersection Capacity	4163veh/h	
Control Delay (Total)	2.15veh-h/h	2.58pers-h/h
Control Delay (Average)	8.7sec	8.7sec
Control Delay (Worst Lane)	11.3sec	
Control Delay (Worst Movement)	12.8sec	12.8sec
Geometric Delay (Average)	8.3sec	
Stop-Line Delay (Average)	0.5sec	
Level of Service (Aver. Int. Delay)	LOS A	
Level of Service (Worst Movement)	LOS A	
Level of Service (Worst Lane)	LOS A	
95% Back of Queue - Vehicles (Worst Lane)	1.3veh	
95% Back of Queue - Distance (Worst Lane)	9.3m	
Total Effective Stops	524veh/h	629pers/h
Effective Stop Rate	0.59per veh	0.59per pers
Proportion Queued	0.18	0.18
Performance Index	15.6	15.6
Travel Distance (Total)	562.5veh-km/h	675.0pers-km/h
Travel Distance (Average)	634m	634m
Travel Time (Total)	11.6veh-h/h	14.0pers-h/h
Travel Time (Average)	47.2sec	47.2sec
Travel Speed	48.4km/h	48.4km/h
Cost (Total)	396.56\$/h	396.56\$/h
Fuel Consumption (Total)	69.7L/h	
Carbon Dioxide (Total)	174.7kg/h	
Hydrocarbons (Total)	0.264kg/h	
Carbon Monoxide (Total)	13.11kg/h	
NOx (Total)	0.414kg/h	

LOS (Aver. Int. Delay) for Vehicles is based on average delay for all vehicle movements. LOS Method: Delay (RTA NSW).

LOS Method for individual vehicle movements and lanes: Delay (RTA NSW).

Roundabout Capacity Model: SIDRA Standard.

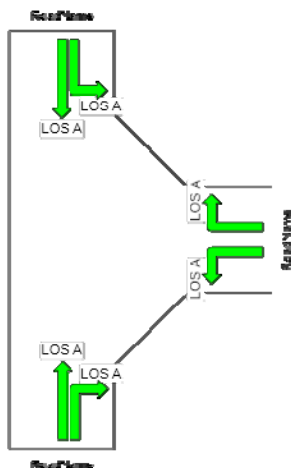

### 3. 2036 Highway/Internal Intersections with Tallawarra–No Haywards Link-AMP **INTERSECTION SUMMARY**

Site: 2557- F6 Off Ramp/Princes

Intersection Performance - Hourly Values		
Performance Measure	Vehicles	Persons
Demand Flows (Total)	3506veh/h	4208pers/h
Percent Heavy Vehicles	7.0%	
Degree of Saturation	0.966	
Practical Spare Capacity	-12.0%	
Effective Intersection Capacity	3630veh/h	
Control Delay (Total)	21.39veh-h/h	25.67pers-h/h
Control Delay (Average)	22.0sec	22.0sec
Control Delay (Worst Lane)	40.4sec	
Control Delay (Worst Movement)	38.8sec	38.8sec
Geometric Delay (Average)	6.8sec	
Stop-Line Delay (Average)	15.2sec	
Level of Service (Aver. Int. Delay)	LOS B	
Level of Service (Worst Movement)	LOS C	
Level of Service (Worst Lane)	LOS C	
95% Back of Queue - Vehicles (Worst Lane)	31.5veh	
95% Back of Queue - Distance (Worst Lane)	233.9m	
Total Effective Stops	3826veh/h	4591pers/h
Effective Stop Rate	1.09per veh	1.09per pers
Proportion Queued	0.86	0.86
Performance Index	108.3	108.3
Travel Distance (Total)	2182.8veh-km/h	2619.4pers-km/h
Travel Distance (Average)	623m	623m
Travel Time (Total)	57.6veh-h/h	69.2pers-h/h
Travel Time (Average)	59.2sec	59.2sec
Travel Speed	37.9km/h	37.9km/h
Cost (Total)	1930.95\$/h	1930.95\$/h
Fuel Consumption (Total)	317.4L/h	
Carbon Dioxide (Total)	795.8kg/h	
Hydrocarbons (Total)	1.276kg/h	
Carbon Monoxide (Total)	64.64kg/h	
NOx (Total)	1.943kg/h	

LOS (Aver. Int. Delay) for Vehicles is based on average delay for all vehicle movements. LOS Method: Delay (RTA NSW).

LOS Method for individual vehicle movements and lanes: Delay (RTA NSW).

Roundabout Capacity Model: SIDRA Standard.

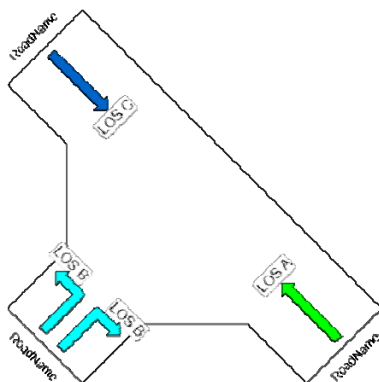

# INTERSECTION SUMMARY

Site: 2469-Princes/Cormack

Intersection Performance - Hourly Values		
Performance Measure	Vehicles	Persons
Demand Flows (Total)	2547veh/h	3057pers/h
Percent Heavy Vehicles	7.0%	
Degree of Saturation	0.615	
Practical Spare Capacity	38.0%	
Effective Intersection Capacity	4137veh/h	
Control Delay (Total)	4.32veh-h/h	5.18pers-h/h
Control Delay (Average)	6.1sec	6.1sec
Control Delay (Worst Lane)	17.0sec	
Control Delay (Worst Movement)	17.0sec	17.0sec
Geometric Delay (Average)	5.0sec	
Stop-Line Delay (Average)	1.1sec	
Level of Service (Aver. Int. Delay)	LOS A	
Level of Service (Worst Movement)	LOS B	
Level of Service (Worst Lane)	LOS B	
95% Back of Queue - Vehicles (Worst Lane)	6.3veh	
95% Back of Queue - Distance (Worst Lane)	46.6m	
Total Effective Stops	1234veh/h	1481pers/h
Effective Stop Rate	0.48per veh	0.48per pers
Proportion Queued	0.28	0.28
Performance Index	42.8	42.8
Travel Distance (Total)	1560.0veh-km/h	1872.0pers-km/h
Travel Distance (Average)	612m	612m
Travel Time (Total)	30.8veh-h/h	37.0pers-h/h
Travel Time (Average)	43.5sec	43.5sec
Travel Speed	50.6km/h	50.6km/h
Cost (Total)	1054.43\$/h	1054.43\$/h
Fuel Consumption (Total)	186.0L/h	
Carbon Dioxide (Total)	466.3kg/h	
Hydrocarbons (Total)	0.686kg/h	
Carbon Monoxide (Total)	33.28kg/h	
NOx (Total)	1.092kg/h	

LOS (Aver. Int. Delay) for Vehicles is based on average delay for all vehicle movements. LOS Method: Delay (RTA NSW).

LOS Method for individual vehicle movements and lanes: Delay (RTA NSW).

Roundabout Capacity Model: SIDRA Standard.

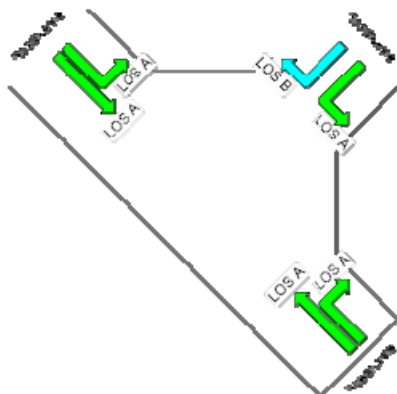

# INTERSECTION SUMMARY

Site: 2467-Princes/Main Entrance

Intersection Performance - Hourly Values		
Performance Measure	Vehicles	Persons
Demand Flows (Total)	2282 veh/h	2739 pers/h
Percent Heavy Vehicles	7.0%	
Degree of Saturation	0.606	
Practical Spare Capacity	40.2%	
Effective Intersection Capacity	3765 veh/h	
Control Delay (Total)	3.74 veh-h/h	4.49 pers-h/h
Control Delay (Average)	5.9 sec	5.9 sec
Control Delay (Worst Lane)	16.6 sec	
Control Delay (Worst Movement)	16.6 sec	16.6 sec
Geometric Delay (Average)	5.3 sec	
Stop-Line Delay (Average)	0.6 sec	
Level of Service (Aver. Int. Delay)	LOS A	
Level of Service (Worst Movement)	LOS B	
Level of Service (Worst Lane)	LOS B	
95% Back of Queue - Vehicles (Worst Lane)	1.1 veh	
95% Back of Queue - Distance (Worst Lane)	7.9 m	
Total Effective Stops	1095 veh/h	1313 pers/h
Effective Stop Rate	0.48 per veh	0.48 per pers
Proportion Queued	0.08	0.08
Performance Index	33.8	33.8
Travel Distance (Total)	1398.3 veh-km/h	1678.0 pers-km/h
Travel Distance (Average)	613 m	613 m
Travel Time (Total)	27.0 veh-h/h	32.4 pers-h/h
Travel Time (Average)	42.5 sec	42.5 sec
Travel Speed	51.9 km/h	51.9 km/h
Cost (Total)	920.46 \$/h	920.46 \$/h
Fuel Consumption (Total)	161.9 L/h	
Carbon Dioxide (Total)	406.0 kg/h	
Hydrocarbons (Total)	0.590 kg/h	
Carbon Monoxide (Total)	28.05 kg/h	
NOx (Total)	0.935 kg/h	

LOS (Aver. Int. Delay) for Vehicles is based on average delay for all vehicle movements. LOS Method: Delay (RTA NSW).

LOS Method for individual vehicle movements and lanes: Delay (RTA NSW).

Roundabout Capacity Model: SIDRA Standard.

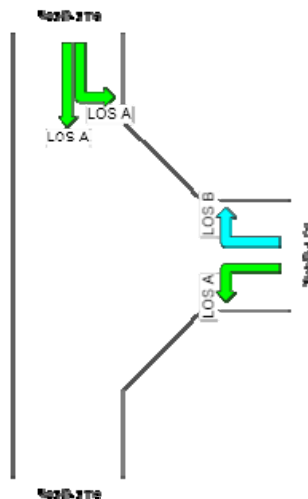

# INTERSECTION SUMMARY

Site: 4358-Princes/South Entrance

Intersection Performance - Hourly Values		
Performance Measure	Vehicles	Persons
Demand Flows (Total)	1713 veh/h	2055 pers/h
Percent Heavy Vehicles	7.0%	
Degree of Saturation	0.448	
Practical Spare Capacity	89.6%	
Effective Intersection Capacity	3819 veh/h	
Control Delay (Total)	2.64 veh-h/h	3.17 pers-h/h
Control Delay (Average)	5.6 sec	5.6 sec
Control Delay (Worst Lane)	15.2 sec	
Control Delay (Worst Movement)	15.2 sec	15.2 sec
Geometric Delay (Average)	5.1 sec	
Stop-Line Delay (Average)	0.4 sec	
Level of Service (Aver. Int. Delay)	LOS A	
Level of Service (Worst Movement)	LOS B	
Level of Service (Worst Lane)	LOS B	
95% Back of Queue - Vehicles (Worst Lane)	0.9 veh	
95% Back of Queue - Distance (Worst Lane)	6.3 m	
Total Effective Stops	797 veh/h	956 pers/h
Effective Stop Rate	0.47 per veh	0.47 per pers
Proportion Queued	0.08	0.08
Performance Index	25.0	25.0
Travel Distance (Total)	1049.1 veh-km/h	1258.9 pers-km/h
Travel Distance (Average)	613 m	613 m
Travel Time (Total)	20.1 veh-h/h	24.1 pers-h/h
Travel Time (Average)	42.2 sec	42.2 sec
Travel Speed	52.2 km/h	52.2 km/h
Cost (Total)	685.57 \$/h	685.57 \$/h
Fuel Consumption (Total)	120.5 L/h	
Carbon Dioxide (Total)	302.1 kg/h	
Hydrocarbons (Total)	0.437 kg/h	
Carbon Monoxide (Total)	20.65 kg/h	
NOx (Total)	0.693 kg/h	

LOS (Aver. Int. Delay) for Vehicles is based on average delay for all vehicle movements. LOS Method: Delay (RTA NSW).

LOS Method for individual vehicle movements and lanes: Delay (RTA NSW).

Roundabout Capacity Model: SIDRA Standard.

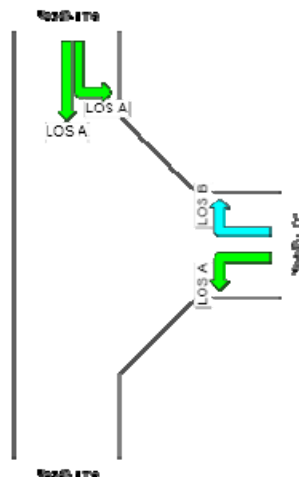

# INTERSECTION SUMMARY

Site: 2833-F6 Off Ramp/Haywards

Intersection Performance - Hourly Values		
Performance Measure	Vehicles	Persons
Demand Flows (Total)	716veh/h	859pers/h
Percent Heavy Vehicles	7.0%	
Degree of Saturation	0.174	
Practical Spare Capacity	387.8%	
Effective Intersection Capacity	4108veh/h	
Control Delay (Total)	1.82veh-h/h	2.18pers-h/h
Control Delay (Average)	9.1sec	9.1sec
Control Delay (Worst Lane)	12.0sec	
Control Delay (Worst Movement)	12.0sec	12.0sec
Geometric Delay (Average)	8.4sec	
Stop-Line Delay (Average)	0.7sec	
Level of Service (Aver. Int. Delay)	LOS A	
Level of Service (Worst Movement)	LOS A	
Level of Service (Worst Lane)	LOS A	
95% Back of Queue - Vehicles (Worst Lane)	0.9veh	
95% Back of Queue - Distance (Worst Lane)	6.5m	
Total Effective Stops	431veh/h	517pers/h
Effective Stop Rate	0.60per veh	0.60per pers
Proportion Queued	0.24	0.24
Performance Index	12.5	12.5
Travel Distance (Total)	455.6veh-km/h	546.7pers-km/h
Travel Distance (Average)	637m	637m
Travel Time (Total)	9.5veh-h/h	11.4pers-h/h
Travel Time (Average)	47.9sec	47.9sec
Travel Speed	47.9km/h	47.9km/h
Cost (Total)	323.91\$/h	323.91\$/h
Fuel Consumption (Total)	56.7L/h	
Carbon Dioxide (Total)	142.1kg/h	
Hydrocarbons (Total)	0.215kg/h	
Carbon Monoxide (Total)	10.68kg/h	
NOx (Total)	0.337kg/h	

LOS (Aver. Int. Delay) for Vehicles is based on average delay for all vehicle movements. LOS Method: Delay (RTA NSW).

LOS Method for individual vehicle movements and lanes: Delay (RTA NSW).

Roundabout Capacity Model: SIDRA Standard.

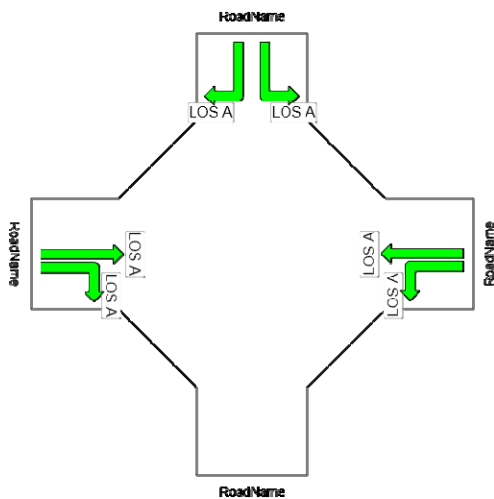

# INTERSECTION SUMMARY

Site: 2813-Haywards/Yallah Rd

Intersection Performance - Hourly Values		
Performance Measure	Vehicles	Persons
Demand Flows (Total)	808veh/h	970pers/h
Percent Heavy Vehicles	7.0%	
Degree of Saturation	0.205	
Practical Spare Capacity	315.0%	
Effective Intersection Capacity	3947veh/h	
Control Delay (Total)	1.96veh-h/h	2.36pers-h/h
Control Delay (Average)	8.7sec	8.7sec
Control Delay (Worst Lane)	11.3sec	
Control Delay (Worst Movement)	12.8sec	12.8sec
Geometric Delay (Average)	8.3sec	
Stop-Line Delay (Average)	0.5sec	
Level of Service (Aver. Int. Delay)	LOS A	
Level of Service (Worst Movement)	LOS A	
Level of Service (Worst Lane)	LOS A	
95% Back of Queue - Vehicles (Worst Lane)	1.2veh	
95% Back of Queue - Distance (Worst Lane)	8.8m	
Total Effective Stops	481veh/h	577pers/h
Effective Stop Rate	0.60per veh	0.60per pers
Proportion Queued	0.18	0.18
Performance Index	14.2	14.2
Travel Distance (Total)	513.2veh-km/h	615.9pers-km/h
Travel Distance (Average)	635m	635m
Travel Time (Total)	10.6veh-h/h	12.7pers-h/h
Travel Time (Average)	47.3sec	47.3sec
Travel Speed	48.4km/h	48.4km/h
Cost (Total)	361.55\$/h	361.55\$/h
Fuel Consumption (Total)	63.4L/h	
Carbon Dioxide (Total)	159.0kg/h	
Hydrocarbons (Total)	0.240kg/h	
Carbon Monoxide (Total)	11.90kg/h	
NOx (Total)	0.376kg/h	

LOS (Aver. Int. Delay) for Vehicles is based on average delay for all vehicle movements. LOS Method: Delay (RTA NSW).

LOS Method for individual vehicle movements and lanes: Delay (RTA NSW).

Roundabout Capacity Model: SIDRA Standard.

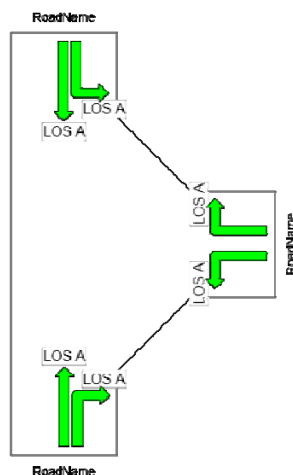

# INTERSECTION SUMMARY

Site: 2138-Main Entrance/Main N/S

Intersection Performance - Hourly Values		
Performance Measure	Vehicles	Persons
Demand Flows (Total)	1233 veh/h	1479 pers/h
Percent Heavy Vehicles	7.0%	
Degree of Saturation	0.516	
Practical Spare Capacity	64.6%	
Effective Intersection Capacity	2387 veh/h	
Control Delay (Total)	2.30 veh-h/h	2.76 pers-h/h
Control Delay (Average)	6.7 sec	6.7 sec
Control Delay (Worst Lane)	9.6 sec	
Control Delay (Worst Movement)	13.6 sec	13.6 sec
Geometric Delay (Average)	5.1 sec	
Stop-Line Delay (Average)	1.6 sec	
Level of Service (Aver. Int. Delay)	LOS A	
Level of Service (Worst Movement)	LOS A	
Level of Service (Worst Lane)	LOS A	
95% Back of Queue - Vehicles (Worst Lane)	5.2 veh	
95% Back of Queue - Distance (Worst Lane)	38.4 m	
Total Effective Stops	713 veh/h	855 pers/h
Effective Stop Rate	0.58 per veh	0.58 per pers
Proportion Queued	0.49	0.49
Performance Index	23.8	23.8
Travel Distance (Total)	719.6 veh-km/h	863.5 pers-km/h
Travel Distance (Average)	584 m	584 m
Travel Time (Total)	17.0 veh-h/h	20.4 pers-h/h
Travel Time (Average)	49.6 sec	49.6 sec
Travel Speed	42.3 km/h	42.3 km/h
Cost (Total)	496.08 \$/h	496.08 \$/h
Fuel Consumption (Total)	83.1 L/h	
Carbon Dioxide (Total)	208.3 kg/h	
Hydrocarbons (Total)	0.313 kg/h	
Carbon Monoxide (Total)	14.24 kg/h	
NOx (Total)	0.441 kg/h	

LOS (Aver. Int. Delay) for Vehicles is based on average delay for all vehicle movements. LOS Method: Delay (RTA NSW).

LOS Method for individual vehicle movements and lanes: Delay (RTA NSW).

Roundabout Capacity Model: SIDRA Standard.

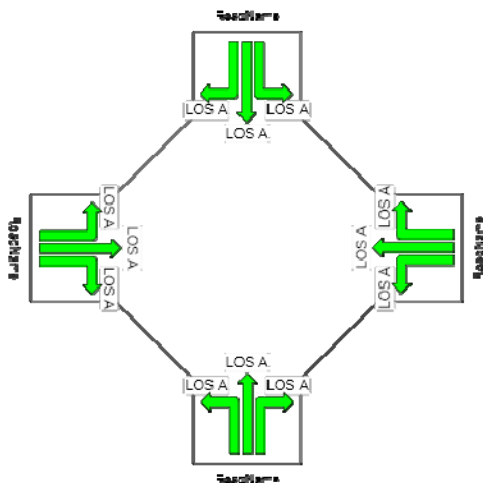

# INTERSECTION SUMMARY

Site: 2135- Main Entrance/Duck Creek

Intersection Performance - Hourly Values		
Performance Measure	Vehicles	Persons
Demand Flows (Total)	792 veh/h	950 pers/h
Percent Heavy Vehicles	7.0%	
Degree of Saturation	0.334	
Practical Spare Capacity	154.2%	
Effective Intersection Capacity	2367 veh/h	
Control Delay (Total)	1.59 veh-h/h	1.90 pers-h/h
Control Delay (Average)	7.2 sec	7.2 sec
Control Delay (Worst Lane)	9.8 sec	
Control Delay (Worst Movement)	11.3 sec	11.3 sec
Geometric Delay (Average)	6.5 sec	
Stop-Line Delay (Average)	0.7 sec	
Level of Service (Aver. Int. Delay)	LOS A	
Level of Service (Worst Movement)	LOS A	
Level of Service (Worst Lane)	LOS A	
95% Back of Queue - Vehicles (Worst Lane)	2.7 veh	
95% Back of Queue - Distance (Worst Lane)	20.3 m	
Total Effective Stops	448 veh/h	538 pers/h
Effective Stop Rate	0.57 per veh	0.57 per pers
Proportion Queued	0.28	0.28
Performance Index	14.9	14.9
Travel Distance (Total)	467.6 veh-km/h	561.2 pers-km/h
Travel Distance (Average)	591 m	591 m
Travel Time (Total)	11.1 veh-h/h	13.3 pers-h/h
Travel Time (Average)	50.3 sec	50.3 sec
Travel Speed	42.3 km/h	42.3 km/h
Cost (Total)	321.78 \$/h	321.78 \$/h
Fuel Consumption (Total)	53.7 L/h	
Carbon Dioxide (Total)	134.7 kg/h	
Hydrocarbons (Total)	0.203 kg/h	
Carbon Monoxide (Total)	9.18 kg/h	
NOx (Total)	0.283 kg/h	

LOS (Aver. Int. Delay) for Vehicles is based on average delay for all vehicle movements. LOS Method: Delay (RTA NSW).

LOS Method for individual vehicle movements and lanes: Delay (RTA NSW).

Roundabout Capacity Model: SIDRA Standard.

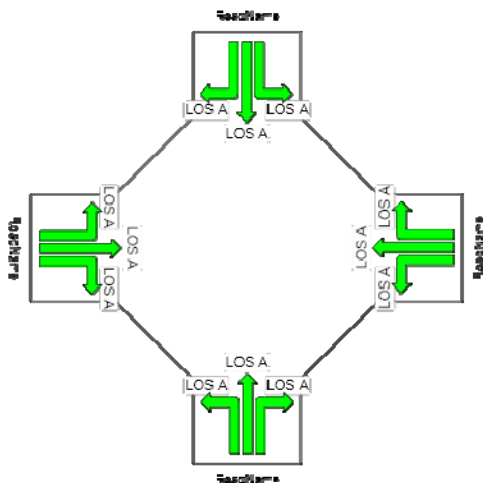

# INTERSECTION SUMMARY

Site: 2181-South Entrance/Main N/S

Intersection Performance - Hourly Values		
Performance Measure	Vehicles	Persons
Demand Flows (Total)	612veh/h	734pers/h
Percent Heavy Vehicles	7.0%	
Degree of Saturation	0.214	
Practical Spare Capacity	297.8%	
Effective Intersection Capacity	2862veh/h	
Control Delay (Total)	0.84veh-h/h	1.01pers-h/h
Control Delay (Average)	5.0sec	5.0sec
Control Delay (Worst Lane)	8.2sec	
Control Delay (Worst Movement)	10.4sec	10.4sec
Geometric Delay (Average)	4.5sec	
Stop-Line Delay (Average)	0.4sec	
Level of Service (Aver. Int. Delay)	LOS A	
Level of Service (Worst Movement)	LOS A	
Level of Service (Worst Lane)	LOS A	
95% Back of Queue - Vehicles (Worst Lane)	1.5veh	
95% Back of Queue - Distance (Worst Lane)	11.2m	
Total Effective Stops	274veh/h	328pers/h
Effective Stop Rate	0.45per veh	0.45per pers
Proportion Queued	0.18	0.18
Performance Index	10.4	10.4
Travel Distance (Total)	355.0veh-km/h	425.9pers-km/h
Travel Distance (Average)	580m	580m
Travel Time (Total)	8.0veh-h/h	9.6pers-h/h
Travel Time (Average)	47.1sec	47.1sec
Travel Speed	44.3km/h	44.3km/h
Cost (Total)	232.51\$/h	232.51\$/h
Fuel Consumption (Total)	38.7L/h	
Carbon Dioxide (Total)	97.0kg/h	
Hydrocarbons (Total)	0.142kg/h	
Carbon Monoxide (Total)	6.20kg/h	
NOx (Total)	0.198kg/h	

LOS (Aver. Int. Delay) for Vehicles is based on average delay for all vehicle movements. LOS Method: Delay (RTA NSW).

LOS Method for individual vehicle movements and lanes: Delay (RTA NSW).

Roundabout Capacity Model: SIDRA Standard.

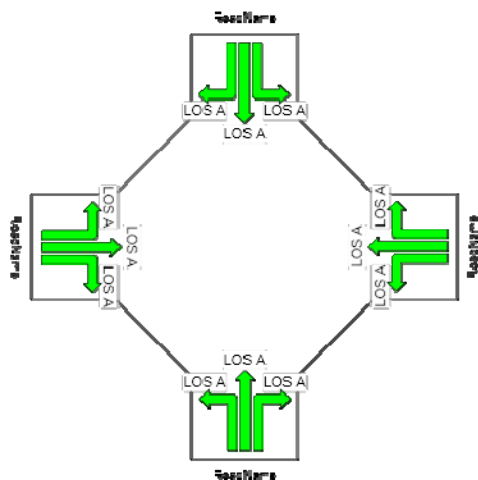

#### 4. 2036 Highway/Internal Intersections with Tallawarra–No Haywards Link-PMP **INTERSECTION SUMMARY** Site: 2557- F6 Off Ramp/Princes

Intersection Performance - Hourly Values		
Performance Measure	Vehicles	Persons
Demand Flows (Total)	3247veh/h	3897pers/h
Percent Heavy Vehicles	7.0%	
Degree of Saturation	0.835	
Practical Spare Capacity	1.9%	
Effective Intersection Capacity	3891veh/h	
Control Delay (Total)	9.60veh-h/h	11.52pers-h/h
Control Delay (Average)	10.6sec	10.6sec
Control Delay (Worst Lane)	14.1sec	
Control Delay (Worst Movement)	14.1sec	14.1sec
Geometric Delay (Average)	6.1sec	
Stop-Line Delay (Average)	4.6sec	
Level of Service (Aver. Int. Delay)	LOS A	
Level of Service (Worst Movement)	LOS A	
Level of Service (Worst Lane)	LOS A	
95% Back of Queue - Vehicles (Worst Lane)	12.4veh	
95% Back of Queue - Distance (Worst Lane)	92.2m	
Total Effective Stops	2774veh/h	3329pers/h
Effective Stop Rate	0.85per veh	0.85per pers
Proportion Queued	0.69	0.69
Performance Index	70.0	70.0
Travel Distance (Total)	2007.8veh-km/h	2409.3pers-km/h
Travel Distance (Average)	618m	618m
Travel Time (Total)	43.0veh-h/h	51.5pers-h/h
Travel Time (Average)	47.6sec	47.6sec
Travel Speed	46.7km/h	46.7km/h
Cost (Total)	1478.77\$/h	1478.77\$/h
Fuel Consumption (Total)	263.1L/h	
Carbon Dioxide (Total)	659.5kg/h	
Hydrocarbons (Total)	1.013kg/h	
Carbon Monoxide (Total)	51.98kg/h	
NOx (Total)	1.615kg/h	

LOS (Aver. Int. Delay) for Vehicles is based on average delay for all vehicle movements. LOS Method: Delay (RTA NSW).

LOS Method for individual vehicle movements and lanes: Delay (RTA NSW).

Roundabout Capacity Model: SIDRA Standard.

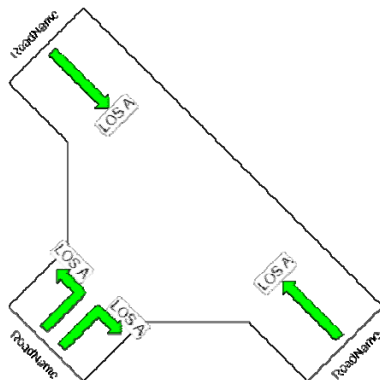

# INTERSECTION SUMMARY

Site: 2469-Princes/Cormack

Intersection Performance - Hourly Values		
Performance Measure	Vehicles	Persons
Demand Flows (Total)	2621 veh/h	3145 pers/h
Percent Heavy Vehicles	7.0%	
Degree of Saturation	0.570	
Practical Spare Capacity	49.2%	
Effective Intersection Capacity	4600 veh/h	
Control Delay (Total)	4.49 veh-h/h	5.39 pers-h/h
Control Delay (Average)	6.2 sec	6.2 sec
Control Delay (Worst Lane)	16.6 sec	
Control Delay (Worst Movement)	16.6 sec	16.6 sec
Geometric Delay (Average)	5.0 sec	
Stop-Line Delay (Average)	1.1 sec	
Level of Service (Aver. Int. Delay)	LOS A	
Level of Service (Worst Movement)	LOS B	
Level of Service (Worst Lane)	LOS B	
95% Back of Queue - Vehicles (Worst Lane)	5.3 veh	
95% Back of Queue - Distance (Worst Lane)	39.7 m	
Total Effective Stops	1304 veh/h	1565 pers/h
Effective Stop Rate	0.50 per veh	0.50 per pers
Proportion Queued	0.25	0.25
Performance Index	43.8	43.8
Travel Distance (Total)	1603.4 veh-km/h	1924.1 pers-km/h
Travel Distance (Average)	612 m	612 m
Travel Time (Total)	31.6 veh-h/h	37.9 pers-h/h
Travel Time (Average)	43.4 sec	43.4 sec
Travel Speed	50.8 km/h	50.8 km/h
Cost (Total)	1080.24 \$/h	1080.24 \$/h
Fuel Consumption (Total)	190.6 L/h	
Carbon Dioxide (Total)	477.7 kg/h	
Hydrocarbons (Total)	0.702 kg/h	
Carbon Monoxide (Total)	33.97 kg/h	
NOx (Total)	1.117 kg/h	

LOS (Aver. Int. Delay) for Vehicles is based on average delay for all vehicle movements. LOS Method: Delay (RTA NSW).

LOS Method for individual vehicle movements and lanes: Delay (RTA NSW).

Roundabout Capacity Model: SIDRA Standard.

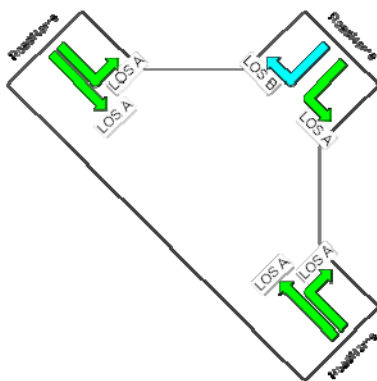

# INTERSECTION SUMMARY

Site: 2467-Princes/Main Entrance

Intersection Performance - Hourly Values		
Performance Measure	Vehicles	Persons
Demand Flows (Total)	2402 veh/h	2883 pers/h
Percent Heavy Vehicles	7.0%	
Degree of Saturation	0.571	
Practical Spare Capacity	48.9%	
Effective Intersection Capacity	4207 veh/h	
Control Delay (Total)	4.41 veh-h/h	5.29 pers-h/h
Control Delay (Average)	6.6 sec	6.6 sec
Control Delay (Worst Lane)	17.7 sec	
Control Delay (Worst Movement)	17.6 sec	17.6 sec
Geometric Delay (Average)	5.4 sec	
Stop-Line Delay (Average)	1.2 sec	
Level of Service (Aver. Int. Delay)	LOS A	
Level of Service (Worst Movement)	LOS B	
Level of Service (Worst Lane)	LOS B	
95% Back of Queue - Vehicles (Worst Lane)	2.0 veh	
95% Back of Queue - Distance (Worst Lane)	15.1 m	
Total Effective Stops	1239 veh/h	1487 pers/h
Effective Stop Rate	0.52 per veh	0.52 per pers
Proportion Queued	0.15	0.15
Performance Index	37.2	37.2
Travel Distance (Total)	1477.8 veh-km/h	1773.3 pers-km/h
Travel Distance (Average)	615 m	615 m
Travel Time (Total)	28.9 veh-h/h	34.7 pers-h/h
Travel Time (Average)	43.4 sec	43.4 sec
Travel Speed	51.0 km/h	51.0 km/h
Cost (Total)	985.74 \$/h	985.74 \$/h
Fuel Consumption (Total)	172.4 L/h	
Carbon Dioxide (Total)	432.2 kg/h	
Hydrocarbons (Total)	0.630 kg/h	
Carbon Monoxide (Total)	30.00 kg/h	
NOx (Total)	0.996 kg/h	

LOS (Aver. Int. Delay) for Vehicles is based on average delay for all vehicle movements. LOS Method: Delay (RTA NSW).

LOS Method for individual vehicle movements and lanes: Delay (RTA NSW).

Roundabout Capacity Model: SIDRA Standard.

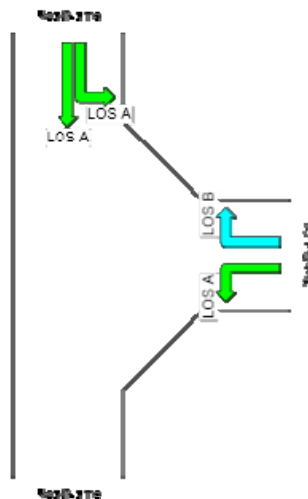

# INTERSECTION SUMMARY

Site: 4358-Princes/South Entrance

Intersection Performance - Hourly Values		
Performance Measure	Vehicles	Persons
Demand Flows (Total)	2237veh/h	2684pers/h
Percent Heavy Vehicles	7.0%	
Degree of Saturation	0.568	
Practical Spare Capacity	49.7%	
Effective Intersection Capacity	3940veh/h	
Control Delay (Total)	3.60veh-h/h	4.32pers-h/h
Control Delay (Average)	5.8sec	5.8sec
Control Delay (Worst Lane)	17.2sec	
Control Delay (Worst Movement)	17.2sec	17.2sec
Geometric Delay (Average)	5.0sec	
Stop-Line Delay (Average)	0.8sec	
Level of Service (Aver. Int. Delay)	LOS A	
Level of Service (Worst Movement)	LOS B	
Level of Service (Worst Lane)	LOS B	
95% Back of Queue - Vehicles (Worst Lane)	1.8veh	
95% Back of Queue - Distance (Worst Lane)	13.3m	
Total Effective Stops	1066veh/h	1279pers/h
Effective Stop Rate	0.48per veh	0.48per pers
Proportion Queued	0.12	0.12
Performance Index	33.2	33.2
Travel Distance (Total)	1371.4veh-km/h	1645.7pers-km/h
Travel Distance (Average)	613m	613m
Travel Time (Total)	26.4veh-h/h	31.7pers-h/h
Travel Time (Average)	42.5sec	42.5sec
Travel Speed	52.0km/h	52.0km/h
Cost (Total)	898.14\$/h	898.14\$/h
Fuel Consumption (Total)	157.1L/h	
Carbon Dioxide (Total)	393.9kg/h	
Hydrocarbons (Total)	0.569kg/h	
Carbon Monoxide (Total)	26.75kg/h	
NOx (Total)	0.901kg/h	

LOS (Aver. Int. Delay) for Vehicles is based on average delay for all vehicle movements. LOS Method: Delay (RTA NSW).

LOS Method for individual vehicle movements and lanes: Delay (RTA NSW).

Roundabout Capacity Model: SIDRA Standard.

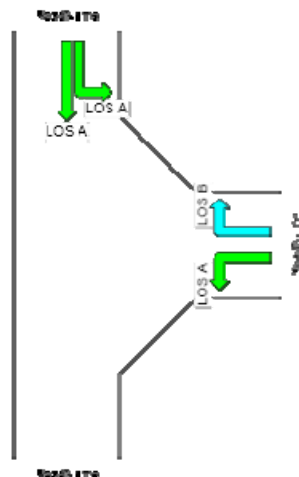

# INTERSECTION SUMMARY

Site: 2833-F6 Off Ramp/Haywards

Intersection Performance - Hourly Values		
Performance Measure	Vehicles	Persons
Demand Flows (Total)	973 veh/h	1167 pers/h
Percent Heavy Vehicles	7.0%	
Degree of Saturation	0.267	
Practical Spare Capacity	218.4%	
Effective Intersection Capacity	3643 veh/h	
Control Delay (Total)	2.67 veh-h/h	3.21 pers-h/h
Control Delay (Average)	9.9 sec	9.9 sec
Control Delay (Worst Lane)	12.5 sec	
Control Delay (Worst Movement)	12.5 sec	12.5 sec
Geometric Delay (Average)	8.9 sec	
Stop-Line Delay (Average)	1.0 sec	
Level of Service (Aver. Int. Delay)	LOS A	
Level of Service (Worst Movement)	LOS A	
Level of Service (Worst Lane)	LOS A	
95% Back of Queue - Vehicles (Worst Lane)	1.5 veh	
95% Back of Queue - Distance (Worst Lane)	10.8 m	
Total Effective Stops	630 veh/h	756 pers/h
Effective Stop Rate	0.65 per veh	0.65 per pers
Proportion Queued	0.28	0.28
Performance Index	17.6	17.6
Travel Distance (Total)	621.8 veh-km/h	746.1 pers-km/h
Travel Distance (Average)	639 m	639 m
Travel Time (Total)	13.2 veh-h/h	15.8 pers-h/h
Travel Time (Average)	48.7 sec	48.7 sec
Travel Speed	47.3 km/h	47.3 km/h
Cost (Total)	447.29 \$/h	447.29 \$/h
Fuel Consumption (Total)	78.2 L/h	
Carbon Dioxide (Total)	196.0 kg/h	
Hydrocarbons (Total)	0.298 kg/h	
Carbon Monoxide (Total)	14.90 kg/h	
NOx (Total)	0.467 kg/h	

LOS (Aver. Int. Delay) for Vehicles is based on average delay for all vehicle movements. LOS Method: Delay (RTA NSW).

LOS Method for individual vehicle movements and lanes: Delay (RTA NSW).

Roundabout Capacity Model: SIDRA Standard.

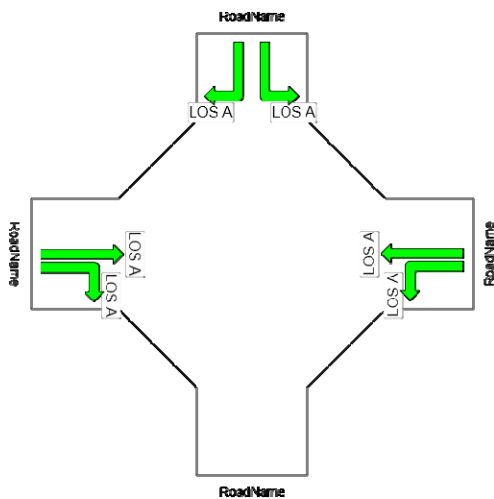

# INTERSECTION SUMMARY

Site: 2813-Haywards/Yallah Rd

Intersection Performance - Hourly Values		
Performance Measure	Vehicles	Persons
Demand Flows (Total)	949veh/h	1139pers/h
Percent Heavy Vehicles	7.0%	
Degree of Saturation	0.241	
Practical Spare Capacity	252.7%	
Effective Intersection Capacity	3940veh/h	
Control Delay (Total)	2.34veh-h/h	2.81pers-h/h
Control Delay (Average)	8.9sec	8.9sec
Control Delay (Worst Lane)	11.3sec	
Control Delay (Worst Movement)	13.1sec	13.1sec
Geometric Delay (Average)	8.4sec	
Stop-Line Delay (Average)	0.5sec	
Level of Service (Aver. Int. Delay)	LOS A	
Level of Service (Worst Movement)	LOS A	
Level of Service (Worst Lane)	LOS A	
95% Back of Queue - Vehicles (Worst Lane)	1.5veh	
95% Back of Queue - Distance (Worst Lane)	10.8m	
Total Effective Stops	567veh/h	680pers/h
Effective Stop Rate	0.60per veh	0.60per pers
Proportion Queued	0.17	0.17
Performance Index	16.8	16.8
Travel Distance (Total)	602.6veh-km/h	723.2pers-km/h
Travel Distance (Average)	635m	635m
Travel Time (Total)	12.5veh-h/h	15.0pers-h/h
Travel Time (Average)	47.4sec	47.4sec
Travel Speed	48.2km/h	48.2km/h
Cost (Total)	425.80\$/h	425.80\$/h
Fuel Consumption (Total)	74.8L/h	
Carbon Dioxide (Total)	187.5kg/h	
Hydrocarbons (Total)	0.283kg/h	
Carbon Monoxide (Total)	14.10kg/h	
NOx (Total)	0.445kg/h	

LOS (Aver. Int. Delay) for Vehicles is based on average delay for all vehicle movements. LOS Method: Delay (RTA NSW).

LOS Method for individual vehicle movements and lanes: Delay (RTA NSW).

Roundabout Capacity Model: SIDRA Standard.

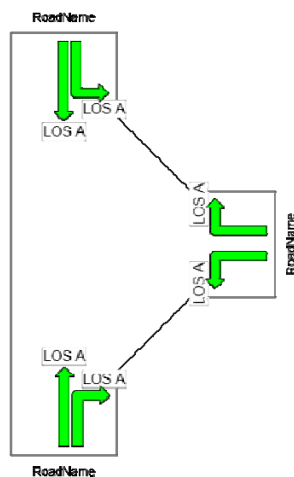

# INTERSECTION SUMMARY

Site: 2138-Main Entrance/Main N/S

Intersection Performance - Hourly Values		
Performance Measure	Vehicles	Persons
Demand Flows (Total)	1041 veh/h	1249 pers/h
Percent Heavy Vehicles	7.0%	
Degree of Saturation	0.403	
Practical Spare Capacity	110.6%	
Effective Intersection Capacity	2579 veh/h	
Control Delay (Total)	1.98 veh-h/h	2.38 pers-h/h
Control Delay (Average)	6.9 sec	6.9 sec
Control Delay (Worst Lane)	8.3 sec	
Control Delay (Worst Movement)	11.6 sec	11.6 sec
Geometric Delay (Average)	5.2 sec	
Stop-Line Delay (Average)	1.7 sec	
Level of Service (Aver. Int. Delay)	LOS A	
Level of Service (Worst Movement)	LOS A	
Level of Service (Worst Lane)	LOS A	
95% Back of Queue - Vehicles (Worst Lane)	3.3 veh	
95% Back of Queue - Distance (Worst Lane)	24.1 m	
Total Effective Stops	626 veh/h	751 pers/h
Effective Stop Rate	0.60 per veh	0.60 per pers
Proportion Queued	0.48	0.48
Performance Index	20.0	20.0
Travel Distance (Total)	608.3 veh-km/h	730.0 pers-km/h
Travel Distance (Average)	584 m	584 m
Travel Time (Total)	14.4 veh-h/h	17.3 pers-h/h
Travel Time (Average)	49.7 sec	49.7 sec
Travel Speed	42.3 km/h	42.3 km/h
Cost (Total)	419.82 \$/h	419.82 \$/h
Fuel Consumption (Total)	70.4 L/h	
Carbon Dioxide (Total)	176.4 kg/h	
Hydrocarbons (Total)	0.265 kg/h	
Carbon Monoxide (Total)	12.09 kg/h	
NOx (Total)	0.374 kg/h	

LOS (Aver. Int. Delay) for Vehicles is based on average delay for all vehicle movements. LOS Method: Delay (RTA NSW).

LOS Method for individual vehicle movements and lanes: Delay (RTA NSW).

Roundabout Capacity Model: SIDRA Standard.

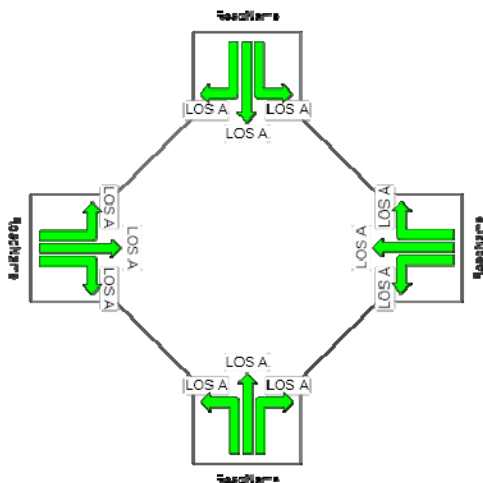

# INTERSECTION SUMMARY

Site: 2135- Main Entrance/Duck Creek

Intersection Performance - Hourly Values		
Performance Measure	Vehicles	Persons
Demand Flows (Total)	629 veh/h	755 pers/h
Percent Heavy Vehicles	7.0%	
Degree of Saturation	0.229	
Practical Spare Capacity	271.5%	
Effective Intersection Capacity	2751 veh/h	
Control Delay (Total)	1.06 veh-h/h	1.27 pers-h/h
Control Delay (Average)	6.1 sec	6.1 sec
Control Delay (Worst Lane)	8.9 sec	
Control Delay (Worst Movement)	9.9 sec	9.9 sec
Geometric Delay (Average)	5.4 sec	
Stop-Line Delay (Average)	0.6 sec	
Level of Service (Aver. Int. Delay)	LOS A	
Level of Service (Worst Movement)	LOS A	
Level of Service (Worst Lane)	LOS A	
95% Back of Queue - Vehicles (Worst Lane)	1.6 veh	
95% Back of Queue - Distance (Worst Lane)	11.9m	
Total Effective Stops	324 veh/h	388 pers/h
Effective Stop Rate	0.51 per veh	0.51 per pers
Proportion Queued	0.28	0.28
Performance Index	11.3	11.3
Travel Distance (Total)	367.3 veh-km/h	440.7 pers-km/h
Travel Distance (Average)	583m	583m
Travel Time (Total)	8.5 veh-h/h	10.2 pers-h/h
Travel Time (Average)	48.7 sec	48.7 sec
Travel Speed	43.1 km/h	43.1 km/h
Cost (Total)	248.33\$/h	248.33\$/h
Fuel Consumption (Total)	41.6L/h	
Carbon Dioxide (Total)	104.2kg/h	
Hydrocarbons (Total)	0.155kg/h	
Carbon Monoxide (Total)	6.99kg/h	
NOx (Total)	0.218kg/h	

LOS (Aver. Int. Delay) for Vehicles is based on average delay for all vehicle movements. LOS Method: Delay (RTA NSW).

LOS Method for individual vehicle movements and lanes: Delay (RTA NSW).

Roundabout Capacity Model: SIDRA Standard.

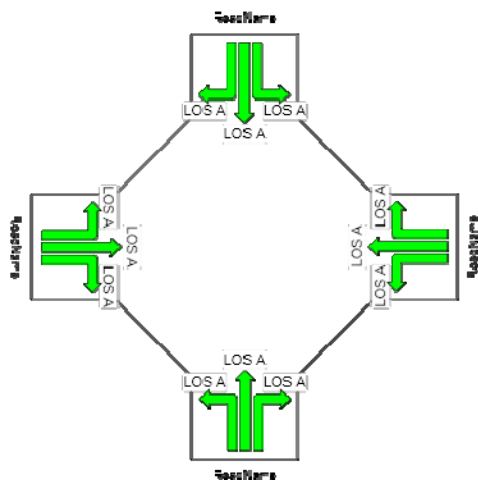

# INTERSECTION SUMMARY

Site: 2181-South Entrance/Main N/S

Intersection Performance - Hourly Values		
Performance Measure	Vehicles	Persons
Demand Flows (Total)	558veh/h	669pers/h
Percent Heavy Vehicles	7.0%	
Degree of Saturation	0.164	
Practical Spare Capacity	417.3%	
Effective Intersection Capacity	3396veh/h	
Control Delay (Total)	0.78veh-h/h	0.94pers-h/h
Control Delay (Average)	5.0sec	5.0sec
Control Delay (Worst Lane)	7.3sec	
Control Delay (Worst Movement)	9.8sec	9.8sec
Geometric Delay (Average)	4.7sec	
Stop-Line Delay (Average)	0.3sec	
Level of Service (Aver. Int. Delay)	LOS A	
Level of Service (Worst Movement)	LOS A	
Level of Service (Worst Lane)	LOS A	
95% Back of Queue - Vehicles (Worst Lane)	1.1veh	
95% Back of Queue - Distance (Worst Lane)	8.3m	
Total Effective Stops	256veh/h	307pers/h
Effective Stop Rate	0.46per veh	0.46per pers
Proportion Queued	0.17	0.17
Performance Index	9.5	9.5
Travel Distance (Total)	323.6veh-km/h	388.3pers-km/h
Travel Distance (Average)	580m	580m
Travel Time (Total)	7.3veh-h/h	8.8pers-h/h
Travel Time (Average)	47.2sec	47.2sec
Travel Speed	44.2km/h	44.2km/h
Cost (Total)	212.97\$/h	212.97\$/h
Fuel Consumption (Total)	35.5L/h	
Carbon Dioxide (Total)	89.1kg/h	
Hydrocarbons (Total)	0.131kg/h	
Carbon Monoxide (Total)	5.76kg/h	
NOx (Total)	0.183kg/h	

LOS (Aver. Int. Delay) for Vehicles is based on average delay for all vehicle movements. LOS Method: Delay (RTA NSW).

LOS Method for individual vehicle movements and lanes: Delay (RTA NSW).

Roundabout Capacity Model: SIDRA Standard.

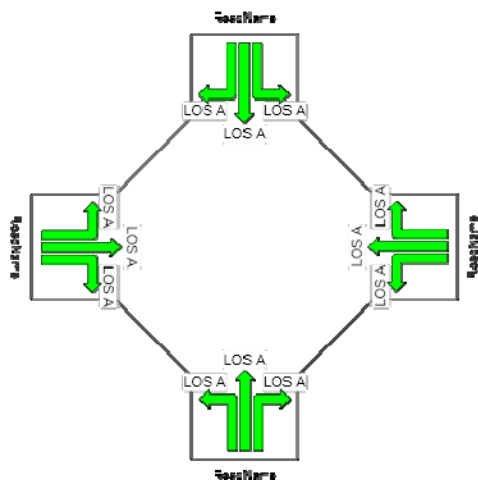

5. 2036 Highway/Internal Intersections with Tallawarra–With Haywards Link-AMP  
**INTERSECTION SUMMARY** Site: 2557- F6 Off Ramp/Princes

Intersection Performance - Hourly Values		
Performance Measure	Vehicles	Persons
Demand Flows (Total)	2962veh/h	3555pers/h
Percent Heavy Vehicles	7.0%	
Degree of Saturation	0.953	
Practical Spare Capacity	-10.8%	
Effective Intersection Capacity	3107veh/h	
Control Delay (Total)	9.13veh-h/h	10.95pers-h/h
Control Delay (Average)	11.1sec	11.1sec
Control Delay (Worst Lane)	14.9sec	
Control Delay (Worst Movement)	14.9sec	14.9sec
Geometric Delay (Average)	6.0sec	
Stop-Line Delay (Average)	5.1sec	
Level of Service (Aver. Int. Delay)	LOS A	
Level of Service (Worst Movement)	LOS B	
Level of Service (Worst Lane)	LOS B	
95% Back of Queue - Vehicles (Worst Lane)	28.3veh	
95% Back of Queue - Distance (Worst Lane)	209.9m	
Total Effective Stops	2274veh/h	2729pers/h
Effective Stop Rate	0.77per veh	0.77per pers
Proportion Queued	0.73	0.73
Performance Index	66.1	66.1
Travel Distance (Total)	1825.3veh-km/h	2190.3pers-km/h
Travel Distance (Average)	616m	616m
Travel Time (Total)	40.0veh-h/h	48.0pers-h/h
Travel Time (Average)	48.7sec	48.7sec
Travel Speed	45.6km/h	45.6km/h
Cost (Total)	1381.76\$/h	1381.76\$/h
Fuel Consumption (Total)	245.0L/h	
Carbon Dioxide (Total)	614.1kg/h	
Hydrocarbons (Total)	0.952kg/h	
Carbon Monoxide (Total)	49.30kg/h	
NOx (Total)	1.515kg/h	

LOS (Aver. Int. Delay) for Vehicles is based on average delay for all vehicle movements. LOS Method: Delay (RTA NSW).

LOS Method for individual vehicle movements and lanes: Delay (RTA NSW).

Roundabout Capacity Model: SIDRA Standard.

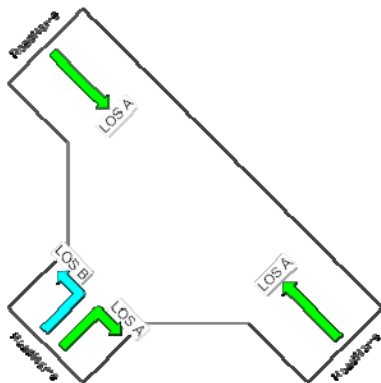

# INTERSECTION SUMMARY

Site: 2469-Princes/Cormack

Intersection Performance - Hourly Values		
Performance Measure	Vehicles	Persons
Demand Flows (Total)	1983 veh/h	2380 pers/h
Percent Heavy Vehicles	7.0%	
Degree of Saturation	0.441	
Practical Spare Capacity	92.5%	
Effective Intersection Capacity	4491 veh/h	
Control Delay (Total)	3.24 veh-h/h	3.89 pers-h/h
Control Delay (Average)	5.9 sec	5.9 sec
Control Delay (Worst Lane)	15.7 sec	
Control Delay (Worst Movement)	15.7 sec	15.7 sec
Geometric Delay (Average)	5.1 sec	
Stop-Line Delay (Average)	0.8 sec	
Level of Service (Aver. Int. Delay)	LOS A	
Level of Service (Worst Movement)	LOS B	
Level of Service (Worst Lane)	LOS B	
95% Back of Queue - Vehicles (Worst Lane)	3.4 veh	
95% Back of Queue - Distance (Worst Lane)	25.1 m	
Total Effective Stops	952 veh/h	1142 pers/h
Effective Stop Rate	0.48 per veh	0.48 per pers
Proportion Queued	0.21	0.21
Performance Index	32.0	32.0
Travel Distance (Total)	1214.3 veh-km/h	1457.1 pers-km/h
Travel Distance (Average)	612 m	612 m
Travel Time (Total)	23.7 veh-h/h	28.5 pers-h/h
Travel Time (Average)	43.1 sec	43.1 sec
Travel Speed	51.2 km/h	51.2 km/h
Cost (Total)	811.69 \$/h	811.69 \$/h
Fuel Consumption (Total)	143.3 L/h	
Carbon Dioxide (Total)	359.3 kg/h	
Hydrocarbons (Total)	0.526 kg/h	
Carbon Monoxide (Total)	25.39 kg/h	
NOx (Total)	0.837 kg/h	

LOS (Aver. Int. Delay) for Vehicles is based on average delay for all vehicle movements. LOS Method: Delay (RTA NSW).

LOS Method for individual vehicle movements and lanes: Delay (RTA NSW).

Roundabout Capacity Model: SIDRA Standard.

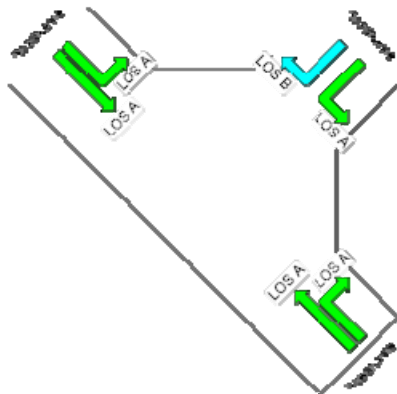

# INTERSECTION SUMMARY

Site: 2467-Princes/Main Entrance

Intersection Performance - Hourly Values		
Performance Measure	Vehicles	Persons
Demand Flows (Total)	1717veh/h	2060pers/h
Percent Heavy Vehicles	7.0%	
Degree of Saturation	0.447	
Practical Spare Capacity	90.0%	
Effective Intersection Capacity	3837veh/h	
Control Delay (Total)	2.73veh-h/h	3.27pers-h/h
Control Delay (Average)	5.7sec	5.7sec
Control Delay (Worst Lane)	15.0sec	
Control Delay (Worst Movement)	14.9sec	14.9sec
Geometric Delay (Average)	5.3sec	
Stop-Line Delay (Average)	0.5sec	
Level of Service (Aver. Int. Delay)	LOS A	
Level of Service (Worst Movement)	LOS B	
Level of Service (Worst Lane)	LOS B	
95% Back of Queue - Vehicles (Worst Lane)	0.7veh	
95% Back of Queue - Distance (Worst Lane)	5.3m	
Total Effective Stops	807veh/h	968pers/h
Effective Stop Rate	0.47per veh	0.47per pers
Proportion Queued	0.08	0.08
Performance Index	25.2	25.2
Travel Distance (Total)	1053.8veh-km/h	1264.5pers-km/h
Travel Distance (Average)	614m	614m
Travel Time (Total)	20.2veh-h/h	24.3pers-h/h
Travel Time (Average)	42.5sec	42.5sec
Travel Speed	52.0km/h	52.0km/h
Cost (Total)	690.43\$/h	690.43\$/h
Fuel Consumption (Total)	121.2L/h	
Carbon Dioxide (Total)	303.8kg/h	
Hydrocarbons (Total)	0.440kg/h	
Carbon Monoxide (Total)	20.80kg/h	
NOx (Total)	0.697kg/h	

LOS (Aver. Int. Delay) for Vehicles is based on average delay for all vehicle movements. LOS Method: Delay (RTA NSW).

LOS Method for individual vehicle movements and lanes: Delay (RTA NSW).

Roundabout Capacity Model: SIDRA Standard.

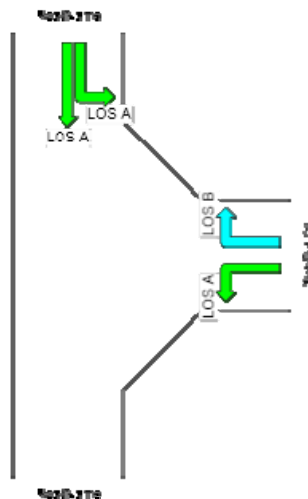

# INTERSECTION SUMMARY

Site: 4358-Princes/South Entrance

Intersection Performance - Hourly Values		
Performance Measure	Vehicles	Persons
Demand Flows (Total)	1336veh/h	1603pers/h
Percent Heavy Vehicles	7.0%	
Degree of Saturation	0.388	
Practical Spare Capacity	119.3%	
Effective Intersection Capacity	3446veh/h	
Control Delay (Total)	1.87veh-h/h	2.25pers-h/h
Control Delay (Average)	5.0sec	5.0sec
Control Delay (Worst Lane)	14.3sec	
Control Delay (Worst Movement)	13.9sec	13.9sec
Geometric Delay (Average)	4.9sec	
Stop-Line Delay (Average)	0.1sec	
Level of Service (Aver. Int. Delay)	LOS A	
Level of Service (Worst Movement)	LOS A	
Level of Service (Worst Lane)	LOS A	
95% Back of Queue - Vehicles (Worst Lane)	0.2veh	
95% Back of Queue - Distance (Worst Lane)	1.1m	
Total Effective Stops	565veh/h	678pers/h
Effective Stop Rate	0.42per veh	0.42per pers
Proportion Queued	0.02	0.02
Performance Index	18.8	18.8
Travel Distance (Total)	819.4veh-km/h	983.2pers-km/h
Travel Distance (Average)	613m	613m
Travel Time (Total)	15.5veh-h/h	18.6pers-h/h
Travel Time (Average)	41.7sec	41.7sec
Travel Speed	52.9km/h	52.9km/h
Cost (Total)	526.88\$/h	526.88\$/h
Fuel Consumption (Total)	92.1L/h	
Carbon Dioxide (Total)	230.9kg/h	
Hydrocarbons (Total)	0.330kg/h	
Carbon Monoxide (Total)	15.34kg/h	
NOx (Total)	0.523kg/h	

LOS (Aver. Int. Delay) for Vehicles is based on average delay for all vehicle movements. LOS Method: Delay (RTA NSW).

LOS Method for individual vehicle movements and lanes: Delay (RTA NSW).

Roundabout Capacity Model: SIDRA Standard.

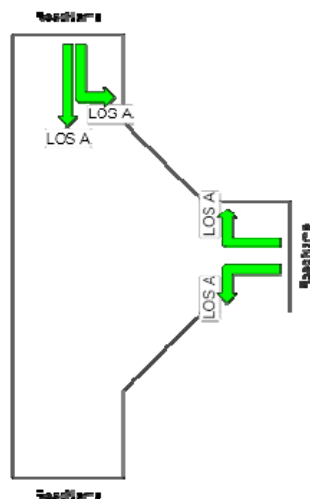

# INTERSECTION SUMMARY

Site: 2833-F6 Off Ramp/Haywards

Intersection Performance - Hourly Values		
Performance Measure	Vehicles	Persons
Demand Flows (Total)	1391 veh/h	1669 pers/h
Percent Heavy Vehicles	7.0%	
Degree of Saturation	0.223	
Practical Spare Capacity	281.3%	
Effective Intersection Capacity	6237 veh/h	
Control Delay (Total)	2.75 veh-h/h	3.29 pers-h/h
Control Delay (Average)	7.1 sec	7.1 sec
Control Delay (Worst Lane)	13.1 sec	
Control Delay (Worst Movement)	13.1 sec	13.1 sec
Geometric Delay (Average)	6.4 sec	
Stop-Line Delay (Average)	0.7 sec	
Level of Service (Aver. Int. Delay)	LOS A	
Level of Service (Worst Movement)	LOS A	
Level of Service (Worst Lane)	LOS A	
95% Back of Queue - Vehicles (Worst Lane)	1.1 veh	
95% Back of Queue - Distance (Worst Lane)	8.0m	
Total Effective Stops	766 veh/h	919 pers/h
Effective Stop Rate	0.55 per veh	0.55 per pers
Proportion Queued	0.21	0.21
Performance Index	22.5	22.5
Travel Distance (Total)	865.3 veh-km/h	1038.4 pers-km/h
Travel Distance (Average)	622m	622m
Travel Time (Total)	17.3 veh-h/h	20.8 pers-h/h
Travel Time (Average)	44.8 sec	44.8 sec
Travel Speed	50.0 km/h	50.0 km/h
Cost (Total)	590.23 \$/h	590.23 \$/h
Fuel Consumption (Total)	103.6 L/h	
Carbon Dioxide (Total)	259.7 kg/h	
Hydrocarbons (Total)	0.384 kg/h	
Carbon Monoxide (Total)	18.67 kg/h	
NOx (Total)	0.607 kg/h	

LOS (Aver. Int. Delay) for Vehicles is based on average delay for all vehicle movements. LOS Method: Delay (RTA NSW).

LOS Method for individual vehicle movements and lanes: Delay (RTA NSW).

Roundabout Capacity Model: SIDRA Standard.

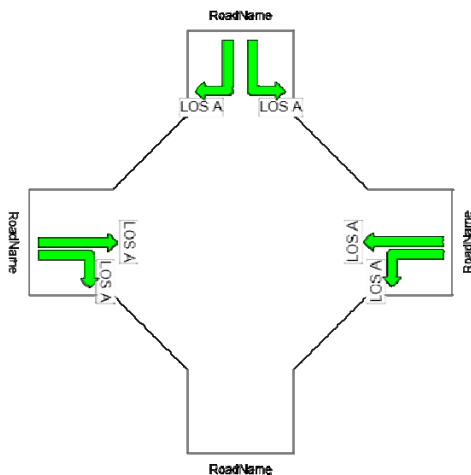

# INTERSECTION SUMMARY

Site: 2813-Haywards/Yallah Rd

Intersection Performance - Hourly Values		
Performance Measure	Vehicles	Persons
Demand Flows (Total)	1346veh/h	1616pers/h
Percent Heavy Vehicles	7.0%	
Degree of Saturation	0.410	
Practical Spare Capacity	107.2%	
Effective Intersection Capacity	3282veh/h	
Control Delay (Total)	3.97veh-h/h	4.76pers-h/h
Control Delay (Average)	10.6sec	10.6sec
Control Delay (Worst Lane)	13.2sec	
Control Delay (Worst Movement)	13.2sec	13.2sec
Geometric Delay (Average)	9.2sec	
Stop-Line Delay (Average)	1.4sec	
Level of Service (Aver. Int. Delay)	LOS A	
Level of Service (Worst Movement)	LOS A	
Level of Service (Worst Lane)	LOS A	
95% Back of Queue - Vehicles (Worst Lane)	2.9veh	
95% Back of Queue - Distance (Worst Lane)	21.4m	
Total Effective Stops	925veh/h	1110pers/h
Effective Stop Rate	0.69per veh	0.69per pers
Proportion Queued	0.38	0.38
Performance Index	25.9	25.9
Travel Distance (Total)	863.9veh-km/h	1036.7pers-km/h
Travel Distance (Average)	642m	642m
Travel Time (Total)	18.6veh-h/h	22.3pers-h/h
Travel Time (Average)	49.7sec	49.7sec
Travel Speed	46.5km/h	46.5km/h
Cost (Total)	631.71\$/h	631.71\$/h
Fuel Consumption (Total)	110.4L/h	
Carbon Dioxide (Total)	276.7kg/h	
Hydrocarbons (Total)	0.424kg/h	
Carbon Monoxide (Total)	21.37kg/h	
NOx (Total)	0.663kg/h	

LOS (Aver. Int. Delay) for Vehicles is based on average delay for all vehicle movements. LOS Method: Delay (RTA NSW).

LOS Method for individual vehicle movements and lanes: Delay (RTA NSW).

Roundabout Capacity Model: SIDRA Standard.

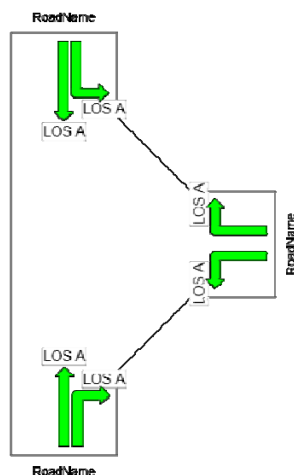

# INTERSECTION SUMMARY

Site: 2138-Main Entrance/Main N/S

Intersection Performance - Hourly Values		
Performance Measure	Vehicles	Persons
Demand Flows (Total)	1063 veh/h	1276 pers/h
Percent Heavy Vehicles	7.0%	
Degree of Saturation	0.328	
Practical Spare Capacity	159.0%	
Effective Intersection Capacity	3239 veh/h	
Control Delay (Total)	2.26 veh-h/h	2.72 pers-h/h
Control Delay (Average)	7.7 sec	7.7 sec
Control Delay (Worst Lane)	9.1 sec	
Control Delay (Worst Movement)	12.4 sec	12.4 sec
Geometric Delay (Average)	5.9 sec	
Stop-Line Delay (Average)	1.7 sec	
Level of Service (Aver. Int. Delay)	LOS A	
Level of Service (Worst Movement)	LOS A	
Level of Service (Worst Lane)	LOS A	
95% Back of Queue - Vehicles (Worst Lane)	2.5 veh	
95% Back of Queue - Distance (Worst Lane)	18.9m	
Total Effective Stops	660 veh/h	792 pers/h
Effective Stop Rate	0.62 per veh	0.62 per pers
Proportion Queued	0.49	0.49
Performance Index	20.9	20.9
Travel Distance (Total)	625.0 veh-km/h	750.0 pers-km/h
Travel Distance (Average)	588m	588m
Travel Time (Total)	15.0 veh-h/h	17.9 pers-h/h
Travel Time (Average)	50.6 sec	50.6 sec
Travel Speed	41.8 km/h	41.8 km/h
Cost (Total)	436.11 \$/h	436.11 \$/h
Fuel Consumption (Total)	73.0 L/h	
Carbon Dioxide (Total)	183.0 kg/h	
Hydrocarbons (Total)	0.277 kg/h	
Carbon Monoxide (Total)	12.67 kg/h	
NOx (Total)	0.389 kg/h	

LOS (Aver. Int. Delay) for Vehicles is based on average delay for all vehicle movements. LOS Method: Delay (RTA NSW).

LOS Method for individual vehicle movements and lanes: Delay (RTA NSW).

Roundabout Capacity Model: SIDRA Standard.

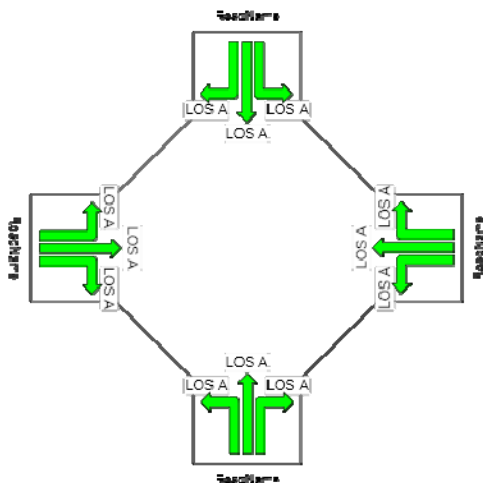

# INTERSECTION SUMMARY

Site: 2135- Main Entrance/Duck Creek

Intersection Performance - Hourly Values		
Performance Measure	Vehicles	Persons
Demand Flows (Total)	800veh/h	960pers/h
Percent Heavy Vehicles	7.0%	
Degree of Saturation	0.338	
Practical Spare Capacity	151.5%	
Effective Intersection Capacity	2367veh/h	
Control Delay (Total)	1.60veh-h/h	1.92pers-h/h
Control Delay (Average)	7.2sec	7.2sec
Control Delay (Worst Lane)	9.9sec	
Control Delay (Worst Movement)	11.3sec	11.3sec
Geometric Delay (Average)	6.5sec	
Stop-Line Delay (Average)	0.7sec	
Level of Service (Aver. Int. Delay)	LOS A	
Level of Service (Worst Movement)	LOS A	
Level of Service (Worst Lane)	LOS A	
95% Back of Queue - Vehicles (Worst Lane)	2.8veh	
95% Back of Queue - Distance (Worst Lane)	20.8m	
Total Effective Stops	452veh/h	542pers/h
Effective Stop Rate	0.56per veh	0.56per pers
Proportion Queued	0.28	0.28
Performance Index	15.1	15.1
Travel Distance (Total)	472.5veh-km/h	567.0pers-km/h
Travel Distance (Average)	591m	591m
Travel Time (Total)	11.2veh-h/h	13.4pers-h/h
Travel Time (Average)	50.3sec	50.3sec
Travel Speed	42.3km/h	42.3km/h
Cost (Total)	324.91\$/h	324.91\$/h
Fuel Consumption (Total)	54.2L/h	
Carbon Dioxide (Total)	136.0kg/h	
Hydrocarbons (Total)	0.205kg/h	
Carbon Monoxide (Total)	9.26kg/h	
NOx (Total)	0.286kg/h	

LOS (Aver. Int. Delay) for Vehicles is based on average delay for all vehicle movements. LOS Method: Delay (RTA NSW).

LOS Method for individual vehicle movements and lanes: Delay (RTA NSW).

Roundabout Capacity Model: SIDRA Standard.

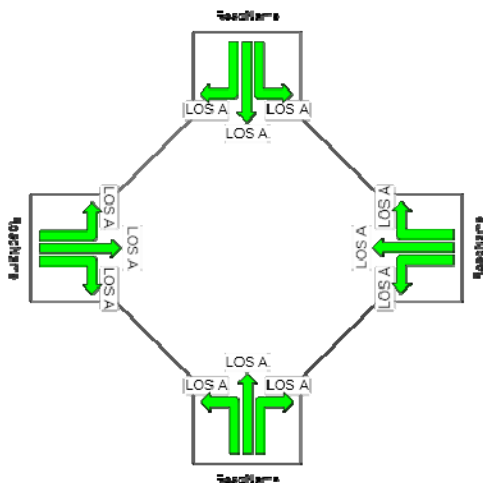

# INTERSECTION SUMMARY

Site: 2181-South Entrance/Main N/S

Intersection Performance - Hourly Values		
Performance Measure	Vehicles	Persons
Demand Flows (Total)	594 veh/h	712 pers/h
Percent Heavy Vehicles	7.0%	
Degree of Saturation	0.238	
Practical Spare Capacity	223.0%	
Effective Intersection Capacity	2256 veh/h	
Control Delay (Total)	0.73 veh-h/h	0.87 pers-h/h
Control Delay (Average)	4.4 sec	4.4 sec
Control Delay (Worst Lane)	9.5 sec	
Control Delay (Worst Movement)	10.6 sec	10.6 sec
Geometric Delay (Average)	4.1 sec	
Stop-Line Delay (Average)	0.3 sec	
Level of Service (Aver. Int. Delay)	LOS A	
Level of Service (Worst Movement)	LOS A	
Level of Service (Worst Lane)	LOS A	
95% Back of Queue - Vehicles (Worst Lane)	1.7 veh	
95% Back of Queue - Distance (Worst Lane)	12.8m	
Total Effective Stops	242 veh/h	291 pers/h
Effective Stop Rate	0.41 per veh	0.41 per pers
Proportion Queued	0.17	0.17
Performance Index	9.9	9.9
Travel Distance (Total)	344.2 veh-km/h	413.0 pers-km/h
Travel Distance (Average)	580m	580m
Travel Time (Total)	7.7 veh-h/h	9.2 pers-h/h
Travel Time (Average)	46.7 sec	46.7 sec
Travel Speed	44.7 km/h	44.7 km/h
Cost (Total)	223.08\$/h	223.08\$/h
Fuel Consumption (Total)	37.0 L/h	
Carbon Dioxide (Total)	92.7 kg/h	
Hydrocarbons (Total)	0.135 kg/h	
Carbon Monoxide (Total)	5.80 kg/h	
NOx (Total)	0.187 kg/h	

LOS (Aver. Int. Delay) for Vehicles is based on average delay for all vehicle movements. LOS Method: Delay (RTA NSW).

LOS Method for individual vehicle movements and lanes: Delay (RTA NSW).

Roundabout Capacity Model: SIDRA Standard.

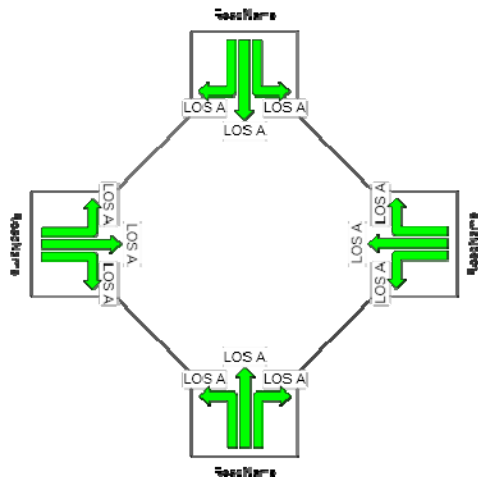

6. 2036 Highway/Internal Intersections with Tallawarra–With Haywards Link-PMP  
**INTERSECTION SUMMARY**

Site: 2557- F6 Off Ramp/Princes

Intersection Performance - Hourly Values		
Performance Measure	Vehicles	Persons
Demand Flows (Total)	3015veh/h	3618pers/h
Percent Heavy Vehicles	7.0%	
Degree of Saturation	0.810	
Practical Spare Capacity	5.0%	
Effective Intersection Capacity	3725veh/h	
Control Delay (Total)	7.06veh-h/h	8.48pers-h/h
Control Delay (Average)	8.4sec	8.4sec
Control Delay (Worst Lane)	13.4sec	
Control Delay (Worst Movement)	13.4sec	13.4sec
Geometric Delay (Average)	5.7sec	
Stop-Line Delay (Average)	2.7sec	
Level of Service (Aver. Int. Delay)	LOS A	
Level of Service (Worst Movement)	LOS A	
Level of Service (Worst Lane)	LOS A	
95% Back of Queue - Vehicles (Worst Lane)	11.2veh	
95% Back of Queue - Distance (Worst Lane)	83.3m	
Total Effective Stops	2080veh/h	2496pers/h
Effective Stop Rate	0.69per veh	0.69per pers
Proportion Queued	0.59	0.59
Performance Index	57.8	57.8
Travel Distance (Total)	1856.0veh-km/h	2227.2pers-km/h
Travel Distance (Average)	616m	616m
Travel Time (Total)	38.6veh-h/h	46.4pers-h/h
Travel Time (Average)	46.1sec	46.1sec
Travel Speed	48.0km/h	48.0km/h
Cost (Total)	1330.07\$/h	1330.07\$/h
Fuel Consumption (Total)	237.3L/h	
Carbon Dioxide (Total)	594.8kg/h	
Hydrocarbons (Total)	0.904kg/h	
Carbon Monoxide (Total)	45.89kg/h	
NOx (Total)	1.444kg/h	

LOS (Aver. Int. Delay) for Vehicles is based on average delay for all vehicle movements. LOS Method: Delay (RTA NSW).

LOS Method for individual vehicle movements and lanes: Delay (RTA NSW).

Roundabout Capacity Model: SIDRA Standard.

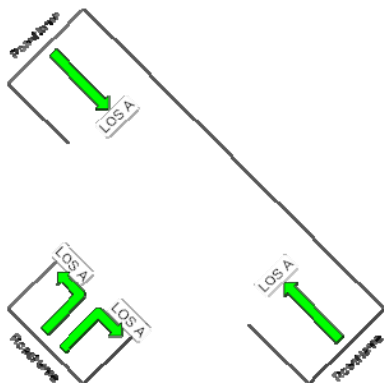

# INTERSECTION SUMMARY

Site: 2469-Princes/Cormack

Intersection Performance - Hourly Values		
Performance Measure	Vehicles	Persons
Demand Flows (Total)	2359veh/h	2831pers/h
Percent Heavy Vehicles	7.0%	
Degree of Saturation	0.506	
Practical Spare Capacity	67.9%	
Effective Intersection Capacity	4660veh/h	
Control Delay (Total)	3.92veh-h/h	4.71pers-h/h
Control Delay (Average)	6.0sec	6.0sec
Control Delay (Worst Lane)	16.2sec	
Control Delay (Worst Movement)	16.2sec	16.2sec
Geometric Delay (Average)	5.1sec	
Stop-Line Delay (Average)	0.9sec	
Level of Service (Aver. Int. Delay)	LOS A	
Level of Service (Worst Movement)	LOS B	
Level of Service (Worst Lane)	LOS B	
95% Back of Queue - Vehicles (Worst Lane)	4.3veh	
95% Back of Queue - Distance (Worst Lane)	31.7m	
Total Effective Stops	1167veh/h	1400pers/h
Effective Stop Rate	0.49per veh	0.49per pers
Proportion Queued	0.21	0.21
Performance Index	38.7	38.7
Travel Distance (Total)	1442.8veh-km/h	1731.4pers-km/h
Travel Distance (Average)	612m	612m
Travel Time (Total)	28.2veh-h/h	33.8pers-h/h
Travel Time (Average)	43.0sec	43.0sec
Travel Speed	51.3km/h	51.3km/h
Cost (Total)	963.24\$/h	963.24\$/h
Fuel Consumption (Total)	170.0L/h	
Carbon Dioxide (Total)	426.2kg/h	
Hydrocarbons (Total)	0.624kg/h	
Carbon Monoxide (Total)	30.05kg/h	
NOx (Total)	0.992kg/h	

LOS (Aver. Int. Delay) for Vehicles is based on average delay for all vehicle movements. LOS Method: Delay (RTA NSW).

LOS Method for individual vehicle movements and lanes: Delay (RTA NSW).

Roundabout Capacity Model: SIDRA Standard.

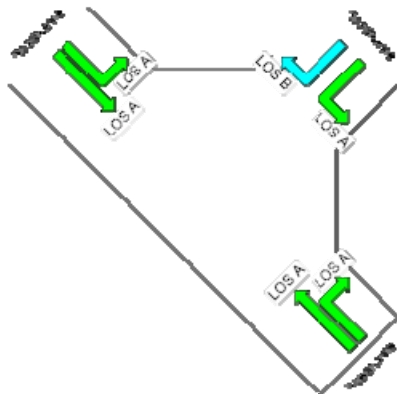

# INTERSECTION SUMMARY

Site: 2467-Princes/Main Entrance

Intersection Performance - Hourly Values		
Performance Measure	Vehicles	Persons
Demand Flows (Total)	2038veh/h	2445pers/h
Percent Heavy Vehicles	7.0%	
Degree of Saturation	0.511	
Practical Spare Capacity	66.2%	
Effective Intersection Capacity	3984veh/h	
Control Delay (Total)	3.54veh-h/h	4.25pers-h/h
Control Delay (Average)	6.3sec	6.3sec
Control Delay (Worst Lane)	16.2sec	
Control Delay (Worst Movement)	15.6sec	15.6sec
Geometric Delay (Average)	5.5sec	
Stop-Line Delay (Average)	0.7sec	
Level of Service (Aver. Int. Delay)	LOS A	
Level of Service (Worst Movement)	LOS B	
Level of Service (Worst Lane)	LOS B	
95% Back of Queue - Vehicles (Worst Lane)	1.2veh	
95% Back of Queue - Distance (Worst Lane)	8.6m	
Total Effective Stops	993veh/h	1192pers/h
Effective Stop Rate	0.49per veh	0.49per pers
Proportion Queued	0.11	0.11
Performance Index	30.7	30.7
Travel Distance (Total)	1257.9veh-km/h	1509.5pers-km/h
Travel Distance (Average)	617m	617m
Travel Time (Total)	24.4veh-h/h	29.3pers-h/h
Travel Time (Average)	43.2sec	43.2sec
Travel Speed	51.5km/h	51.5km/h
Cost (Total)	830.99\$/h	830.99\$/h
Fuel Consumption (Total)	145.0L/h	
Carbon Dioxide (Total)	363.6kg/h	
Hydrocarbons (Total)	0.528kg/h	
Carbon Monoxide (Total)	24.89kg/h	
NOx (Total)	0.832kg/h	

LOS (Aver. Int. Delay) for Vehicles is based on average delay for all vehicle movements. LOS Method: Delay (RTA NSW).

LOS Method for individual vehicle movements and lanes: Delay (RTA NSW).

Roundabout Capacity Model: SIDRA Standard.

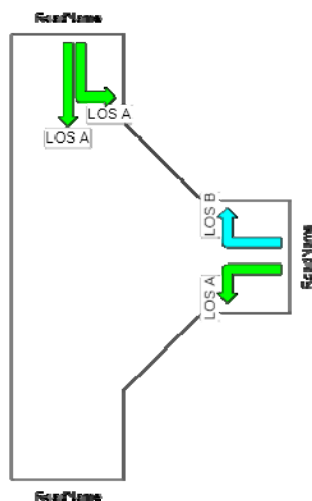

# INTERSECTION SUMMARY

Site: 4358-Princes/South Entrance

Intersection Performance - Hourly Values		
Performance Measure	Vehicles	Persons
Demand Flows (Total)	1732 veh/h	2078 pers/h
Percent Heavy Vehicles	7.0%	
Degree of Saturation	0.474	
Practical Spare Capacity	61.5%	
Effective Intersection Capacity	3290 veh/h	
Control Delay (Total)	2.39 veh-h/h	2.87 pers-h/h
Control Delay (Average)	5.0 sec	5.0 sec
Control Delay (Worst Lane)	15.8 sec	
Control Delay (Worst Movement)	15.8 sec	15.8 sec
Geometric Delay (Average)	4.6 sec	
Stop-Line Delay (Average)	0.4 sec	
Level of Service (Aver. Int. Delay)	LOS A	
Level of Service (Worst Movement)	LOS B	
Level of Service (Worst Lane)	LOS B	
95% Back of Queue - Vehicles (Worst Lane)	1.0 veh	
95% Back of Queue - Distance (Worst Lane)	7.4 m	
Total Effective Stops	754 veh/h	905 pers/h
Effective Stop Rate	0.44 per veh	0.44 per pers
Proportion Queued	0.06	0.06
Performance Index	24.6	24.6
Travel Distance (Total)	1058.9 veh-km/h	1270.6 pers-km/h
Travel Distance (Average)	611 m	611 m
Travel Time (Total)	20.0 veh-h/h	24.0 pers-h/h
Travel Time (Average)	41.5 sec	41.5 sec
Travel Speed	53.0 km/h	53.0 km/h
Cost (Total)	680.24 \$/h	680.24 \$/h
Fuel Consumption (Total)	119.0 L/h	
Carbon Dioxide (Total)	298.4 kg/h	
Hydrocarbons (Total)	0.426 kg/h	
Carbon Monoxide (Total)	19.79 kg/h	
NOx (Total)	0.676 kg/h	

LOS (Aver. Int. Delay) for Vehicles is based on average delay for all vehicle movements. LOS Method: Delay (RTA NSW).

LOS Method for individual vehicle movements and lanes: Delay (RTA NSW).

Roundabout Capacity Model: SIDRA Standard.

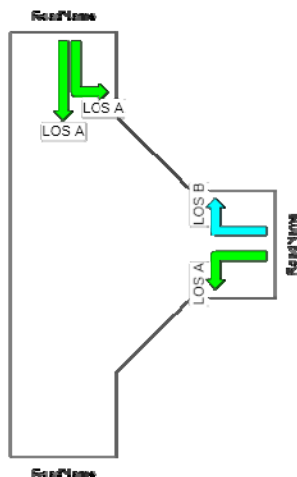

# INTERSECTION SUMMARY

Site: 2833-F6 Off Ramp/Haywards

Intersection Performance - Hourly Values		
Performance Measure	Vehicles	Persons
Demand Flows (Total)	1425veh/h	1710pers/h
Percent Heavy Vehicles	7.0%	
Degree of Saturation	0.280	
Practical Spare Capacity	204.1%	
Effective Intersection Capacity	5099veh/h	
Control Delay (Total)	3.41veh-h/h	4.10pers-h/h
Control Delay (Average)	8.6sec	8.6sec
Control Delay (Worst Lane)	12.8sec	
Control Delay (Worst Movement)	12.8sec	12.8sec
Geometric Delay (Average)	7.3sec	
Stop-Line Delay (Average)	1.3sec	
Level of Service (Aver. Int. Delay)	LOS A	
Level of Service (Worst Movement)	LOS A	
Level of Service (Worst Lane)	LOS A	
95% Back of Queue - Vehicles (Worst Lane)	1.9veh	
95% Back of Queue - Distance (Worst Lane)	14.5m	
Total Effective Stops	900veh/h	1080pers/h
Effective Stop Rate	0.63per veh	0.63per pers
Proportion Queued	0.33	0.33
Performance Index	25.0	25.0
Travel Distance (Total)	893.8veh-km/h	1072.6pers-km/h
Travel Distance (Average)	627m	627m
Travel Time (Total)	18.5veh-h/h	22.2pers-h/h
Travel Time (Average)	46.7sec	46.7sec
Travel Speed	48.3km/h	48.3km/h
Cost (Total)	631.74\$/h	631.74\$/h
Fuel Consumption (Total)	111.3L/h	
Carbon Dioxide (Total)	278.9kg/h	
Hydrocarbons (Total)	0.421kg/h	
Carbon Monoxide (Total)	20.96kg/h	
NOx (Total)	0.664kg/h	

LOS (Aver. Int. Delay) for Vehicles is based on average delay for all vehicle movements. LOS Method: Delay (RTA NSW).

LOS Method for individual vehicle movements and lanes: Delay (RTA NSW).

Roundabout Capacity Model: SIDRA Standard.

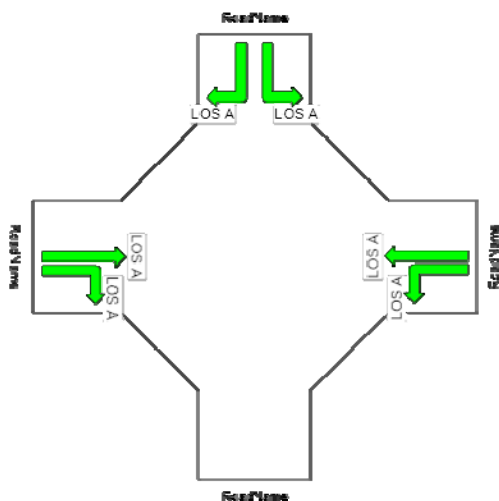

# INTERSECTION SUMMARY

Site: 2813-Haywards/Yallah Rd

Intersection Performance - Hourly Values		
Performance Measure	Vehicles	Persons
Demand Flows (Total)	1148veh/h	1378pers/h
Percent Heavy Vehicles	7.0%	
Degree of Saturation	0.262	
Practical Spare Capacity	224.7%	
Effective Intersection Capacity	4386veh/h	
Control Delay (Total)	3.10veh-h/h	3.72pers-h/h
Control Delay (Average)	9.7sec	9.7sec
Control Delay (Worst Lane)	13.2sec	
Control Delay (Worst Movement)	13.2sec	13.2sec
Geometric Delay (Average)	8.9sec	
Stop-Line Delay (Average)	0.9sec	
Level of Service (Aver. Int. Delay)	LOS A	
Level of Service (Worst Movement)	LOS A	
Level of Service (Worst Lane)	LOS A	
95% Back of Queue - Vehicles (Worst Lane)	1.7veh	
95% Back of Queue - Distance (Worst Lane)	12.8m	
Total Effective Stops	734veh/h	881pers/h
Effective Stop Rate	0.64per veh	0.64per pers
Proportion Queued	0.27	0.27
Performance Index	21.1	21.1
Travel Distance (Total)	733.1veh-km/h	879.7pers-km/h
Travel Distance (Average)	638m	638m
Travel Time (Total)	15.5veh-h/h	18.6pers-h/h
Travel Time (Average)	48.6sec	48.6sec
Travel Speed	47.3km/h	47.3km/h
Cost (Total)	527.38\$/h	527.38\$/h
Fuel Consumption (Total)	92.4L/h	
Carbon Dioxide (Total)	231.7kg/h	
Hydrocarbons (Total)	0.353kg/h	
Carbon Monoxide (Total)	17.69kg/h	
NOx (Total)	0.553kg/h	

LOS (Aver. Int. Delay) for Vehicles is based on average delay for all vehicle movements. LOS Method: Delay (RTA NSW).

LOS Method for individual vehicle movements and lanes: Delay (RTA NSW).

Roundabout Capacity Model: SIDRA Standard.

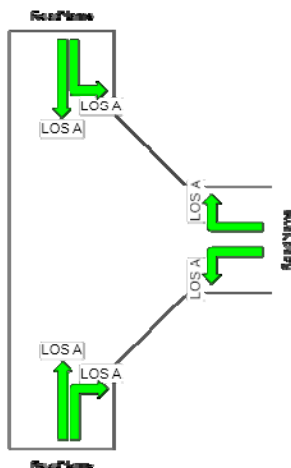

# INTERSECTION SUMMARY

Site: 2138-Main Entrance/Main N/S

Intersection Performance - Hourly Values		
Performance Measure	Vehicles	Persons
Demand Flows (Total)	920veh/h	1104pers/h
Percent Heavy Vehicles	7.0%	
Degree of Saturation	0.366	
Practical Spare Capacity	132.4%	
Effective Intersection Capacity	2515veh/h	
Control Delay (Total)	1.79veh-h/h	2.15pers-h/h
Control Delay (Average)	7.0sec	7.0sec
Control Delay (Worst Lane)	9.3sec	
Control Delay (Worst Movement)	11.4sec	11.4sec
Geometric Delay (Average)	5.5sec	
Stop-Line Delay (Average)	1.5sec	
Level of Service (Aver. Int. Delay)	LOS A	
Level of Service (Worst Movement)	LOS A	
Level of Service (Worst Lane)	LOS A	
95% Back of Queue - Vehicles (Worst Lane)	2.9veh	
95% Back of Queue - Distance (Worst Lane)	21.6m	
Total Effective Stops	539veh/h	647pers/h
Effective Stop Rate	0.59per veh	0.59per pers
Proportion Queued	0.47	0.47
Performance Index	17.6	17.6
Travel Distance (Total)	539.0veh-km/h	646.8pers-km/h
Travel Distance (Average)	586m	586m
Travel Time (Total)	12.8veh-h/h	15.3pers-h/h
Travel Time (Average)	50.0sec	50.0sec
Travel Speed	42.2km/h	42.2km/h
Cost (Total)	372.41\$/h	372.41\$/h
Fuel Consumption (Total)	62.3L/h	
Carbon Dioxide (Total)	156.3kg/h	
Hydrocarbons (Total)	0.235kg/h	
Carbon Monoxide (Total)	10.70kg/h	
NOx (Total)	0.331kg/h	

LOS (Aver. Int. Delay) for Vehicles is based on average delay for all vehicle movements. LOS Method: Delay (RTA NSW).

LOS Method for individual vehicle movements and lanes: Delay (RTA NSW).

Roundabout Capacity Model: SIDRA Standard.

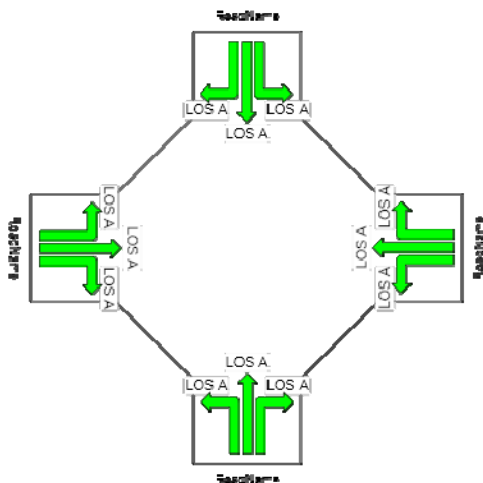

# INTERSECTION SUMMARY

Site: 2135- Main Entrance/Duck Creek

Intersection Performance - Hourly Values		
Performance Measure	Vehicles	Persons
Demand Flows (Total)	640veh/h	768pers/h
Percent Heavy Vehicles	7.0%	
Degree of Saturation	0.230	
Practical Spare Capacity	268.9%	
Effective Intersection Capacity	2778veh/h	
Control Delay (Total)	1.08veh-h/h	1.30pers-h/h
Control Delay (Average)	6.1sec	6.1sec
Control Delay (Worst Lane)	9.1sec	
Control Delay (Worst Movement)	10.0sec	10.0sec
Geometric Delay (Average)	5.4sec	
Stop-Line Delay (Average)	0.7sec	
Level of Service (Aver. Int. Delay)	LOS A	
Level of Service (Worst Movement)	LOS A	
Level of Service (Worst Lane)	LOS A	
95% Back of Queue - Vehicles (Worst Lane)	1.6veh	
95% Back of Queue - Distance (Worst Lane)	12.0m	
Total Effective Stops	330veh/h	397pers/h
Effective Stop Rate	0.52per veh	0.52per pers
Proportion Queued	0.28	0.28
Performance Index	11.5	11.5
Travel Distance (Total)	373.5veh-km/h	448.2pers-km/h
Travel Distance (Average)	584m	584m
Travel Time (Total)	8.7veh-h/h	10.4pers-h/h
Travel Time (Average)	48.8sec	48.8sec
Travel Speed	43.1km/h	43.1km/h
Cost (Total)	252.67\$/h	252.67\$/h
Fuel Consumption (Total)	42.3L/h	
Carbon Dioxide (Total)	106.0kg/h	
Hydrocarbons (Total)	0.158kg/h	
Carbon Monoxide (Total)	7.11kg/h	
NOx (Total)	0.222kg/h	

LOS (Aver. Int. Delay) for Vehicles is based on average delay for all vehicle movements. LOS Method: Delay (RTA NSW).

LOS Method for individual vehicle movements and lanes: Delay (RTA NSW).

Roundabout Capacity Model: SIDRA Standard.

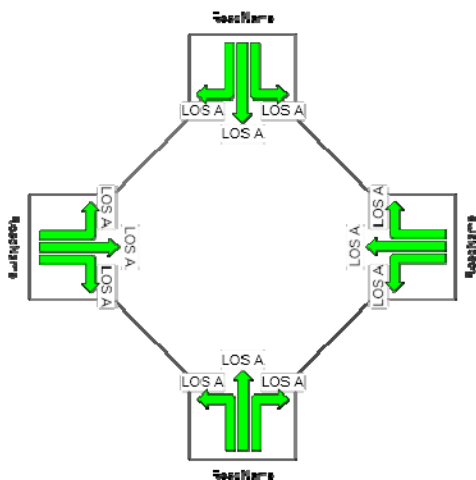

# INTERSECTION SUMMARY

Site: 2181-South Entrance/Main N/S

Intersection Performance - Hourly Values		
Performance Measure	Vehicles	Persons
Demand Flows (Total)	501 veh/h	601 pers/h
Percent Heavy Vehicles	7.0%	
Degree of Saturation	0.171	
Practical Spare Capacity	384.5%	
Effective Intersection Capacity	2856 veh/h	
Control Delay (Total)	0.58 veh-h/h	0.69 pers-h/h
Control Delay (Average)	4.1 sec	4.1 sec
Control Delay (Worst Lane)	8.3 sec	
Control Delay (Worst Movement)	9.8 sec	9.8 sec
Geometric Delay (Average)	4.1 sec	
Stop-Line Delay (Average)	0.1 sec	
Level of Service (Aver. Int. Delay)	LOS A	
Level of Service (Worst Movement)	LOS A	
Level of Service (Worst Lane)	LOS A	
95% Back of Queue - Vehicles (Worst Lane)	1.1 veh	
95% Back of Queue - Distance (Worst Lane)	8.4 m	
Total Effective Stops	199 veh/h	239 pers/h
Effective Stop Rate	0.40 per veh	0.40 per pers
Proportion Queued	0.08	0.08
Performance Index	8.2	8.2
Travel Distance (Total)	289.3 veh-km/h	347.1 pers-km/h
Travel Distance (Average)	577 m	577 m
Travel Time (Total)	6.4 veh-h/h	7.7 pers-h/h
Travel Time (Average)	46.0 sec	46.0 sec
Travel Speed	45.2 km/h	45.2 km/h
Cost (Total)	185.64 \$/h	185.64 \$/h
Fuel Consumption (Total)	30.8 L/h	
Carbon Dioxide (Total)	77.3 kg/h	
Hydrocarbons (Total)	0.112 kg/h	
Carbon Monoxide (Total)	4.80 kg/h	
NOx (Total)	0.156 kg/h	

LOS (Aver. Int. Delay) for Vehicles is based on average delay for all vehicle movements. LOS Method: Delay (RTA NSW).

LOS Method for individual vehicle movements and lanes: Delay (RTA NSW).

Roundabout Capacity Model: SIDRA Standard.

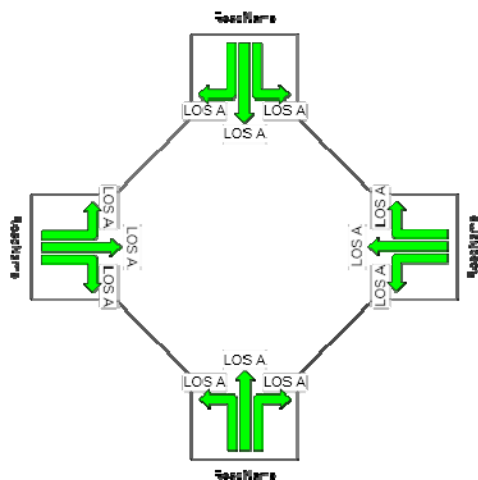

# TALLAWARRA TRAFFIC MODELLING PEER REVIEW REPORT



FOR

TRUENERGY

**BITZIOS**  
consulting

**Gold Coast**  
Suite 26, 58 Riverwalk Avenue  
Robina QLD 4226  
P: (07) 5562 5377  
W: [www.bitziosconsulting.com.au](http://www.bitziosconsulting.com.au)

**Brisbane**  
Level 2, 428 Upper Edward Street  
Spring Hill QLD 4000  
P: (07) 3831 4442  
E: [admin@bitziosconsulting.com.au](mailto:admin@bitziosconsulting.com.au)

**Sydney**  
Studio 203, 3 Gladstone Street  
Newtown NSW 2042  
P: (02) 9557 6202

Project No: P0926

Version No: 001

Issue date: 19 December 2011

## DOCUMENT CONTROL SHEET

### Issue History

Report File Name	Prepared by	Reviewed by	Issued by	Date	Issued to
P0926.001R Tallawarra Traffic Modelling – Peer Review Report	A.Bitzi0s	D.Bitzi0s	A.Bitzi0s	19/12/11	Anthony Savenkov (TRUenergy)



*Copyright in the information and data in this document is the property of Bitzios Consulting. This document and its information and data is for the use of the authorised recipient and this document may not be used, copied or reproduced in whole or in part for any purpose other than for which it was supplied by Bitzios Consulting. Bitzios Consulting makes no representation, undertakes no duty and accepts no responsibility to any third party who may use or rely upon this document or its information and data.*

# CONTENTS

	Page
<b>1. EXECUTIVE SUMMARY.....</b>	<b>1</b>
<b>2. INTRODUCTION .....</b>	<b>2</b>
2.1 PURPOSE	2
2.2 PROJECT BACKGROUND	2
2.3 SCOPE OF PEER REVIEW	2
<b>3. PEER REVIEW .....</b>	<b>3</b>
3.1 TRIP GENERATION	3
3.2 TRIP DISTRIBUTION	3
3.3 MODEL REVIEW	4
3.3.1 Land Use	4
3.3.2 Infrastructure	7
3.3.3 Option Models Coding	12
3.4 OTHER REPORT MATTERS	12
3.4.1 Project Location	12
3.4.2 Proposed Development	12
3.4.3 Preferred Option Review / Discussion	12
3.4.4 Public Transport	13
3.4.5 Sidra Assessments	13
<b>4. CONCLUSIONS.....</b>	<b>14</b>

## Tables

Table 3.1: Adopted Trip Generation

Table 3.2: Comparison of number of trips – SIC vs Tallawarra

Table 3.3: Yallah Marshall Mount, Haywards Bay and Cormack Avenue Trip Comparisons

Table 3.4: West Dapto Trip Comparisons

## Figures

Figure 3.1: Lane Type Comparison

Figure 3.2: Intersection Treatments (south) Comparison

Figure 3.3: Intersection Treatments (north) Comparison

Figure 3.4: Number of Lanes Comparison

Figure 3.5: Existing Bus Services in the Dapto Area

## Appendices

Appendix A: Tallawarra Lands TIA plus Addendum

## 1. EXECUTIVE SUMMARY

Bitzios Consulting has been commissioned by TRUenergy to undertake a review of the traffic modelling completed by Gabites Porter for the proposed development at Tallawarra, NSW.

The scope of the peer review included a review of:

- trip generation assumptions;
- trip distribution conclusions;
- land use and infrastructure changes in the 2036 base models for consistency with the State Infrastructure Contributions (SIC) modelling - including Calderwood;
- land use and infrastructure changes included in the 2036 models for the options tested;
- additional infrastructure determined to be required as a result of the Tallawarra development; and
- the submitted traffic impact assessment.

There were a total of 18 issues identified in the peer review. None of the issues identified were of a critical nature. The main concerns with the assessment which require review included:

- the methodology/assumptions adopted in calculating the trips generated by the development;
- the forecast trip distribution of approximately 80% towards the south; and
- the likely impacts not quantified around the Hayward's Bay interchange and Illawarra Highway / Princes Highway intersection in the interim years (until the Albion Park Bypass is constructed).

Concerns also exist with the fact that no detailed planning has been undertaken on the Albion Park Bypass which may result in a freeway re-alignment or reconfiguration of proposed interchange configurations identified in the SIC modelling. This increases the complexity of addressing the impacts of the proposed development application and determining suitable infrastructure measures.

Notwithstanding this, it is understood that the SIC process has identified a package of infrastructure works funded through developer contributions to mitigate future development impacts such as Tallawarra. The trip generation predicted based on documented methodologies / assumptions for Tallawarra was considered to be within suitable tolerances and subsequently there is not expected to be any major impacts above and beyond what has already been planned for.

## 2. INTRODUCTION

### 2.1 PURPOSE

The purpose of this report is to provide TRUenergy with an independent review of the traffic modelling report completed by Gabites Porter. The need for the report was raised by both Road and Maritime Services (RMS) and Wollongong City Council (WCC) to include a third party review, as Gabites Porter were also responsible for the completion of the SIC modelling process.

### 2.2 PROJECT BACKGROUND

Gabites Porter prepared a Traffic Impact Assessment (TIA) in February 2011 for a proposed large scale development at Tallawarra. The TIA considered traffic impacts for an approximate 10 year horizon and subsequently was based on the 2021 WOLSH (Wollongong and Shellharbour) TRACKS models.

Both RMS and WCC provided comments on the 2021 modelling which the applicant was requested to address. Since that time, Gabites Porter completed the SIC TRACKS models for RMS. Subsequent discussions with RMS and Council resolved that the proposed development should be based on the SIC models, which included additional development activity in the Calderwood area. It was also agreed that a 10 year design horizon is not appropriate for such a large scale development, and that the 2036 SIC model would be more appropriate.

Gabites Porter has prepared an Addendum to the TIA which has addressed both RMS and WCC concerns using the 2036 SIC models as the basis of the assessment. The TIA and Addendum report as submitted to Bitzios Consulting has been included in Appendix A.

### 2.3 SCOPE OF PEER REVIEW

The scope of the peer review included a review of:

- trip generation by the proposed development;
- trip distribution to / from the proposed development;
- land use and infrastructure changes in the 2036 models for consistency with the SIC modelling (including Calderwood);
- land use and infrastructure changes included in the 2036 models for the options tested;
- additional infrastructure determined to be required as a result of the Tallawarra development; and
- the submitted traffic impact assessment.

### 3. PEER REVIEW

#### 3.1 TRIP GENERATION

Table 3.1 shows the trip generation assumptions adopted in the Addendum report.

**Issue#1:** The trip rates included in the spreadsheet provided by Gabites Porter labelled "Land use for Tallawarra" does not align with the trip rates documented within the original TIA. The addendum report should state and justify the revised trip rates adopted.

**Table 3.1: Adopted Trip Generation**

USE	Residential	Retail	Commercial	Enterprise	Industrial	Power Station	School	Trips
GFA/#	1210	10,200	1,125	45,000	217,728	5,968	50	
Trip Rate	0.8	4.5	1.6	1.0	0.2	1.0	0	
Trips	968	459	18	450	490	60	0	2,445

**Issue#2:** The original and revised trip rates are too low. Tallawarra is not located within close proximity to a rail station or frequently serviced bus corridor. Subsequently, the standard RTA trip rates should apply for all uses. The standard trips rates that should be adopted are as follows:

- Residential – 0.85 trips per dwelling
- Retail – 12 to 16 trips per 100m<sup>2</sup>
- Commercial – 2.0 trips per 100m<sup>2</sup>
- Enterprise (Bulky Goods) – 2.5 trips per 100m<sup>2</sup>
- Industrial – 1.0 trips per 100m<sup>2</sup>

**Issue#3:** There has been a school included in the land use spreadsheet, but there has been no trips attributed to this land use in the calculations. An allocation of 50 trips to/from the school in the peak hour appears to be low.

**Issue#4:** An overall trip reduction of 15-20% has been applied which has assumed that there will be a certain amount of multi-purpose trips. The RTA Guide does allow for this to occur, however it needs to be substantiated. There is not enough evidence in the masterplan alone that would suggest that a significant amount of multi-purpose trips will eventuate. The retail range on offer in Tallawarra has to compete with the likes of Dapto Mall and Stockland Shellharbour where multi-purpose trips are likely to be more prevalent. At this stage, it can only be assumed that there may be some shops included to cater for the local residential catchment, and the remaining portion will be specialist facilities designed to support the industrial lands. The location of Tallawarra is relatively difficult to access, subsequently it is not expected to mirror the retail/enterprise corridor that exists to the south of Warrawong. It could be argued however, that as Tallawarra is difficult to access, the retail/commercial trips will be mostly self contained. In that regard and concession of 20% for the retail / commercial component only would be considered appropriate.

**Issue#5:** Whilst the total number of trips is likely to increase substantially by strictly adhering to the RTA trip rates, they will reduce if the impacts of non-coinciding peaks are considered. Section 2.2.7 of Chapter 11 Parking (Austroads) provides typical weightings for each land use across different peak periods of the day (ie Industrial normally shuts down by 4pm, whilst restaurants and return residential work trips normally occur after 5pm, etc.). It is expected that the total generated AM and PM peak trips will be in the same order of magnitude to what has been determined in the TIA / Addendum report.

#### 3.2 TRIP DISTRIBUTION

**Issue#6:** The original TIA states that approximately 80% of the trips are expected to be attracted / generated from the south. This is not typical for the Illawarra region with trips to the north towards

Wollongong CBD and Sydney being more usual. Furthermore, there is expected to be some relationship between the industrial lands at Unanderra, Kembla Grange and Port Kembla with Tallawarra of which all these lands exist to the north. The determined trip distribution should be reviewed and justified.

It should be noted that access from the north to the site is circuitous with no direct route on higher order roads. Any change to the traffic distribution is expected to have significant impacts on surrounding roads and previous planning. This trip re-distribution may require reconsideration of north facing ramps at Tallawarra interchange.

**Issue #7:** If the trips are generated/attracted from the south, then there is expected to be an immediate impact on the Princes Hwy at Macquarie Rivulet as well as the Illawarra Highway metered roundabout. Whilst the SIC process does not require the developer to fund the Albion Park Bypass (which is appropriate), the traffic report should provide greater emphasis on this issue and the need for RMS to consider bringing part of the project forward (such as signalling the Illawarra Hwy / Princes Hwy intersection as an interim measure, or constructing the bypass from the Illawarra Hwy to the Tallawarra interchange). It should be noted that a compounding matter that also does not appear to be considered in this regard is the fact that the additional development trips, are likely to include a very high proportion of truck movements. These vehicle movements will have a much greater impact on the network capacity at the interchange merge/diverge areas as well as the Illawarra Highway / Princes Highway roundabout. It should be noted that the Illawarra Highway / Princes Highway roundabout is near /at capacity now. The lack of detailed planning for the Albion Park Bypass complicates this matter as it reduces the amount of certainty on the final corridor alignment and interchange configurations.

### 3.3 MODEL REVIEW

#### 3.3.1 Land Use

The trips generated from the Tallawarra zones in the SIC model as compared to the 'without development' (Option1) and 'with development' (Option 2-7) are shown in Table 3.2.

Table 3.2: Comparison of number of trips – SIC vs Tallawarra

Zone	SIC 2036		Option 1		Option 2-7	
	Trips AM	Trips PM	Trips AM	Trips PM	Trips AM	Trips PM
<i>Tallawarra</i>						
416	0	0	0	0	121	149
417	0	0	0	0	121	139
418	0	0	0	0	244	182
419	0	0	0	0	195	220
420	0	0	0	0	224	223
517	210	240	0	0	122	140
518	1406	747	0	0	544	290
519	57	71	0	0	85	98
520	174	200	0	0	60	69
521	52	34	0	0	71	53
522	26	25	0	0	242	181
523	139	160	0	0	226	259
524	17	16	0	0	172	129
<b>TOTAL</b>	<b>2081</b>	<b>1493</b>	<b>0</b>	<b>0</b>	<b>2427</b>	<b>2132</b>

Table 3.2 shows that the Option 1 (without development) has removed all the trips from the Tallawarra zones which is acceptable. The development models (Option 2-7) are slightly greater than what was assumed during the SIC modelling (particularly in the PM peak) and is within reasonable tolerances of the calculated generated trips (2445 trips – minus trip linking concession as discussed in the original TIA).

As the trips generated/attracted by the Tallawarra zone is in a similar order of magnitude to what was completed in the SIC modelling, there is no expectation that a large quantum of additional infrastructure

would be required above and beyond what was included in the SIC modelling. Subsequently, current recommendations to include a small number of roundabout upgrades in the vicinity of Tallawarra are considered to be consistent with the above information.

Table 3.3 provides a comparison between the SIC model and development models for the trips generated/attracted by the Yallah Marshall Mount, Haywards Bay, and Cormack Avenue areas.

**Table 3.3: Yallah Marshall Mount, Haywards Bay and Cormack Avenue Trip Comparisons**

Zone	SIC 2036		Option 1-7	
	Trips AM	Trips PM	Trips AM	Trips PM
<i>Yallah Marshall Mount / Haywards Bay/Cormack</i>				
159	309	363	310	364
160	195	214	196	213
162	396	451	397	451
165	490	551	491	552
176	36	41	36	41
351	360	411	360	411
352	142	153	142	153
353	53	66	54	66
354	3	3	3	3
355	149	86	150	87
359	52	65	53	66
362	33	39	33	39
363	361	407	362	408
<b>TOTAL</b>	<b>2579</b>	<b>2850</b>	<b>2587</b>	<b>2854</b>

Table 3.3 shows a slight increase in trips in the development models from the SIC models, which is consistent with the findings from Table 3.2 (Tallawarra is expected to have a slight increase in trips than what was included in the SIC modelling).

Table 3.4 provides a comparison between the SIC model and development models for the trips generated/attracted by a number of the larger zones in the West Dapto area.

Table 3.4: West Dapto Trip Comparisons

Zone	SIC 2036		Option 1-7	
	Trips AM	Trips PM	Trips AM	Trips PM
<i>West Dapto</i>				
172	749	841	749	842
174	288	324	288	324
175	403	460	403	461
192	352	388	353	389
260	228	187	228	187
337	511	582	513	583
343	425	481	428	483
360	296	337	299	339
361	388	427	389	428
364	334	366	334	366
365	783	858	787	859
366	510	558	510	559
367	598	667	600	667
383	707	806	711	808
384	333	383	336	386
424	462	520	463	521
513	335	374	336	375
514	460	519	461	520
166	671	756	671	756
<b>TOTAL</b>	<b>8833</b>	<b>9834</b>	<b>8859</b>	<b>9853</b>

Table 3.4 shows a slight increase in trips in the development models from the SIC models, which is again consistent with the findings from Table 3.2.

Table 3.5 provides a comparison between the SIC model and development models for the trips generated/attracted by the Calderwood area.

Table 3.5: West Dapto Trip Comparisons

Zone	SIC 2036		Option 1-7	
	Trips AM	Trips PM	Trips AM	Trips PM
<i>Calderwood</i>				
178	54	64	54	64
488	147	161	147	161
525	187	183	187	183
526	275	269	276	270
527	531	521	533	522
528	169	123	170	123
529	343	201	346	202
530	187	182	187	183
531	77	84	77	84
532	275	269	276	270
533	159	196	160	196
534	447	438	448	439
535	361	354	362	355
536	187	182	187	182
537	93	91	93	91
538	389	389	390	389
539	220	216	221	216
540	196	191	197	191
541	285	274	286	274
<b>TOTAL</b>	<b>4582</b>	<b>4388</b>	<b>4597</b>	<b>4395</b>

Table 3.5 shows a slight increase in trips in the development models from the SIC models, which is again consistent with the findings from Table 3.2.

### 3.3.2 Infrastructure

The option coding has been reviewed for consistency with the SIC modelling. Each of the options was also reviewed for accuracy.

Figure 3.1 to Figure 3.4 show comparisons between the SIC models and the development option models. Figure 3.1 shows that the lane types are generally consistent between the SIC model and development models. Two coding differences were identified and are included below.

**Issue#8:** West Dapto Road / Princes Highway / Northcliffe Drive upgrade, including the Reddalls Road deviation has been included in the development models, whilst not included in the SIC models.

**Issue#9:** A connection between the Power Station and Tallawarra Road has been removed in the development models.

Figure 3.2 and Figure 3.3 shows the comparison of intersection treatments between the SIC model and development models. No discrepancies were identified. It should be noted that the development models include single lane links with two approach lanes on the proposed new roundabouts at Tallawarra interchange which is considered acceptable. A number of signalised intersections along the Princes Highway were also checked with no discrepancies found in the intersections reviewed. Figure 3.4 shows the comparison of the number of lanes between the SIC model and development models with the single issue included below.

**Issue#10:** West Dapto Road is shown as a four lane road from Darkes Road to Northcliffe Drive.

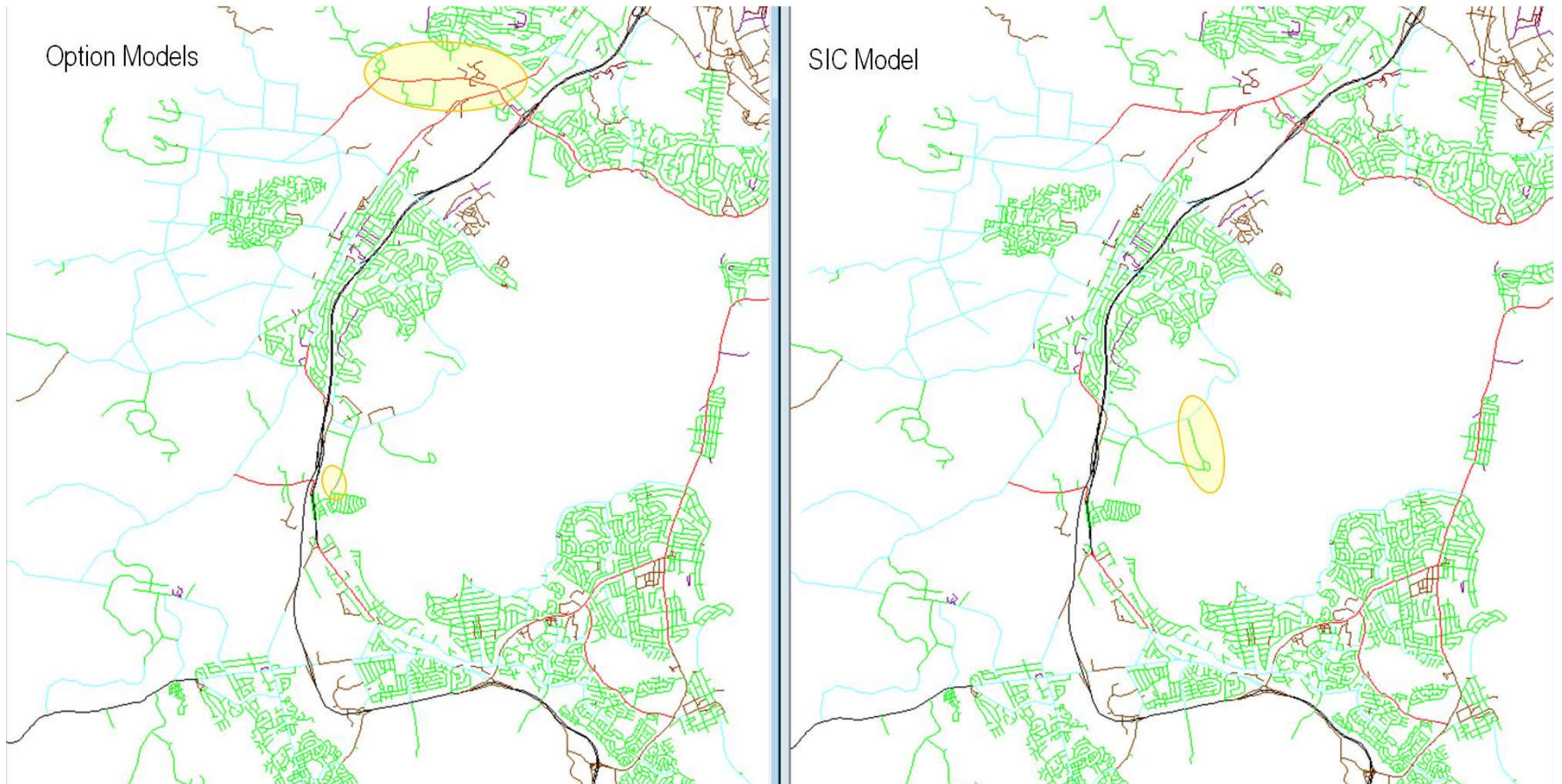

Figure 3.1: Lane Type Comparison

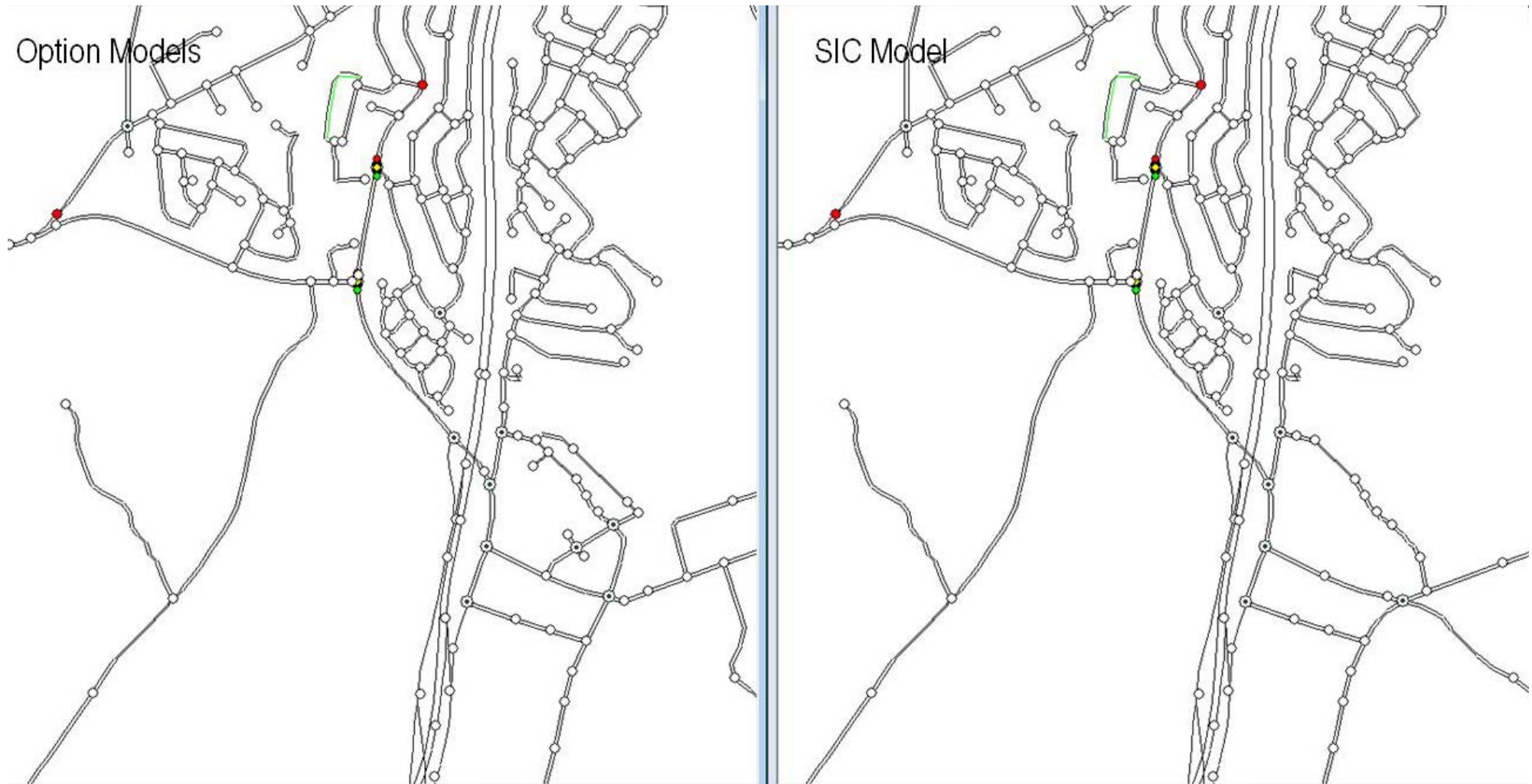

Figure 3.2: Intersection Treatments (south) Comparison

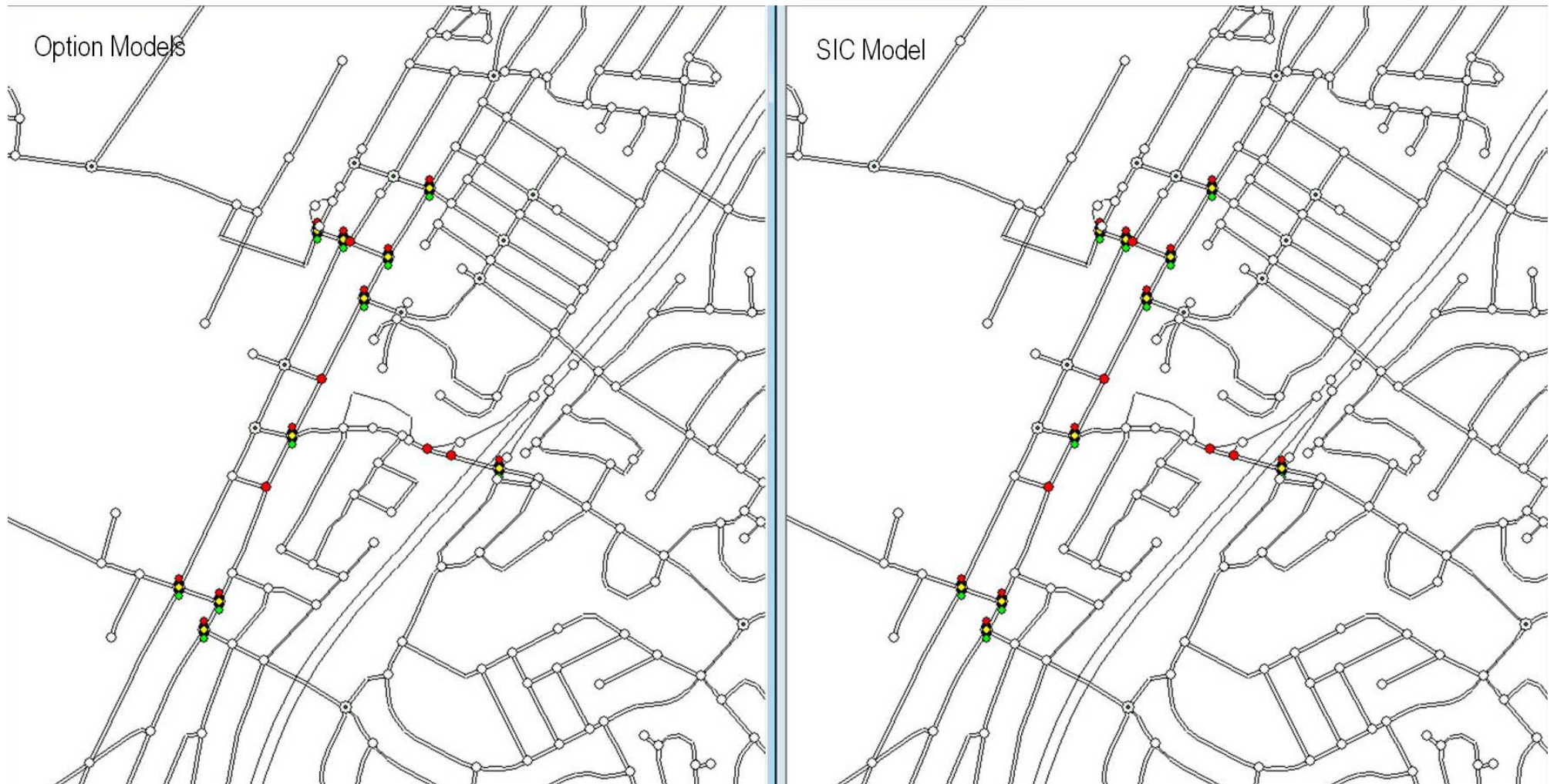

Figure 3.3: Intersection Treatments (north) Comparison

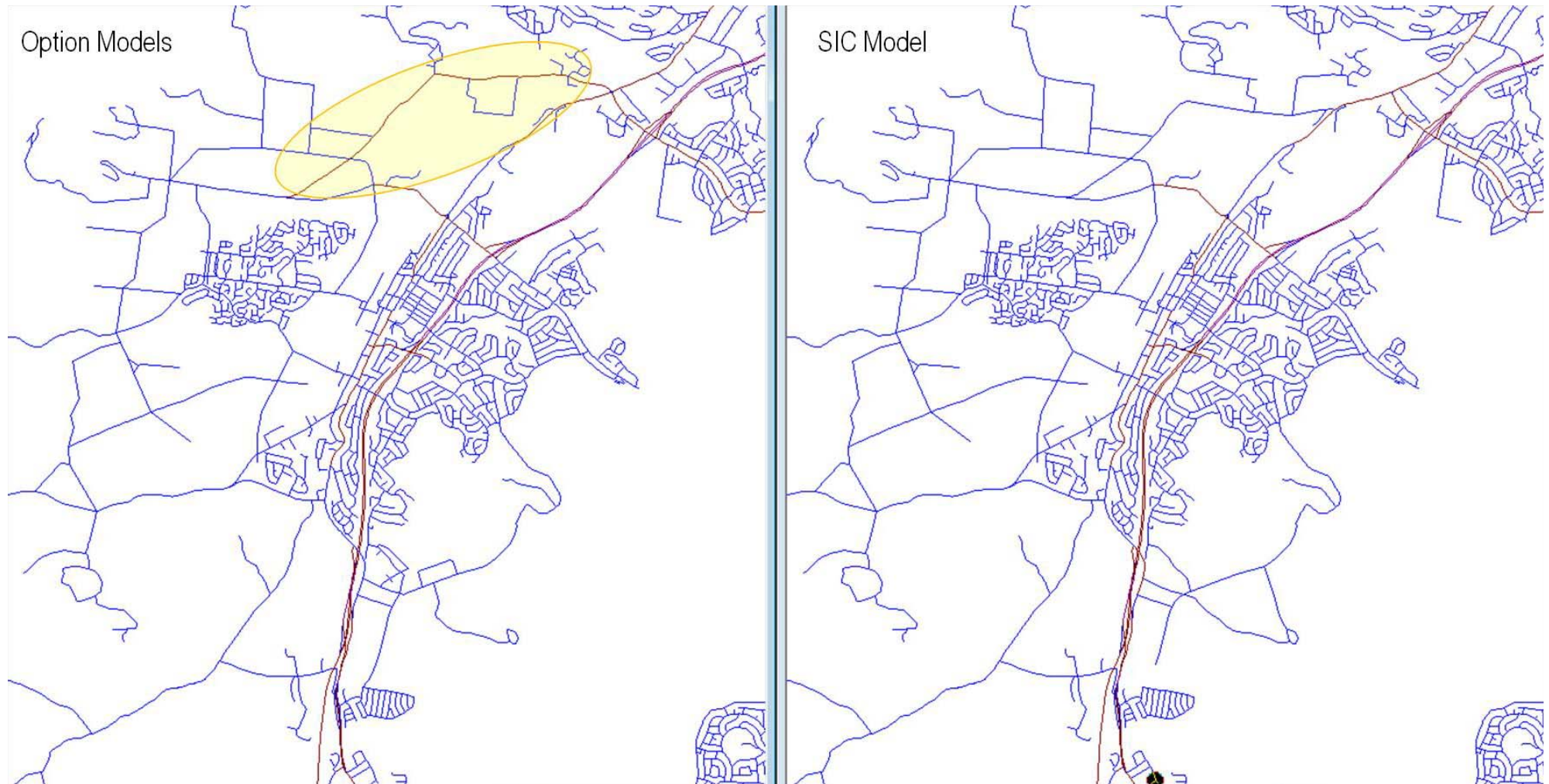

Figure 3.4: Number of Lanes Comparison

### 3.3.3 Option Models Coding

All of the model options were checked for coding compared to the described option. They appeared to be consistent apart from one option as listed below.

**Issue#11:** Option 5 is described as a test of a four lane road, when it is coded as three lanes (two lanes southbound, one lane northbound).

## 3.4 OTHER REPORT MATTERS

### 3.4.1 Project Location

**Issue#12:** There should be a map at the start of the report that clearly shows the locality of the proposed development site at a reasonable scale (ie a map that possibly shows where the site is in relation to Wollongong, Port Kembla, West Dapto, Calderwood, and maybe even Sydney). It may be decided to use a location map that is consistent with other parallel studies.

### 3.4.2 Proposed Development

**Issue#13:** A figure should be shown and / or table included which clearly describes the proposed development in terms of the size (GFA) and location each proposed land use that is being sought after under the planning approval. This is even more paramount given that the proposed land use has changed since the original TIA.

### 3.4.3 Preferred Option Review / Discussion

At this stage a preferred option has not been selected. It is understood that Option 2, Option 6 or Option 7 are preferred, with the latter two options more favourable if they are feasible to construct.

**Issue#14 (for information only):** The assessment thus far has only considered strategic modelling and intersection analysis. It has not considered the performance of the south facing ramps at Haywards Bay. A microsimulation model has been completed for the area which showed congestion resulting from northbound vehicles slowing down in the left hand lane to take the Haywards Bay exit. Increases in traffic movements at this location resulted in flow breakdown on the Princes Highway. Increased traffic volumes on the southbound exit ramp were also noticed to introduce traffic friction, with a 'weave' being introduced from Haywards Bay / Tallawarra traffic wishing to travel towards the Illawarra Highway. Furthermore the spacing between the Haywards Bay and Princes Highway entry ramps / exit ramps is not considered desirable for a freeway environment. The ramp lengths and spacing are not expected to meet current design standards for a freeway/motorway. Ideally, a single interchange with a sufficient service road network would be suitable for this area, whereby Tallawarra can be integrated with other local areas such as Haywards Bay and Kanahooka whilst not encouraging large volumes of traffic through residential streets or local trips on the F6.

Central to this issue is the lack of detailed planning completed by RMS to lock in a detailed alignment and configuration of the Albion Park Bypass for which Tallawarra, Calderwood and Yallah-Marshall Mount can all base their development access upon. The issue of timing of implementation of the bypass and how interim congestion and subsequent safety issues are to be managed are of concern.

Any option taken forward as the preferred option needs to be cognisant of poor location and design of the Hayward's Bay interchange entry and exit ramps. The intersections within the interchange are also of a poor design and increases in traffic volumes at these locations would also reduce the safe operations of these intersections.

**Issue#15:** The preferred option recommends a series of roundabouts along the Princes Highway. It is considered more appropriate that a signalised intersection be provided at the northbound Tallawarra exit ramp. A roundabout gives priority to the westbound movement along the Princes Highway, whereas priority should be given to the exit ramp. Given the large sized vehicles expected to use this route, it may be difficult to fit large diameter roundabouts at each of the other locations as well. Subsequently, it may be

more cost effective to install traffic signals. Further to this, pedestrians and cyclists will generally find it difficult to navigate through higher speed roundabouts as compared to signalised intersections. RMS has previously raised concerns with the need to improve pedestrian/cycle amenity under the F6 at Tallawarra suggesting a possible future pedestrian/cycle corridor along the Princes Highway at this location.

**Issue#16 (for information only):** The preferred option should aim to separate truck movements from vehicle movements where-ever possible. To further support this, the preferred option should try and include as many links into adjacent areas to enable local access between local areas (ie Hayward's Bay / Koonawarra / Kanahooka / East Dapto, etc). As mentioned previously, caution is required in this masterplanning exercise to try and not encourage too much additional traffic at the Hayward's Bay interchange. With the capacity / safety restrictions expected at Hayward's Bay interchange, widening of the Princes Highway under the F6, combined with a well designed local traffic access towards the rear of Hayward's Bay may be an option worth considering.

### 3.4.4 Public Transport

**Issue 17#:** It is unlikely that the proposed bus routes (Figure 30 – TIA) would be feasible as patrons levels would not exceed the critical mass required to make it viable. Re-consideration of the proposed bus route strategy / plan is required unless the services are planned to be heavily subsidised by the developer on an ongoing basis. Figure 3.5 shows the existing bus routes in the area, with Service 43 being the only service that can easily be extended, with consideration maybe given to extending Service 33 via Gilba Road to address the eastern residential area.

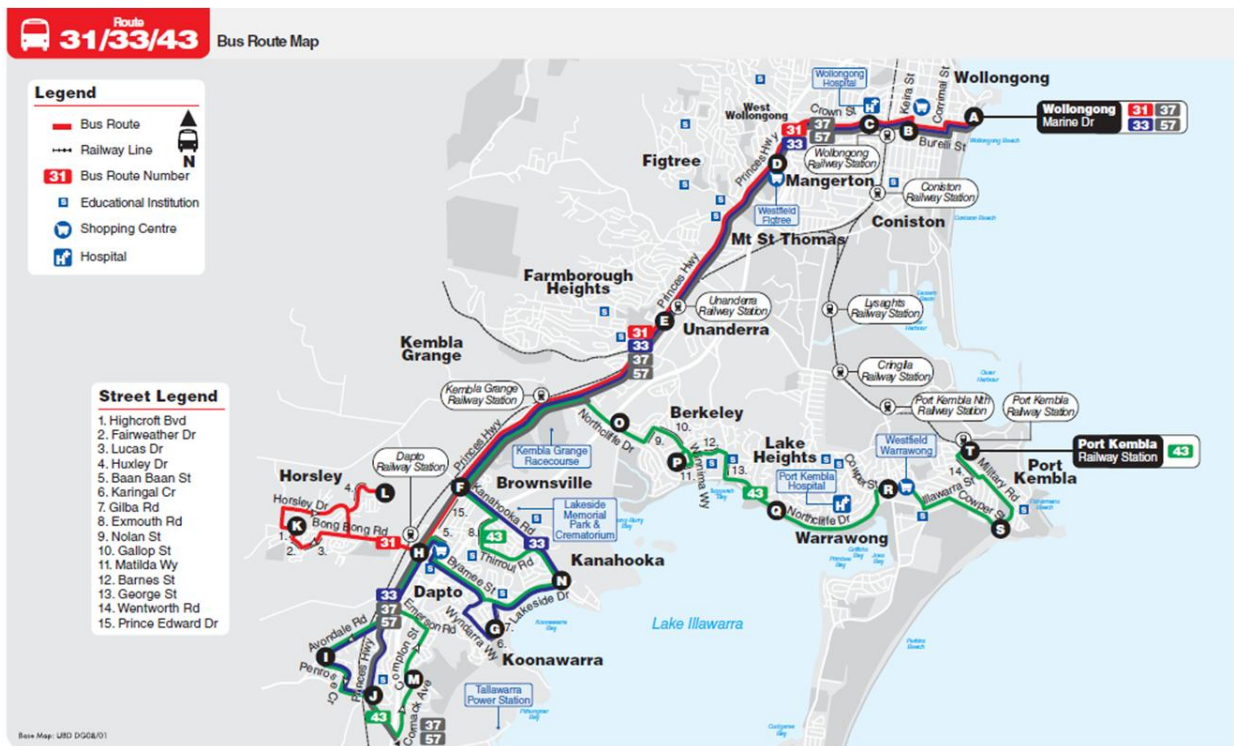

Figure 3.5: Existing Bus Services in the Dapto Area

### 3.4.5 Sidra Assessments

**Issue 18#:** The Sidra assessments do not include road names on the diagrams for each movement summary. The Sidra's were not assessed for technical competence as clarification on trip generation / trip distribution is required prior to Sidra being considered for review. There is some concern with using strategic volume turn counts directly into Sidra without comparisons with existing turn count data (mainly for Haywards Bay interchange sites and the northbound exit ramp intersection to Tallawarra). Also, not sure which exit ramp Intersection Number 5 is referring to (F6 exit ramp / Haywards Bay). The northbound exit ramp intersection is expected to be problematic.

## 4. CONCLUSIONS

Bitzios Consulting has been commissioned by TRUenergy to undertake a review of the traffic modelling completed by Gabites Porter for the proposed development at Tallawarra, NSW.

There were a total of 18 issues identified in the peer review. None of the issues identified were of a critical nature. The main concerns with the assessment which require review included:

- the methodology/assumptions adopted in calculating the trips generated by the development;
- the forecast trip distribution of approximately 80% towards the south; and
- the likely impacts not quantified around the Hayward's Bay interchange and Illawarra Highway / Princes Highway intersection in the interim years (until the Albion Park Bypass is constructed).

Concerns also exist with the fact that no detailed planning has been undertaken on the Albion Park Bypass which may result in a freeway re-alignment or reconfiguration of proposed interchange configurations identified in the SIC modelling. This increases the complexity of addressing the impacts of the proposed development application and determining suitable infrastructure measures.

Notwithstanding this, it is understood that the SIC process has identified a package of infrastructure works funded through developer contributions to mitigate future development impacts such as Tallawarra. The trip generation predicted based on documented methodologies / assumptions for Tallawarra was considered to be within suitable tolerances and subsequently there is not expected to be any major impacts above and beyond what has already been planned for.

## Peer Review Issues Response

As part of the Peer Review process, the Peer Review highlighted a number of Issues worthy of note. Some related to clarification of information in both the original Tallawarra TIA and the Addendum Report and others were "Information Only" relating to issues outside the review process. The Peer Reviewer concluded that none of these issues were of a critical nature and,

"Notwithstanding this, it is understood that the SIC process has identified a package of infrastructure works funded through developer contributions to mitigate future development impacts such as Tallawarra. The trip generation predicted based on documented methodologies / assumptions for Tallawarra was considered to be within suitable tolerances and subsequently there is not expected to be any major impacts above and beyond what has already been planned for."

The issues raised will be commented on in order.

**Issue#1:** The trip rates included in the spreadsheet provided by Gabites Porter labelled "Land use for Tallawarra" does not align with the trip rates documented within the original TIA. The addendum report should state and justify the revised trip rates adopted.

The spreadsheet provided unfortunately had a number of error in the generation calculations. The rates used in the updated spreadsheet are the same as those used in the TIA. The expected trip rates for each of the land use types as well as their explanations are detailed in the original Tallawarra TIA Section 3.2. The rates adopted for the Tallawarra Development were as follows:

- Residential – 0.60 trips per HH based higher than average HH densities
- Retail – 4.6 trips per 100m<sup>2</sup> for mixture of retail uses and an average day
- Commercial – 1.5 trips per 100m<sup>2</sup> for reduced Tallawarra mode split
- Enterprise & Power Station – 1.0 trips per 100m<sup>2</sup>
- Industrial - RTA guide says that 68% of the employees are car drivers and that 55% of the commuter travel occurs in the peak hour. This formula has been used.

Applying the same assumptions as above, the expected Peak trip generation would be 2509 trips compared with 2477 trips generated by the model.

Section 4.2 of the Addendum Report has been updated to reflect the above.

**Issue#2:** The original and revised trip rates are too low.

The generation rates used in both the TIA and the Addendum are considered reasonable for this development. The RTA rates are standard rates and do not necessarily apply in all instances. The reasons for reductions in the standard rates are explained in Section 3.2 of the TIA. It should be noted that the trips generated independently by the WOLSH TRACKS model bear very close agreement with the rates produced by the TIA.

**Issue#3:** There has been a school included in the land use spreadsheet, but there has been no trips attributed to this land use in the calculations. An allocation of 50 trips to/from the school in the peak hour appears to be low.

The exact make up of the primary school is not known at this time. However, to be consistent with the SIC modelling of schools in the West Dapto and Calderwood areas a nominal 50 jobs have been used to represent a primary school. The TRACKS model creates trips to and from the school based on the number of employees. The number of modelled trips specifically to the school is unknown as it is included with other land use in the zone. It is however not 50 trips as indicated in the review.

**Issue#4:** An overall trip reduction of 15-20% has been applied which has assumed that there will be a certain amount of multi-purpose trips.

The reference in the TIA to the 15-20% permitted reduction was simply a comment on how some of the reductions detailed in the TIA are allowed for by the RTA for multi-purpose trips. The reduced rates detailed in the TIA and the Addendum Report already take advantage of these possible reductions. No additional 15-20% reduction to the calculated rates was applied.

**Issue#5:** Whilst the total number of trips is likely to increase substantially by strictly adhering to the RTA trip rates, they will reduce if the impacts of non-coinciding peaks are considered. Section 2.2.7 of Chapter 11 Parking (Austroads) provides typical weightings for each land use across different peak periods of the day (ie Industrial normally shuts down by 4pm, whilst restaurants and return residential work trips normally occur after 5pm, etc.). It is expected that the total generated AM and PM peak trips will be in the same order of magnitude to what has been determined in the TIA / Addendum report.

It is agreed that non-coincident peaks have an impact of peak hour trips. To a large degree this is taken into account directly in the TRACKS model. The AM and PM peak trips in the TRACKS model for the Tallawarra Development are 2477 and 2157 respectively.

**Issue#6:** The original TIA states that approximately 80% of the trips are expected to be attracted /generated from the south. This is not typical for the Illawarra region with trips to the north towards Wollongong CBD and Sydney being more usual.

Gabites Porter is not sure where this percentage comes from. However, Figures 10 and 13 of the TIA show that in 2021 the balance of flow to and from the development is closer to 40%/60% north and south. Section 6.4 of the original TIA indicated the distribution of the 2021 evening peak volumes to and from the Development.

To clarify them there are :

- 300 vph travelling south on the Princes Highway
- 190vph on the freeway exiting at Fowlers Road
- 140vph travel through the residential area of Kanahooka to access the northern outlet
- 90 vph of locally generated traffic
- 180 vph enter the site through Gibbs Road
- 50vph from the freeway at Fowlers Road, and the rest generated locally in Koonawarra.

The TIA expects that 1260 vph will travel to the south and southwest. Therefore the TIA expected that there would be 1260/2160 (58%) heading south and 900/2160 (42%) heading north.

In addition, the 2036 Addendum analysis shows that in the AM peak 994/2477 trips (40%) and in the PM peak 824/2157 (38%) travel to and from the south. Given the change in land use expected between 2021 and 2036 the change in distribution of trips to and from the Development between the original TIA and the Addendum analysis appears reasonable.

**Issue #7:** If the trips are generated/attracted from the south, then there is expected to be an immediate impact on the Princes Hwy at Macquarie Rivulet as well as the Illawarra Highway metered roundabout.

This issue relates to timing of the SIC projects expected to be in operation by 2036. The SIC analysis looked at what infrastructure was required at 5 year intervals based on the development that had occurred in the preceding 5 years. This analysis took into account what the growth in Tallawarra and the surrounding West Dapto and Calderwood developments would have on the Princes Hwy. With each 5 year interval the upgrading of the Princes and Illawarra Highways would occur at a rate commensurate with the demand placed on it by the surrounding developments.

Further, upgrades to the Haywards Bay Interchange were not part of the SIC projects list and were not considered in either the SIC analysis or the TIA. However, Level of Service plots produced for the Addendum Report did not indicate any operational issues with either the interchange's slip roads or intersections as a result of the Tallawarra Development.

**Issue#8:** West Dapto Road / Princes Highway / Northcliffe Drive upgrade, including the Reddalls Road deviation has been included in the development models, whilst not included in the SIC models.

The deviation was included in the 2036 Upgraded SIC models. The Addendum TRACKS analysis was all based on this 2036 Upgraded network as agreed with WCC and RMS.

**Issue#9:** A connection between the Power Station and Tallawarra Road has been removed in the development models.

The Addendum analysis uses the latest internal Tallawarra network as shown in Figure 2 of the Addendum Report. The SIC analysis used a network based on the previous Development design. The removal of the additional internal road from the Heads to Tallawarra Rd is not expected to result in any appreciable change in flows to and from the site.

**Issue#10:** West Dapto Road is shown as a four lane road from Darkes Road to Northcliffe Drive.

As detailed in Issue 8, the four laning of Darkes Rd was included in the 2036 Upgraded SIC models. The Addendum TRACKS analysis was all based on this 2036 Upgraded network as agreed with WCC and RMS.

**Issue#11:** Option 5 is described as a test of a four lane road, when it is coded as three lanes (two lanes southbound, one lane northbound).

This has been corrected in the Addendum Report to read Three Lanes.

**Issue#12:** There should be a map at the start of the report that clearly shows the locality of the proposed development site at a reasonable scale (ie a map that possibly shows where the site is in relation to Wollongong, Port Kembla, West Dapto, Calderwood, and maybe even Sydney).

This has been added as Figure 1 in the Addendum Report.

**Issue#13:** A figure should be shown and / or table included which clearly describes the proposed development in terms of the size (GFA) and location each proposed land use that is being sought after under the planning approval.

A figure showing the latest development design for Tallawarra has been included in the Addendum Report as Figure 2. Details of the expected land use GFA have been included in Section 4.2 of the Addendum Report.

**Issue#14 (for information only):** The assessment thus far has only considered strategic modelling and intersection analysis. It has not considered the performance of the south facing ramps at Haywards Bay.

These ramps were not part of the infrastructure considered in the SIC analysis and were therefore not included in the Addendum analysis.

**Issue#15:** The preferred option recommends a series of roundabouts along the Princes Highway.

The Peer Review indicates that a traffic signal installation at the intersection of the Tallawarra Northbound Off Ramp and Princes Hwy would be preferable to the proposed roundabout. Whilst the use of traffic signals has a number of advantages at this location it was not considered in the short term. The westbound flow along the Princes Hwy through this intersection is not expected to overly high. The operation of the southern ramp approach is not expected to excessively impeded.

If roundabout operation becomes a problem in the future the installation of traffic signals would a logical next step.

**Issue#16 (for information only):** The preferred option should aim to separate truck movements from vehicle movements where-ever possible. To further support this, the preferred option should try and include as many links into adjacent areas to enable local access between local areas (ie Hayward's Bay / Koonawarra / Kanahooka / East Dapto, etc).

Whilst the desire to separate light and heavy vehicle movements as much as possible is understandable, in this instance the WCC has expressed a desire to keep movement to and from the Tallawarra Development away from the Koonawarra and Kanahooka areas. Additional connections to these areas are highly unlikely.

**Issue#17:** It is unlikely that the proposed bus routes (Figure 30 – TIA) would be feasible as patrons levels would not exceed the critical mass required to make it viable.

No Comment

**Issue#18:** The Sidra assessments.

The use of strategic flows directly from the TRACKS model was considered reasonable at this stage of the development analysis as it is of a strategic nature. The 2036 TRACKS model is based on the fully validated 2006 model of the WOLSH area and is expected to reasonably replicate the movements occurring in the area. The F6 exit ramp / Haywards Bay intersection was of greater concern to the RMS as queues back onto the F6 from the intersection could not be allowed.

**Gold Coast Office**  
S: Suite 26, 58 Riverwalk Avenue  
Robina QLD 4226  
M: PO Box 5102 Q Super Centre  
Mermaid Waters QLD 4218  
P: (07) 5562 5377  
F: (07) 5562 5733  
W: www.bitziosconsulting.com.au

**Brisbane Office**  
S: Level 2, 428 Upper Edward Street  
Spring Hill QLD 4000  
M: Level 2, 428 Upper Edward Street  
Spring Hill QLD 4000  
P: (07) 3831 4442  
F: (07) 3831 4455  
E: admin@bitziosconsulting.com.au

**Sydney Office**  
S: Studio 203, 3 Gladstone Street  
Newtown NSW 2042  
M: Studio 203, 3 Gladstone Street  
Newtown NSW 2042  
P: (02) 9557 6202  
F: (02) 9557 6219

Our Reference: P0926.001L

Your Reference:

23 December 2011

Gabites Porter

Attention: **Dave Hunter**

Sent via email: dave.hunter@gabites.co.nz

Dear Dave

**RE : TALLAWARRA PEER REVIEW REPORT**

Further to our peer review report, your peer review response technical note and our subsequent emails dated 21<sup>st</sup> and 22<sup>nd</sup> of December, I am now comfortable with the changes being made to the final addendum report.

It should be noted however that there were two issues that reside with RMS for consideration or final decision, that being:

- Agreement to use of the SIC model with the inclusion of four laning of West Dapto Road and the West Dapto Road / Princes Highway interchange upgrade in the development option models; and
- Consideration to bring forward improvements to the first stages of the Albion Park Bypass to address potential issues with the south facing ramps at Haywards Bay interchange and/or extended peak hour failure of the Illawarra Highway / Princes Highway intersection.

Yours faithfully



**Adrian Bitzios**  
Principal Engineer  
BITZIOS CONSULTING